



User's Guide

Multimedia Projector

EB-L12002Q



EB-L12000Q

Notations Used in This Guide



- **Safety indications**

The documentation and the projector use graphical symbols to show how to use the projector safely.

The indications and their meaning are as follows. Make sure you understand them properly before reading the guide.

 Warning	This symbol indicates information that, if ignored, could possibly result in personal injury or even death due to incorrect handling.
 Caution	This symbol indicates information that, if ignored, could possibly result in personal injury or physical damage due to incorrect handling.

- **General information indications**

Attention	Indicates procedures which may result in damage or injury if sufficient care is not taken.
	Indicates additional information and points which may be useful to know regarding a topic.
	Indicates a page where detailed information regarding a topic can be found.
[Name]	Indicates the name of the buttons on the remote control or the control panel. Example: [Esc] button
Menu Name	Indicates Configuration menu items. Example: Select Brightness from Image . Image - Brightness

Make sure you read the following before you use the projector.

☛ [Safety Instructions](#)

Warning and Cautions on Installation

An optional ceiling mount is required when suspending the projector from a ceiling.

☛ "Optional Accessories" [p.236](#)

Warning

- This is a class A product. In a domestic environment this product may cause radio interference in which case the user may be required to take adequate measures.
- Do not use or install the projector where it may be subject to water or rain, or high humidity, such as outdoors, in a bathroom, or shower room, and so on. Otherwise, it could cause a fire or electric shock.
- Do not install in locations where salt damage could occur, or in locations subject to corrosive gas such as sulphuric gas from hot springs. Otherwise, corrosion could cause the projector to fall. It could also cause the projector to malfunction.
- A special method of installation is required when suspending the projector from a ceiling (ceiling mount). If installation work is not carried out correctly, the projector could fall down. This may result in injury or accidents. Contact your local dealer or the nearest address provided in the Epson Projector Contact List.
☛ [Epson Projector Contact List](#)
- If you use adhesives on the ceiling mount fixing points to prevent the screws from loosening, or if you use things such as lubricants or oils on the projector, the projector case may crack causing it to fall from its ceiling mount. This could cause an accident or injury to anyone under the ceiling mount.
When installing or adjusting the ceiling mount, do not use adhesives to prevent the screws from loosening and do not use oils or lubricants and so on.
- Failure to install the ceiling mount and projector may cause the projector to fall.
After installing the specific Epson mount that supports your projector, make sure you secure the projector and the mount using wire that is strong enough to hold their weight.
- Do not cover the projector's air intake vent or air exhaust vent. If either of the vents is covered, the internal temperature could rise and cause a fire.

Warning

- Do not place flammable objects in front of the lens. If you set the schedule to turn on the projector automatically, any flammable objects placed in front of the lens could cause a fire.
- Do not tie the power cord and other connection cables together. Otherwise, it could cause a fire.
- Only use the specified power-supply voltage. Otherwise, it could cause a fire or electric shock.
- Be careful when handling the power cord. Otherwise, it could cause a fire or electric shock. Note the following when handling the power cord.
 - Do not plug multiple power cords in a single electric outlet.
 - Do not plug in the power cord if there are any foreign substances, such as dust, stuck to it.
 - Make sure you insert the power cord all the way in.
 - Do not plug in or unplug the power cord with wet hands.
 - Do not pull the cord when unplugging the power cord. Make sure you hold it by the plug.
- Do not use a damaged power cord. Otherwise, it could cause a fire or electric shock. Note the following when handling the power cord.
 - Do not alter the power cord.
 - Do not place any heavy objects on the power cord.
 - Do not bend, twist, or pull the power cord forcibly.
 - Do not layout the power cord near a heating device.

Caution

Do not place the projector on an unstable surface, such as on an unstable table or tilted surface. Install the projector appropriately to prevent the projector from falling. Otherwise it may cause an injury.

Attention

- Do not install the projector in a location that is subject to vibration or shock.
- Do not install the projector near a high-voltage line or object that generates magnetism. Otherwise the projector may not work correctly.
- Do not use or store the projector in a location that is subject to extreme temperatures. Also, avoid sudden temperature changes. Make sure you maintain the operating or storage temperature ranges.
 - ☛ "Projector General Specifications" p.249
- Do not install the projector in direct sunlight. If the projector is in direct sunlight, the internal temperature increases, which could cause parts such as the surface of the projection lens or the built-in camera to deteriorate.
- When installing the projector in an environment in which a high-powered laser beam is being used, make sure it is installed so that the laser beam does not hit the surface of the projection lens.
- When using at an altitude that exceeds 1,500 m, set **High Altitude Mode** to **On**.
 - ☛ **Extended - Operation - High Altitude Mode** p.143
- The projector can be installed at any angle. There is no vertical or horizontal limit to how the projector can be installed.

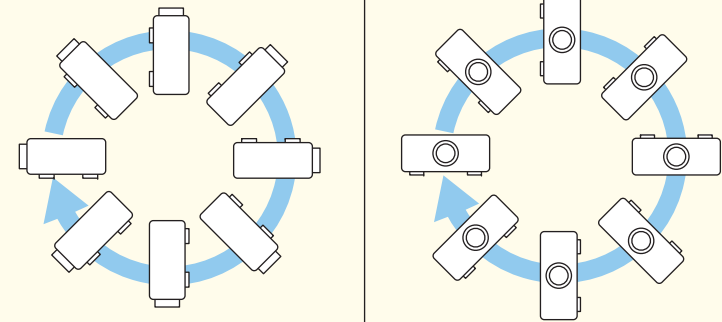

Attention

- You may need dedicated installation mounts to tilt and install the projector. Contact a specialist and prepare the mount.
- Plan so that the mount does not fall.
- Make sure you secure the following space around the projector so as not to block the air exhaust vent and the air intake vent.

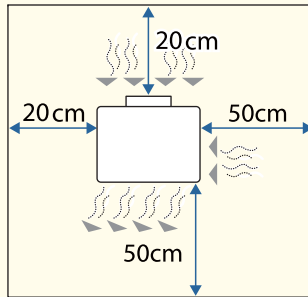

- When setting up multiple projectors, make sure there is a gap of at least 50 cm between the projectors. Also, make sure that the heat from the air exhaust vent does not go into the air intake vent.

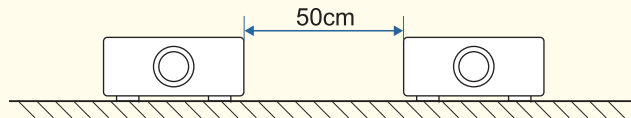

- Note the following points when projecting from projectors directly on top of another.
 - Do not stack three or more projectors.
 - Tilt the projector within the extendable range of the feet.
 - Install the projector so that it does not fall over.
 - When using the projector's feet, make sure that all of the feet are firmly placed on the projector below.

Attention

- When installing the projector with the air intake vent facing down, make sure there is a gap of at least 10 cm between the projector and the floor and so on. Make sure there is a space of 20 x 20 cm for the base so that the air intake vent is not blocked.

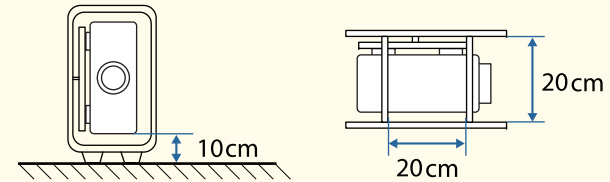

- When using the ceiling mount or the portrait mount, use commercially available M6 screws (up to a depth of 27 mm) to fix the projector's ceiling mount fixing points and the mount at four points.

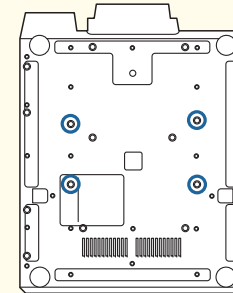

Attention

- When using a clamp to attach the projector to an aluminum truss, attach the clamp to at least four points so that it is symmetrical with the eight screw holes for the clamp. When installing using four points, use the following screw hole combinations. The M6 screws for the clamp must be longer than 10 mm (with a max of 27 mm). You cannot install if the distance between the center of the aluminum truss pipe and the center does not match the distance between the screw holes.

☞ "Appearance" p.254

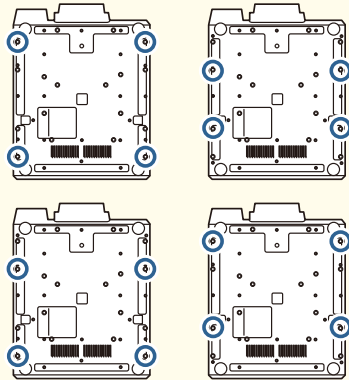

- When installing the projector in a high location such as on a wall, hanging from a ceiling, or an aluminum truss, make sure you take measures against the projector falling such as attaching a commercially available drop-prevention wire to the mounting section.



- We recommend setting the focus, zoom, and lens shift at least 30 minutes after you start the projection, because images are not stable right after turning on the projector.
- When adjusting the image height with the vertical lens shift, adjust by moving the image from the bottom to the top. If it is adjusted from the top to the bottom, the image position may move down slightly after adjusting.

Warnings and Cautions on Lifting



Caution

- Use the four eye bolts installed on the same surface of the projector to lift it.

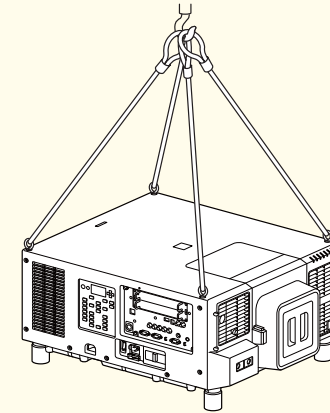

- Only use the eye bolts when temporarily transporting the projector and not for permanent installation. The projector could be damaged or could malfunction.
- Do not lift the projector with the front/back/side of the projector facing up.
- Make sure that the angle when lifting is 60 degrees or more.

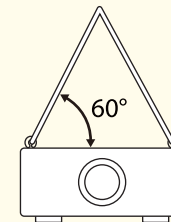

Attention

Use four commercially available eyebolts M6 (ankle length 12 to 27 mm) to attach to the four eye hole screw holes.

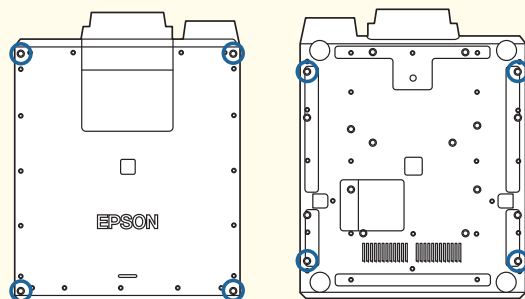

Warning and Cautions on Usage

Warning

- Do not cover the projector's air intake vent or air exhaust vent. If either of the vents is covered, the internal temperature could rise and cause a fire.
- Do not place a cloth or any paper under the projector. The cloth or paper could be sucked up by the Air intake vent on the bottom of the projector during projection causing the internal temperature to rise which could start a fire.
- Do not look into the lens while projecting. The powerful light emitted could cause damage to eyesight. Take particular care when there are children present. Also, do not look through the lens using optical equipment such as a magnifying glass or telescope. When turning on the projector at a distance using the remote control, make sure there is no one looking into the lens.
- During projection, do not block the light from the projector with the lens cover (removable) or a book and so on.
If the light from the projector is blocked, the area on which the light shines becomes hot which could cause it to melt, burn, or start a fire. Also, the lens may get hot due to the reflected light which could cause the projector to malfunction. To stop projection, use the Shutter function, or turn off the projector.
- Do not open the projector's case. Never disassemble or remodel the projector. There are high-voltage components inside the projector that could cause fire, electric shock, or an accident.
- If an error occurs, disconnect the power cord from the electrical outlet, and contact your local dealer or the nearest address provided in the Epson Projector Contact List. If you continue using the projector as it is, it could cause an electric shock, fire, or even damage to eyesight.

 [Epson Projector Contact List](#)

Caution

- Do not place objects that may become warped or otherwise affected by heat near the air exhaust vent and do not put your face or hands near the vent while projection is in progress.
- Special techniques are required to install and remove the interface board, so make sure you contact a specialist. Otherwise, unexpected malfunctions could occur due to static electricity and so on.
- Turn off the projector and unplug the power plug from the outlet before installing/removing the interface board.

Attention

- When you purchase the projector, a protective cap is installed in the lens unit installation section. Install the protective cap when the lens unit is not installed. If dust or dirt enter the projector, projection quality deteriorates and it could cause a malfunction.
- Make sure the interface boards are always installed in the slots. If dust or dirt enter the projector, it could cause a malfunction.
- When a high-powered laser beams through the surface of the projection lens, it can cause a malfunction in the LCD panel. If the laser can beam through the surface of the projection lens, block the laser beam with non-permeable or incombustible aluminum foil or metal plates such as iron to protect the projection lens. You can also use the projector's Shutter function to prevent the LCD panel from being damaged by laser light.
 - ☛ "Hiding the Image Temporarily (Shutter)" [p.102](#)
- When high-powered laser beams enter the built-in camera, they can cause a malfunction. Make sure you attach the protection plate to the built-in camera.
 - ☛ "Rear/Side" [p.19](#)

Attention

- Try not to touch the lens section with your hand or fingers. If fingerprints or oils are left on the surface of the lens, projection quality deteriorates.
- If you continue to project while the surface of the lens is dirty, projection quality deteriorates. Make sure you clean the lens.
 - ☛ "Cleaning the Lens" [p.204](#)
- When storing, make sure you remove the batteries from the remote control. If the batteries are left in the remote control for an extended period of time, they may leak.
- When using the projector in smoky environments such as at events and so on, make sure you replace the air filter after approximately 240 hours of use. (This is a guideline when using the projector in an environment with an atmospheric concentration of ondina oil of approximately 0.00000013%. The air filter replacement time may be shorter depending on the operating environment.)

Using the projector in a smoky environment may cause the filter's dust collection function to decline and dust may adhere to the inside of the projector or the power supply; this may cause a malfunction to occur.

 - ☛ "Replacing the Air Filter" [p.208](#)



- About the LCD panel

The LCD panel may contain pixels that are missing or appear bright all the time. This is not a sign of an error.

- About the light source

The projector uses a laser as the light source. The laser has the following characteristics.

- Depending on the surroundings, the brightness of the light source may decline. The brightness declines a lot when the temperature gets too high.
- The brightness of the light source declines the longer it is used. You can change the relationship between operation time and decline in brightness in **Brightness Settings**.

☛ "Relationship between Brightness Level and light source operation time" [p.78](#)

- About light source calibration

- When **Run Periodically** is set to **On** for light source calibration, every time the operation time reaches 100 hours, calibration starts automatically for the light source when the projector is turned off. However, light source calibration does not start automatically in the following situations.

- Within 30 minutes of turning on the projector
- When using the Shutter function
- Within 30 minutes of releasing the Shutter function
- When the projector is used continuously for over 24 hours
- When using direct shutdown

- When performing Light Source Calibration, the differences in the White Balance and the Brightness Level for the light source are corrected.

☛ **Reset - Light Source Calibration - Run Periodically** [p.159](#)

Warning and Cautions on the Laser

Warning

- Laser warning labels are attached to the projector.

Inside



Side

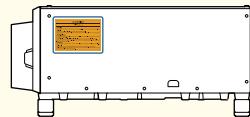
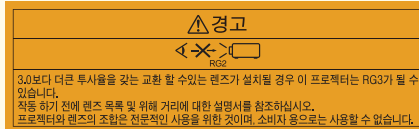
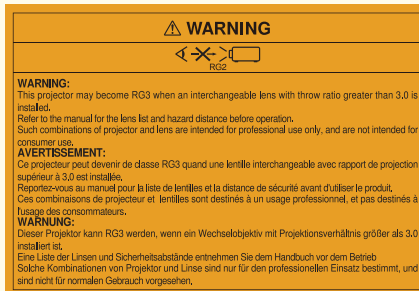

Warning

- Do not open the projector's case. The projector contains a high-powered laser.
- Possibly hazardous optical radiation emitted from this product. Do not look at operating light source. Eye injury may result.
- Do not look into the laser beam being emitted from the light source while projecting. (Based on the RG2 IEC/EN 62471-5: 2015)
- This projector may become RG3 when an interchangeable lens with throw ratio greater than 3.0 is installed. Refer to the manual for the lens list and hazard distance before operation. Such combination of projector and lens are intended for professional use only, and are not intended for consumer use.

Caution

- This projector is a Class 1 laser product that complies with the IEC/EN60825-1:2014 international standard for lasers.
- Do not disassemble the projector when disposing of it. Dispose according to your local or national laws and regulations.

Notes on Transporting

There are many glass parts and precision components inside the projector. To prevent damage due to impacts when transporting, handle the projector as follows.



Caution

The projector should not be carried by one person. At least three people are needed to unpack or carry the projector.

Attention

- Moving Nearby
 - Turn off the power to the projector and disconnect all cables.
 - Attach the cover to the lens.

- When Transporting

After checking the points in "Moving Nearby", prepare the following and then pack up the projector.

 - Remove the lens unit if a lens is installed. Make sure you attach the protective cap that was on the lens mount when you purchased the projector.
 - Enclose the projector securely in packaging material to protect it from shock, and place it into a strong container. Be sure to notify the carrier company that it is precision equipment and that it needs to be kept horizontally during transportation.

Notations Used in This Guide 2

Introduction

Part Names and Functions 18

Front/Top	18
Rear/Side	19
Connector Ports	20
Interface boards	21
Base	22
Control Panel	23
Remote Control	25
Handy remote control operations	27
Replacing the remote control batteries	27
Remote control operating range	28
Connecting a cable to the remote control	29

Preparing the Projector

Installing the Projector 31

Removing and Attaching the Projector Lens Unit	31
Attaching	31
Lens Calibration	33
Removing	34
Installation Settings	35
Changing the direction of the image (projection mode)	35
Screen Settings	36
Adjusting the position of the image on the projected screen	36
Displaying the Test Pattern	37
Adjusting the Position of the Projected Image (Lens Shift Adjustment)	38
Adjusting the Image Size	40
Correcting the Focus	41
Correcting Distortion (Image Warping)	42
Registering and Loading Lens Adjustment Values	43
Panel Alignment	44

Adjusting the Tilt (for Normal Installation)	46
ID Settings	46
Set the projector ID	47
Checking the projector ID	47
Setting the remote control ID	47
Setting the Time	48
Other Settings	49
Settings related to basic operations	49
Settings related to display	50

Connecting Equipment 51

Connecting a Computer	51
Connecting Image Sources	52
Connecting to an External Monitor	54
Connecting a LAN Cable	56
Connecting an HDBaseT Transmitter	57

Basic Usage

Turning On the Projector 59

Turning Off the Projector 61

Changing the Projected Image 62

Adjusting Projected Images 65

Correcting Distortion in the Projected Image	65
H/V-Keystone	66
Quick Corner	67
Curved Surface	68
Corner Wall	71
Point Correction	75
Selecting the Projection Quality (Selecting Color Mode)	76
Setting the Brightness	77
Guide to Estimated Remains	78
Relationship between Brightness Level and light source operation time	78
Setting the Amount of Light of the Projected Image	79
Changing the Aspect Ratio of the Projected Image	80

- Changing methods 80
- Adjusting the Image 81
 - Hue, Saturation, and Brightness adjustment 81
 - Gamma adjustment 82
- Adjusting Image Resolution (Image Enhancement) 83
 - Image Preset Mode 83
 - Noise Reduction 83
 - Detail Enhancement 84

- Memory Function 105**
 - Saving/Loading/Erasing/Resetting the Memory 105
- Scheduling Function 107**
 - Saving an Event 107
 - Setting an Event 107
 - Checking an Event 108
 - Editing an Event 109

- Security Functions 111**
 - Managing Users (Password Protection) 111
 - Kinds of Password Protection 111
 - Setting Password Protection 111
 - Entering the password 112
 - Restricting Operation 113
 - Control Panel Lock 113
 - Lens Lock 114
 - Remote control button lock 114

Useful Functions

- Multi-Projection Function 86**
 - Adjustment Procedure 86
 - Adjusting automatically online 86
 - Adjusting manually offline 87
 - Tiling 88
 - Performing tiling automatically 88
 - Performing tiling manually 89
 - Edge Blending 90
 - Black Level 92
 - Area Correction 93
 - Screen Matching 94
 - Operating conditions for auto adjustment functions 95
 - Automatically correct the brightness and tint for multiple projectors 95
 - Color Matching 96
 - Displaying a Scaled Image 97
 - Tiling Assist 98
 - Operating conditions for auto adjustment functions 99
- Projection Functions 100**
 - Projecting Two Images Simultaneously (Split Screen) 100
 - Combinations of sources that cannot project in split screen 100
 - Operating procedures 100
 - Restrictions during split screen projection 102
 - Hiding the Image Temporarily (Shutter) 102
 - Freezing the Image (Freeze) 103
 - Saving a User's Logo 103

Using the Projector on a Network

- Wired Network Projection 117**
 - Selecting Wired Network Settings 117
- Wireless Network Projection 119**
 - Selecting Wireless Network Settings Manually 119
 - Selecting Wireless Network Settings in Windows 121
 - Selecting Wireless Network Settings in Mac 121
 - Setting Up Wireless Network Security 122
 - Supported Client and CA Certificates 123
 - Using a QR Code to Connect a Mobile Device 124
 - Using a USB Key to Connect a Windows Computer 125
- Setting a Static IP Address Using the LCD Display 127**
- Secure HTTP 128**
 - Importing a Web Server Certificate Using the Menu 128



Supported Web Server Certificates 129
 Setting a certificate using a Web browser 129

Configuration Menu

Configuration Menu Operations 132

List of Functions 134

Configuration Menu Table 134

 Network menu 135

Image Menu 137

Signal Menu 138

Settings Menu 141

Extended Menu 143

Network Menu 148

 Notes on operating the Network menu 149

 Soft keyboard operations 150

 Basic menu 150

 Wireless LAN menu 151

 Wired LAN menu 155

 Notifications menu 155

 Others menu 157

 Reset menu 157

Info Menu (Display Only) 158

Reset Menu 159

Batch Setup 161

Setup Using a USB Flash Drive 162

 Saving settings to the USB flash drive 162

 Reflecting saved settings to other projectors 164

Setup by Connecting the Computer and Projector with a USB Cable 165

 Saving settings to a computer 165

 Reflecting saved settings to other projectors 166

When Setup Fails 168

Troubleshooting

Using the Help 170

Reading the Indicators 171

Understanding the Status Information 178

 Checking the Status 178

 Understanding the screen 179

 Setting the screen display (LCD) 180

 Explanations of the Display Content 181

Problem Solving 189

Problems Relating to Images 190

 No images appear 190

 Moving images are not displayed 191

 Projection stops automatically 191

 Not supported is displayed 191

 No Signal is displayed 191

 Images are fuzzy, out of focus, or distorted 192

 Interference or distortion appear in images 192

 The image is truncated (large) or small, the aspect is not suitable, or the image has been reversed 193

 Image colors are not right 194

 Images appear dark 195

 Automatic adjustments are not performed correctly 195

Problems when Projection Starts 196

 The projector does not turn on 196

Other Problems 197

 The remote control does not work 197

 Cannot control correctly using Art-Net 198

 Nothing appears on the external monitor 199

 I want to change the language for messages and menus 199

 Email is not received even if a problem occurs in the projector 199

 The battery that saves your clock settings is running low. is displayed 199

 The projector did not turn off correctly. is displayed 200

 Detailed logs and error message are not displayed 200

 An error occurred in the interface board. is displayed 200



About Event ID 201

Maintenance

Cleaning the Parts 204

Cleaning the Projector 204
 Cleaning the Lens 204
 Cleaning the Air Filter and Air Intake Vent 204
 Cleaning the air filter 205
 Cleaning the air intake vent 207

Replacing Consumables 208

Replacing the Air Filter 208
 Air filter replacement period 208
 Replacing the air filter 208

Image Maintenance 210

Color Calibration 210
 Color Uniformity 211

Appendix

Monitoring and Controlling 214

About Epson Projector Management 214
 Changing Settings Using a Web Browser (Epson Web Control) 214
 Displaying the Epson Web Control Screen 214
 Basic Control Screen 215
 OSD Control Pad Screen 216
 Lens Control Screen 217
 Status Information Screen 219
 Remote Camera Access Screen 219
 Using the Mail Notification Function to Report Problems 222
 Reading error notification mail 222
 Management Using SNMP 223
 ESC/VP21 Commands 223
 Command list 223

Cable layouts 224
 About PJLink 225
 About Crestron Connected® 225
 Operating a projector from your computer 226
 About Art-Net 230
 Channel definitions 230

Optional Accessories and Consumables 236

Optional Accessories 236
 Consumables 236

Screen Size and Projection Distance 237

Lens Type and Projection Range 237
 Projection Distance 237
 Projection distance ratio by lens 237
 Screen Size 238

Adjustment Range for Projected Images 239

H/V-Keystone 239
 Curved Surface 239
 Corner Wall 243

Supported Monitor Displays 246

Supported Resolutions 246
 Computer signals (analog RGB) 246
 Component Video 246
 Input signals from the DVI-D In port, HDMI In port, HDBaseT port, and DisplayPort In port 246
 Input signals from SDI In port 248

Specifications 249

Projector General Specifications 249

Appearance 254

General Notes 255

About Notations 255
 Trademarks and Copyrights 255

List of Safety Symbols 257



Index 259



Introduction



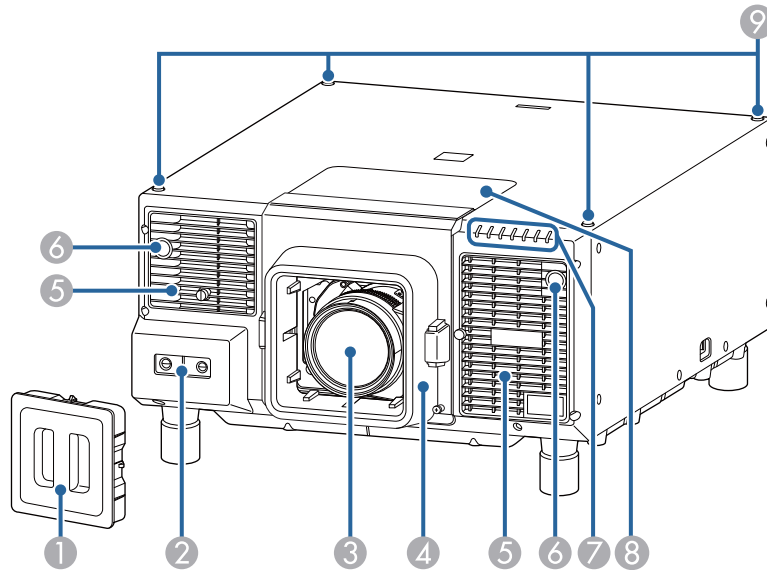

This chapter explains the names for each part.

Unless otherwise mentioned, the illustrations used in this guide show the projector with the lens unit (ELPLM15) installed.

Front/Top



Name	Function
① Protective cap	Install this when storing or transporting the projector.
② Built-in camera	This camera scans the image when correcting the projected image automatically. <div style="border: 1px solid black; padding: 5px; margin-top: 10px;"> <p>Attention</p> <p>Exposing the camera to bright light may cause a malfunction to occur.</p> </div>



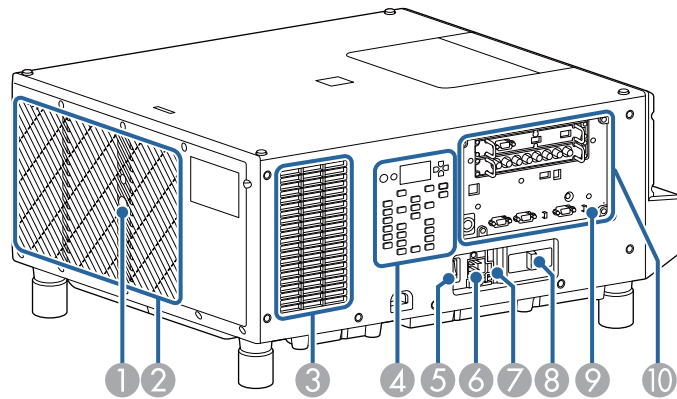

Name	Function
③ Projection lens	<p>Images are projected through here.</p> <div style="border: 1px solid black; padding: 5px; margin-top: 10px;"> <p>Warning</p> <p>This section emits laser light. Do not look into the lens while projecting. This could cause damage to eyesight due to the powerful light emitted.</p> </div> <div style="border: 1px solid black; padding: 5px; margin-top: 10px;"> <p>Caution</p> <p>When shifting the lens, do not put your hands near the lens unit. Your fingers may get caught between the lens unit and the projector, and cause an injury.</p> </div>
④ Lens replacement cover	<p>Remove when attaching or removing the lens.</p> <p> "Removing and Attaching the Projector Lens Unit" p.31</p> <div style="border: 1px solid black; padding: 5px; margin-top: 10px;"> <p>Caution</p> <p>When moving the projector, do not hold the lens replacement cover. The lens replacement cover may be removed and the projector may fall, which could cause an injury.</p> </div>
⑤ Air intake vent (air filter)	<p>Takes in air to cool the projector internally. Be sure to clean the air filter regularly.</p> <p> "Cleaning the Air Filter and Air Intake Vent" p.204</p> <p> "Replacing the Air Filter" p.208</p>
⑥ Remote receiver	Receives signals from the remote control.
⑦ Status indicators	<p>The color of the indicators and whether they are flashing or lit indicate the status of the projector.</p> <p> "Reading the Indicators" p.171</p>

Name	Function
8 Lens replacement cover (for ELPLX02/ELPLX02W)	Remove when installing the lens unit (ELPLX02/ELPLX02W).
9 Screw holes for eye bolts	You can attach a commercially available eye bolt when temporarily transporting the projector.

Rear/Side

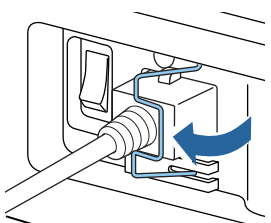
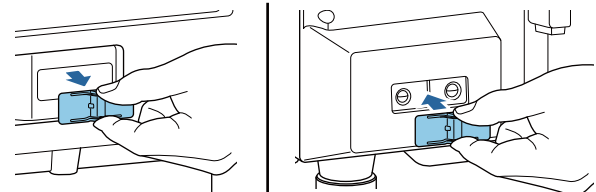

Name	Function
1 Remote receiver	Receives signals from the remote control.
2 Air exhaust vent	Exhaust vent for air used to cool the projector internally. <div style="border: 1px solid black; padding: 5px; background-color: #ffffcc;"> <p>⚠ Caution</p> <p>While projecting, do not put your face or hands near the air exhaust vent, and do not place objects that may become warped or damaged by heat near the air exhaust vent. Hot air from the air exhaust vent could cause burns, warping, or accidents to occur.</p> </div>

Name	Function
3 Air intake vent	Takes in air to cool the projector internally. Be sure to clean the air intake vent regularly.  "Cleaning the Air Filter and Air Intake Vent" p.204
4 Control panel	 "Control Panel" p.23
5 Main power switch	Supplies power to the projector.
6 Power inlet	Connects the power cord to the projector.
7 Cable holder	Attach this to the power cord to prevent the cord from falling out. 
8 Built-in camera protection plate	Attach this to the built-in camera so that lasers from other equipment do not enter the built-in camera when using the projector with other devices that emit laser beams. 
9 Security slot	The security slot is compatible with the Microsaver Security System manufactured by Kensington. See the following for more details on the Microsaver Security System. http://www.kensington.com/
10 Interface	 "Connector Ports" p.20

Connector Ports

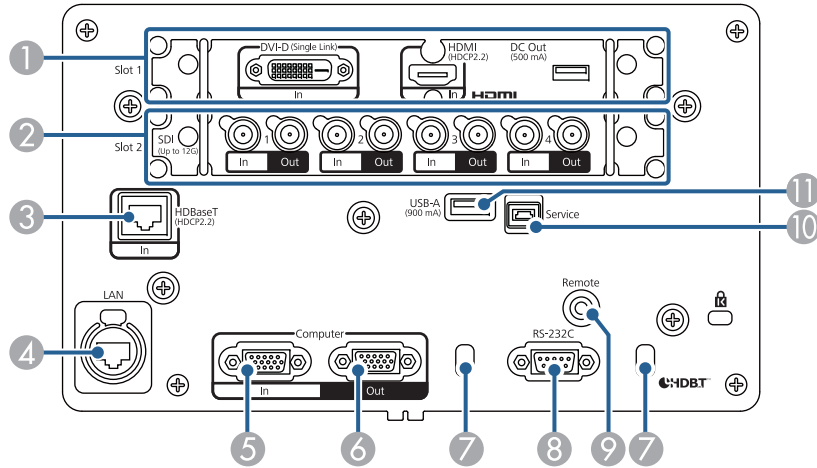

Name	Function
1 Slot1	Slots for installing interface boards. You can also replace these with optional interface boards. ☛ "Interface boards" p.21
2 Slot2	
3 HDBaseT port	Connects a LAN cable to the optional HDBaseT Transmitter. ☛ "Connecting an HDBaseT Transmitter" p.57 ☛ "Optional Accessories" p.236 The projector supports Art-Net. When using Art-Net to control the projector, set Art-Net to On from the Network menu. ☛ Network - Others - Art-Net p.157
4 LAN port (Supports etherCON LAN cables)	Connects a LAN cable to connect to a network. The projector supports Art-Net. When using Art-Net to control the projector, set Art-Net to On from the Network menu. ☛ Network - Others - Art-Net p.157

Name	Function
5 Computer In port	For analog RGB signals from a computer and component video signals from other video sources.
6 Computer Out port	Connects to an external monitor, and outputs analog RGB signals from the computer being input to the Computer In port. You cannot output signals input from other ports or component video signals.
7 Cable holder	Run a commercially available cable tie to secure cables.
8 RS-232C port	When controlling the projector from a computer, connect it to the computer with an RS-232C cable. ☛ "ESC/VP21 Commands" p.223
9 Remote port	Connects the optional remote control cable set and inputs signals from the remote control. When the remote control cable is plugged into the Remote port, the remote receiver on the projector is disabled. ☛ "Optional Accessories" p.236
10 Service port	This is used for batch settings. This port is for control use and should not normally be used. ☛ "Batch Setup" p.161
11 USB-A port	This is used for batch settings. ☛ "Batch Setup" p.161 Connects a USB flash drive to save the projector's operation logs. ☛ Extended - Operation - Log Save Destination p.143 Connects to the power port for the video receiver, network equipment, or optical HDMI cable (for extending). Operations for all equipment are not guaranteed. Check that you can operate your equipment when using this connector.

Interface boards

An HDMI/DVI-D interface board is installed in Slot 1 on the projector, and an SDI interface board is installed in Slot 2.

You can also replace these with optional interface boards. For more details, see the user's guide supplied with the interface board.

Caution

- Special techniques are required to install and remove the interface board, so make sure you contact a specialist. Otherwise, unexpected malfunctions could occur due to static electricity and so on.
- Turn off the projector and unplug the power plug from the outlet before installing/removing the interface board.

HDMI/DVI-D interface board (ELPIF01)

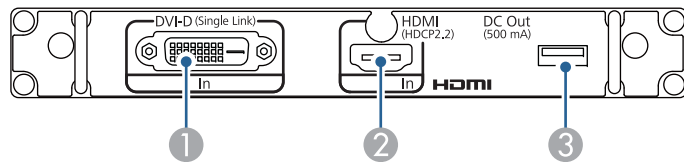

Name	Function
① DVI-D In port	Inputs the computer DVI-D signals.
② HDMI In port	Inputs video signals from HDMI compatible video equipment and computers.
③ DC Out port	Connects the power port for optical HDMI cables. This port is for supplying power only and cannot be use for communication. Operations for all equipment are not guaranteed. Check that you can operate your equipment when using this connector.

SDI interface board (ELPIF02)

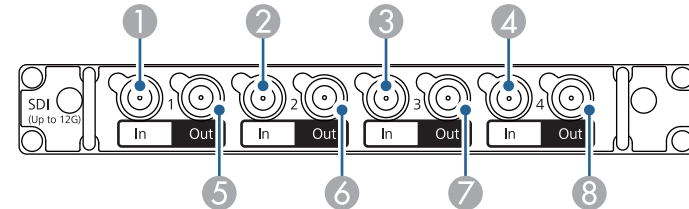

Name	Function
① SDI1 In port	Inputs SDI signals. The SDI1 In port supports single-link 12G-SDI signals. The projector supports quad-link signals. When a quad-link 3G-SDI signal is being input, set the link type in SDI Settings for the slot in which the SDI interface board is installed. Extended - SDI Settings p.143
② SDI2 In port	
③ SDI3 In port	
④ SDI4 In port	
⑤ SDI1 Out port	Outputs SDI signals being input from the SDI In port. The SDI1 Out port supports single-link 12G-SDI signals.
⑥ SDI2 Out port	
⑦ SDI3 Out port	
⑧ SDI4 Out port	

DisplayPort interface board (ELPIF03)

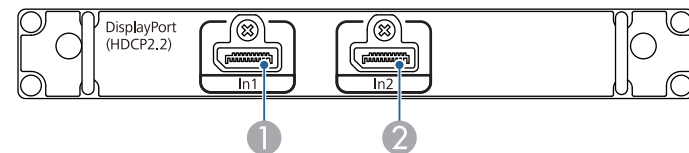

Name	Function
① DisplayPort1 In port	Inputs signals for computers that support DisplayPort. You can connect two cables to the DisplayPort1 In and DisplayPort2 In ports to input 4K 100 Hz/120 Hz signals. Set the Link Type in DisplayPort Settings .

Name	Function
2 DisplayPort2 In port	Extended - DisplayPort Settings p.143

Base

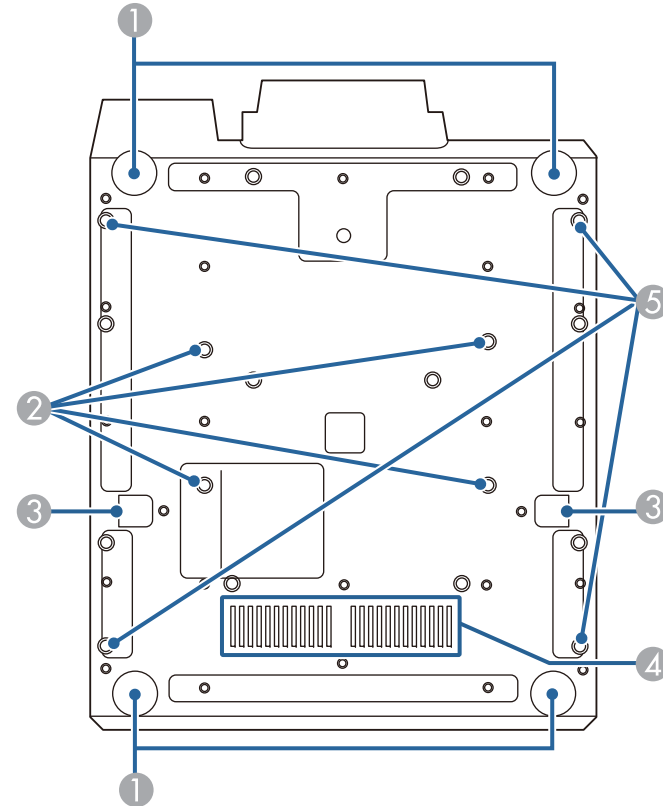

Name	Function
1 Feet	<p>When setup on a surface such as a desk, turn to extend and retract to adjust the horizontal tilt.</p> <p>Extended - "Adjusting the Tilt (for Normal Installment)" p.46</p> <div style="border: 1px solid black; padding: 5px; margin-top: 10px;"> <p>Attention</p> <p>Do not attach any other mounts to the foot fixing points. The projector could be damaged or could malfunction.</p> </div>

Name	Function
2 Ceiling mount fixing point (ELPMB47/ELPMB48)	Attach the optional ceiling mount here when suspending the projector from a ceiling. 🖱️ "Installing the Projector" p.31 🖱️ "Optional Accessories" p.236
3 Drop-prevention Wire Installation Point	When installing the projector in a high location such as on a wall, hanging from a ceiling, or an aluminum truss, install a commercially available drop-prevention wire (that supports a weight of at least 100 kg). Make sure you attach the wire to the points on the left and right. Make sure there is no slack in the wire when you install the projector. For more information, see the user's guide supplied with the wire.
4 Air intake vent	Takes in air to cool the projector internally. Be sure to clean the air intake vent regularly. 🖱️ "Cleaning the Air Filter and Air Intake Vent" p.204
5 Screw holes for eye bolts	You can attach a commercially available eye bolt when temporarily transporting the projector.

Control Panel

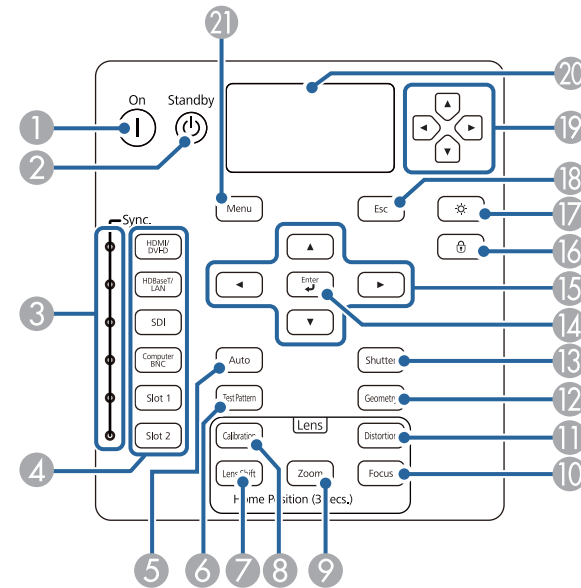

Name	Function
1 [On] button	Starts projection when the main power switch is on and the projector is in standby mode.
2 [Standby] button	Places the projector in standby mode when the main power switch is on and it is projecting.
3 Sync indicator	The light for the source that detects the video signal turns on.
4 Change input buttons	Changes to images from each input port. The light turns on for the button of the source being projected. 🖱️ "Changing the Projected Image" p.62
5 [Auto] button	If you press this button while projecting analog RGB signals from the Computer In port, you can automatically optimize Tracking, Sync., and Position.

Name	Function
6 [Test Pattern] button	Displays a test pattern. ☛ "Displaying the Test Pattern" p.37
7 [Lens Shift] button	Press to adjust the lens shift. ☛ "Adjusting the Position of the Projected Image (Lens Shift Adjustment)" p.38 If pressed for more than three seconds, the lens position moves to the home position.
8 [Calibration] button	Executes lens calibration. ☛ "Lens Calibration" p.33
9 [Zoom] button	Press to adjust the zoom. ☛ "Adjusting the Image Size" p.40
10 [Focus] button	Adjusts the focus. ☛ "Correcting the Focus" p.41
11 [Distortion] button	Corrects distortion. ☛ "Correcting Distortion (Image Warping)" p.42
12 [Geometry] button	Corrects distortion in the projected image. ☛ "Correcting Distortion in the Projected Image" p.65
13 [Shutter] button	Press to turn the image on or off temporarily. ☛ "Hiding the Image Temporarily (Shutter)" p.102
14 [↵] button	When the Configuration menu or the Help screen is displayed, it accepts and enters the current selection and moves to the next level. ☛ "Configuration Menu Operations" p.132

Name	Function
15 [▲][▼][◀][▶] buttons	<ul style="list-style-type: none"> Press to adjust focus, distortion, zoom, and lens shift. <ul style="list-style-type: none"> ☛ "Adjusting the Position of the Projected Image (Lens Shift Adjustment)" p.38 ☛ "Adjusting the Image Size" p.40 ☛ "Correcting the Focus" p.41 If pressed when the Configuration menu or the Help screen is displayed, menu items and setting values are selected. <ul style="list-style-type: none"> ☛ "Configuration Menu Operations" p.132
16 [🔒] button	Displays the Control Panel Lock screen allowing you to make settings to lock the control panel buttons. ☛ "Restricting Operation" p.113
17 [☀️] button	Press to turn on or off the buttons on the control panel and the LCD display.
18 [Esc] button	<ul style="list-style-type: none"> Stops the current function. If pressed when the Configuration menu is displayed, it returns to the previous menu level. <ul style="list-style-type: none"> ☛ "Configuration Menu Operations" p.132
19 [⏪][⏩][⏴][⏵] buttons	Select menu items and settings displayed on the LCD display.
20 LCD display	Displays the projector's status by character information. ☛ "Understanding the Status Information" p.178 Displays the static IP address setting menu. ☛ "Setting a Static IP Address Using the LCD Display" p.127
21 [Menu] button	Displays and closes the Configuration menu. ☛ "Configuration Menu Operations" p.132

Remote Control

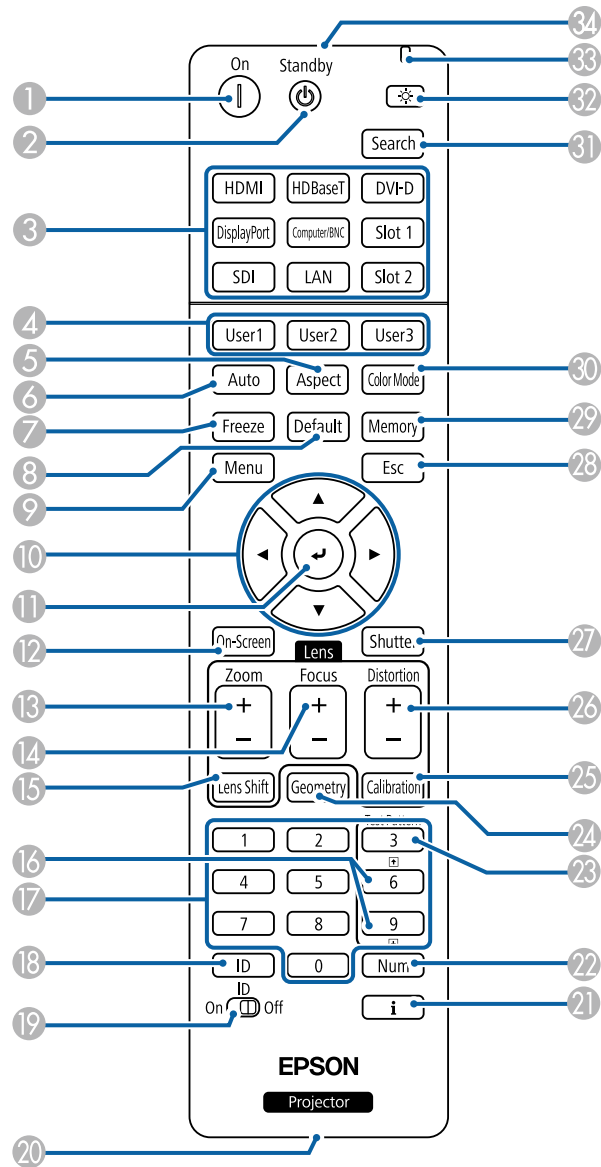

	Name	Function
1	[On/Standby] button	Starts projection when the main power switch is on and the projector is in standby mode.
2	[Standby] button	Places the projector in standby mode when the main power switch is on and it is projecting.
3	Change input buttons	Changes to images from each input port. ☛ "Changing the Projected Image" p.62
4	[User1] button [User2] button [User3] button	Select any frequently used item from the Configuration menu items, and assign it to any of these buttons. By pressing the button, the assigned menu item selection/adjustment screen is displayed, allowing you to make one-touch settings/adjustments. ☛ "Settings Menu" p.141
5	[Aspect] button	Each time the button is pressed, the aspect mode changes. ☛ "Changing the Aspect Ratio of the Projected Image" p.80
6	[Auto] button	If you press this button while projecting analog RGB signals from the Computer In port, you can automatically optimize Tracking, Sync., and Position.
7	[Freeze] button	Images are paused or unpaused. ☛ "Freezing the Image (Freeze)" p.103
8	[Default] button	Enabled when [Default]: Reset is displayed on the configuration menu guide. The settings being adjusted are returned to their default values. ☛ "Configuration Menu Operations" p.132
9	[Menu] button	Displays and closes the Configuration menu. ☛ "Configuration Menu Operations" p.132
10	[▲][▼][◀][▶] buttons	<ul style="list-style-type: none"> • Press to adjust focus, zoom, distortion, and lens shift. • When the Configuration menu or the Help screen is displayed, pressing these buttons selects menu items and setting values. ☛ "Configuration Menu Operations" p.132

Name	Function
11 [↵] button	When the Configuration menu or the Help screen is displayed, it accepts and enters the current selection and moves to the next level. ☛ "Configuration Menu Operations" p.132
12 [On-Screen] button	Shows or hides the Configuration.
13 [Zoom] button	Press to adjust the zoom. ☛ "Adjusting the Image Size" p.40
14 [Focus] button	Press to adjust the focus. ☛ "Correcting the Focus" p.41
15 [Lens Shift] button	Press to adjust the lens shift. ☛ "Adjusting the Position of the Projected Image (Lens Shift Adjustment)" p.38 If pressed for more than three seconds, the lens position moves to the home position.
16 [⏪][⏩] buttons	<ul style="list-style-type: none"> Changes the test pattern displayed. Moves to the previous or next image file when projecting images from a computer connected via a network.
17 Numeric buttons	<ul style="list-style-type: none"> Enter the Password. ☛ "Setting Password Protection" p.111 Use this button to enter numbers in Network settings from the Configuration menu.
18 [ID] button	Hold down this button and press the numeric buttons to select the ID for the projector you want to operate using the remote control. ☛ "ID Settings" p.46
19 [ID] switch	Use this switch to enable (On)/disable (Off) ID settings for the remote control. ☛ "ID Settings" p.46

Name	Function
20 Remote port	Connects the optional remote control cable set and outputs signals from the remote control. ☛ "Optional Accessories" p.236 When the remote control cable is plugged into this remote port, the remote control light-emitting is disabled.
21 [i] button	Displays the Info menu from the Configuration menu. ☛ "Info Menu (Display Only)" p.158
22 [Num] button	Hold down this button and press the numeric buttons to enter passwords and numbers. ☛ "Setting Password Protection" p.111
23 [Test Pattern] button	Displays a test pattern. ☛ "Displaying the Test Pattern" p.37
24 [Geometry] button	Corrects distortion in the projected image. ☛ "Correcting Distortion in the Projected Image" p.65
25 [Calibration] button	Executes lens calibration. ☛ "Lens Calibration" p.33
26 [Distortion] button	Press to correct distortion. ☛ "Correcting Distortion (Image Warping)" p.42
27 [Shutter] button	Press to turn the image on or off temporarily. ☛ "Hiding the Image Temporarily (Shutter)" p.102
28 [Esc] button	<ul style="list-style-type: none"> Stops the current function. If pressed when the Configuration menu is displayed, it moves to the previous level. ☛ "Configuration Menu Operations" p.132
29 [Memory] button	Performs operations and makes settings for the memory function. ☛ "Memory Function" p.105
30 [Color Mode] button	Each time the button is pressed, the Color Mode changes. ☛ "Selecting the Projection Quality (Selecting Color Mode)" p.76

Name	Function
31 [Search] button	Changes to the next input source that is sending an image. ☛ "Changing the Projected Image" p.62
32 [☀] button	Illuminates the buttons on the remote control for approximately 15 seconds. This is useful when using the remote control in the dark.
33 Indicator	A light is emitted when outputting remote control signals.
34 Remote control light-emitting area	Outputs remote control signals.

Operation	Set
Displaying frequently used Configuration menu items.	Press the [User1], [User2], or [User3] button. You can set the menu item you want to assign to each button in User Button . ☛ Settings - User Button p.141 The following items can be assigned. Light Source Mode, Multi-Projection, Resolution, Display the QR Code, Image Enhancement, Screen Matching, Color Calibration, Help, Split Screen

Handy remote control operations

You can perform the following operations by simply pressing one of the buttons on the remote control.

Operation	Set
Reverse the projected image vertically. (Switch the Projection between Front and Front/Ceiling) ☛ "Changing the direction of the image (projection mode)" p.35	Hold down the [Shutter] button for more than five seconds.
Selecting the password security settings. ☛ "Managing Users (Password Protection)" p.111	Hold down the [Freeze] button for more than five seconds. The Password Protection screen is displayed, and you can select various settings.
Locking or unlocking some of the operation of the buttons on the remote control. ☛ "Remote control button lock" p.114	Hold down the [i] button for more than five seconds.
Initializing the settings for the Remote Receiver in the Configuration menu. (Enables all Remote receivers for this projector.)	Hold down the [Menu] button for more than 15 seconds.

Replacing the remote control batteries

If delays in the responsiveness of the remote control occur or if it does not operate after it has been used for some time, it probably means that the batteries are becoming flat. When this happens, replace them with new batteries. Have two AA size alkaline or manganese batteries ready. You cannot use other batteries except for the AA size alkaline or manganese.

Attention

Make sure you read the following manual before handling the batteries.

☛ *Safety Instructions*

- 1 Remove the battery cover.
While pushing the battery compartment cover catch, lift the cover up.

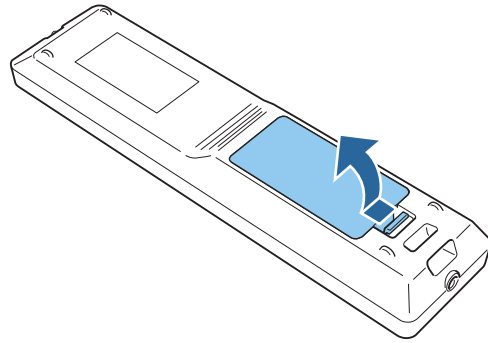

2 Replace the old batteries with new batteries.

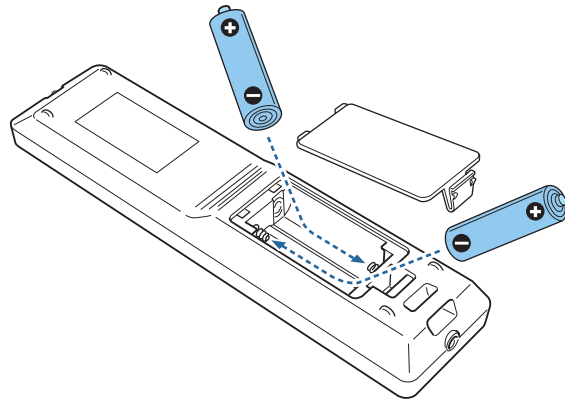

⚠ Caution

Check the positions of the (+) and (-) marks inside the battery holder to ensure the batteries are inserted the correct way.

If the batteries are not used correctly, they could explode or leak causing a fire, injury, or damage to the product.

3 Replace the battery cover.
Press the battery compartment cover until it clicks into place.

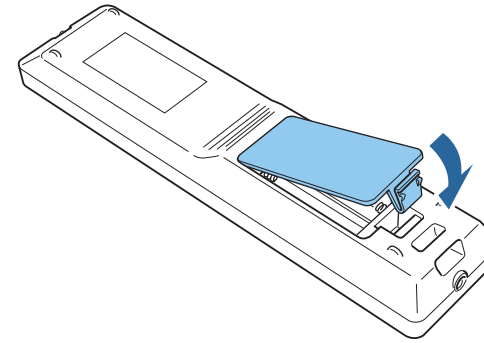

Remote control operating range

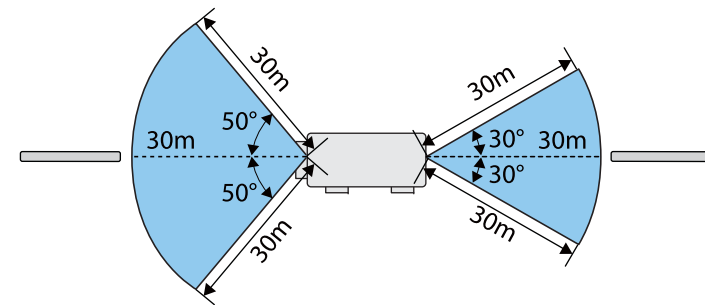
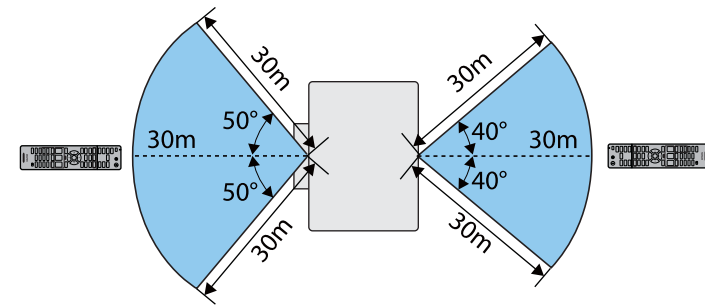



To restrict reception of the operation signals from the remote control, set **Remote Receiver**.

☛ **Settings - Remote Receiver** [p.141](#)

Connecting a cable to the remote control

You can make operations securely with the optional Remote control cable set when you use multiple units of this projector in the same place or when there are obstacles around the remote receiver.

☛ **"Optional Accessories"** [p.236](#)

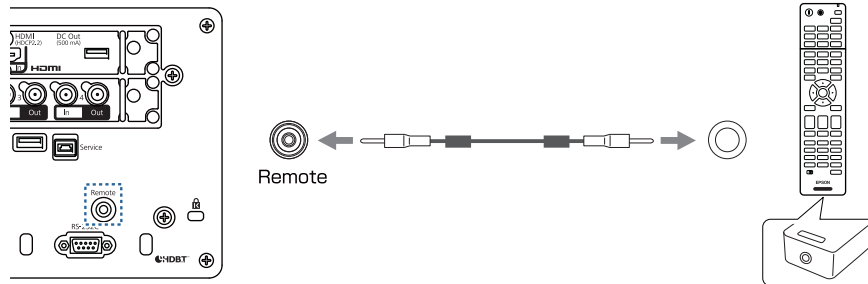

- When the remote control cable is plugged into the Remote port, the remote receiver on the projector is disabled.
- You can also connect the optional HDBaseT transmitter and remote control with the cable to control the projector.

☛ **"Connecting an HDBaseT Transmitter"** [p.57](#)



Preparing the Projector

This chapter explains how to install the projector and connect projection sources.

Removing and Attaching the Projector Lens Unit

Warning

Make sure you disconnect the power cord from the projector before removing or attaching the lens unit to the projector. Otherwise, it could cause an electric shock.

Attaching

Attention

- Do not attach the lens unit when the projector's lens insertion section is facing up. Dust or dirt could enter the projector.
- Try not to touch the lens section with your hand or fingers. If fingerprints or oils are left on the surface of the lens, projection quality deteriorates.



- The projector supports lens with the following model numbers.
ELPLX02, ELPLX02W, ELPLU03, ELPLU03S, ELPLU04, ELPLW05, ELPLW06, ELPLW08, ELPLM09, ELPLM10, ELPLM11, ELPLM15, ELPLL08, ELPLS04, ELPLU02, ELPLR04, ELPLW04, ELPLM06, ELPLM07, ELPLL07

When using the following lenses, make sure you set the **Lens Type** from the Configuration menu according to the lens you are using so that distortion correction is performed correctly.

ELPLS04, ELPLU02, ELPLR04, ELPLW04, ELPLM06, ELPLM07, ELPLL07

☛ **Extended - Operation - Advanced - Lens Type** [p.143](#)

- In a normal installation, the image may be tilted depending on your lens. Adjust the tilt of the image using the feet.
☛ "Adjusting the Tilt (for Normal Installment)" [p.46](#)
- Depending on the lens you are using, there may be a visible misalignment in color pixels. Adjust the image using Panel Alignment.
☛ "Panel Alignment" [p.44](#)
- For information on installing ELPLX02/ELPLX02W, see the User's Guide supplied with ELPLX02/ELPLX02W.

- 1** Loosen the lens cover fixing screw.
Turn the screw by hand.

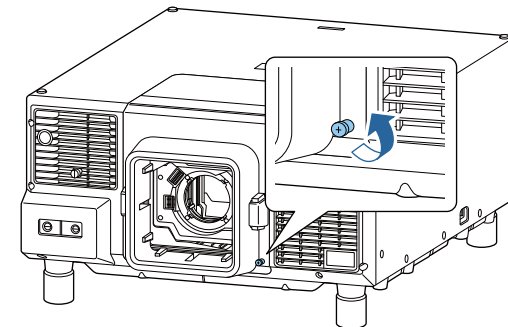

- 2** While pressing the top and bottom buttons on both sides of the lens replacement cover, pull it towards you to remove it.

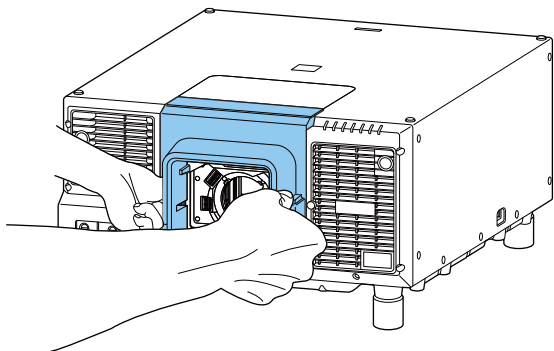

When using ELPLX02/ELPLX02W, loosen the fixing screw on the lens replacement cover on the top of the projector, and then pull the cover towards you to remove it.

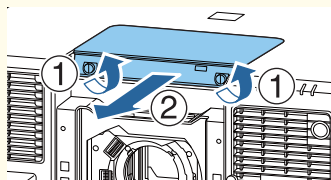

- 3** Release the lock if the lever is locked. Pull up the lever lock, move it to the left, and then push it back in.

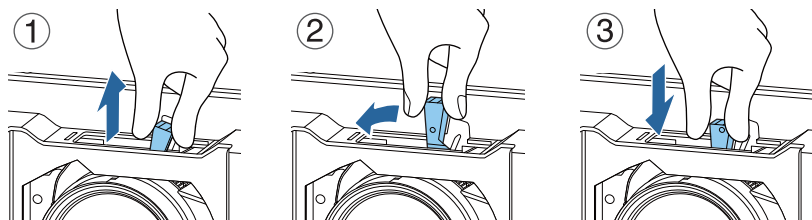

- 4** Pinch the lever, and then move it counter-clockwise.

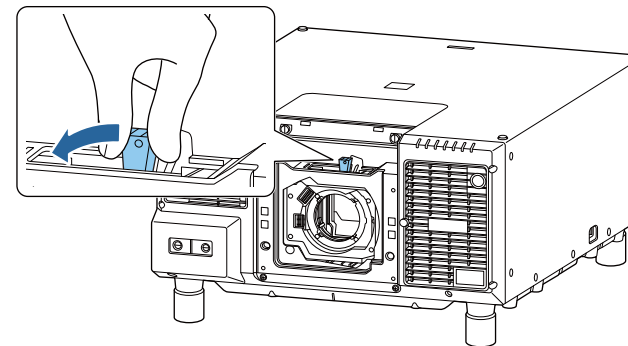

When using the following lenses, make sure you attach the lens connector cap supplied to protect the ports.

ELPLS04, ELPLU02, ELPLR04, ELPLW04, ELPLM06, ELPLM07, ELPLL07

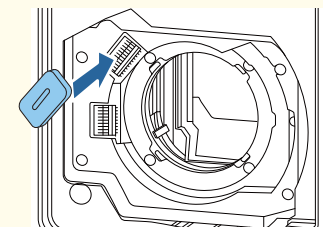

- 5** Insert the lens unit straight into the lens insertion section with the white circle on the lens on top.

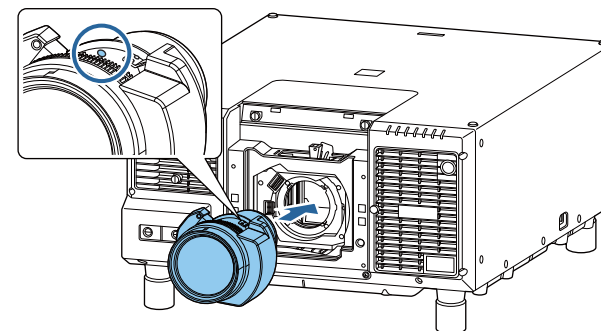

- 6** While holding the lens unit firmly, move the lever clockwise to lock it.

Check that the lens cannot be detached.

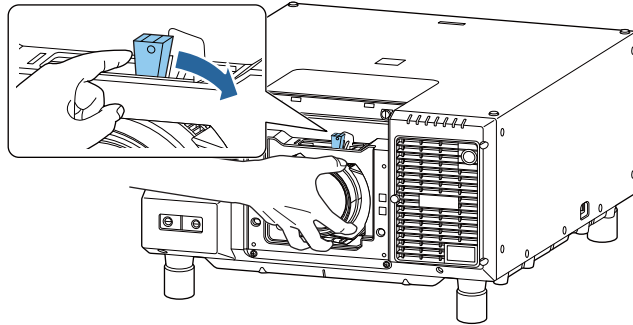

- 7** Secure the lever with the lever lock to make sure it does not come loose.

Pull up the lever lock, move it to the right, and then push it back in.

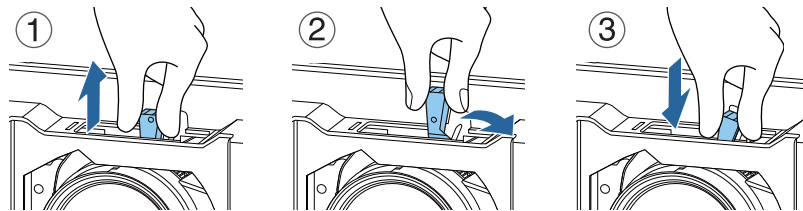

The lever is secured even without using the lever lock, but this adds an additional measure of safety.

- 8** Attach the lens replacement cover.

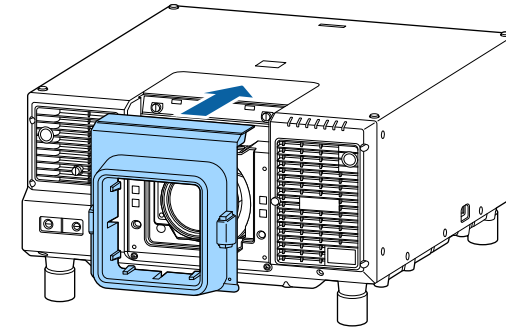

- 9** Tighten the lens cover fixing screw.

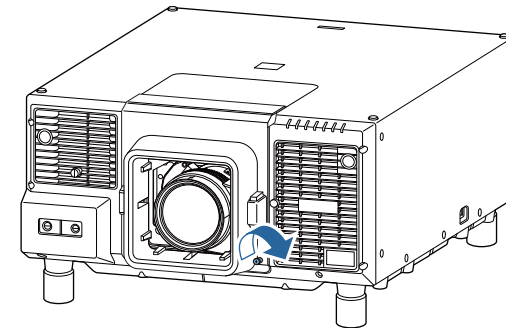

Lens Calibration

After replacing the lens unit, calibrate the lens so that the projector can correctly acquire the lens position and adjustment range.

After attaching a different lens unit from the previous one, a message is displayed when the projector is turned on.

Select **Yes** to calibrate the lens.

Lens calibration time varies depending on the lens. Depending on the lens, this can take up to three minutes. When it is complete, the lens returns to the position before the calibration (ELPLX02/ELPLX02W returns to the home position).

Attention

If the message "Lens Calibration failed." is displayed, remove the lens unit and then reinstall it. If the message continues to be displayed, stop using the projector, remove the power plug from the electrical outlet, and contact your local dealer or the nearest address provided in the Epson Projector Contact List.

☞ [Epson Projector Contact List](#)



- Use one of the following methods to perform lens calibration.
 - Press the [Calibration] button on the remote control or the control panel.
 - Hold down the [Default] button on the remote control for at least three seconds.
 - Configuration Menu
 - ☞ **Extended - Operation - Lens Calibration** [p.143](#)
- If no message is displayed after attaching the lens unit, perform lens calibration from the Configuration menu.
- If you do not calibrate the lens, the following functions may not operate correctly.
 - Lens Shift
 - Memory (Lens Position)
 - Zoom
 - Focus
 - Distortion

Removing



Caution

Wait for a while after turning off the projector before removing the lens unit (approximately 30 mins.). Touching the lens unit immediately after projecting or turning off may cause burns.

Attention

If you have used lens shift to move the lens position, move the lens to the home position and then replace the lens unit.

☞ "Adjusting the Position of the Projected Image (Lens Shift Adjustment)" [p.38](#)



The projector uses a laser as the light source. As a safety measure, the light source turns off when the lens is removed. Attach the lens, and then press the [ⓘ] button to turn it back on.

1

Loosen the lens cover fixing screw.

Turn the screw by hand.

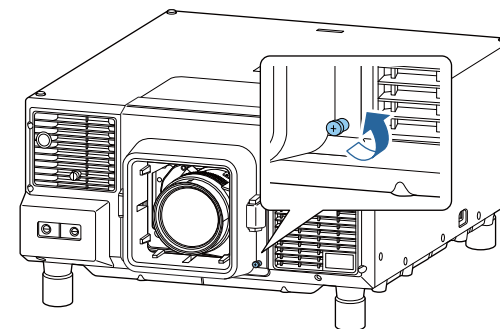

2

While pressing the top and bottom buttons on both sides of the lens replacement cover, pull it towards you to remove it.

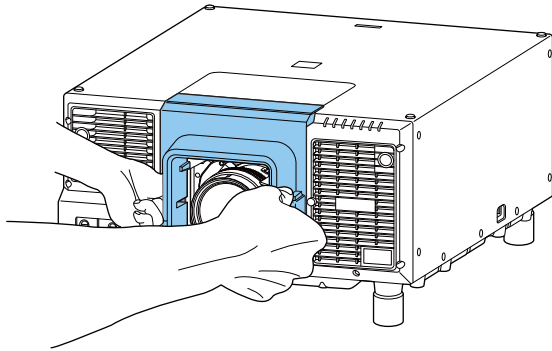

- 3** Release the lock if the lever is locked.
Pull up the lever lock, move it to the left, and then push it back in.

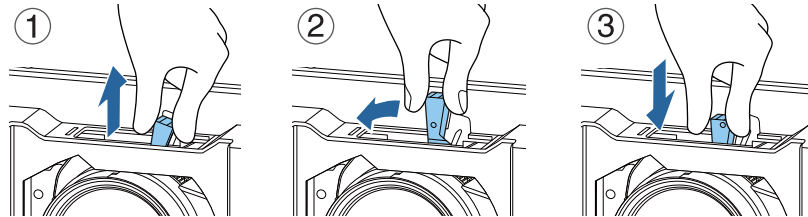

- 4** While holding the lens unit firmly, hold the lever and turn it counterclockwise to unlock the lens unit.
Pull the lens unit straight out as it is released.

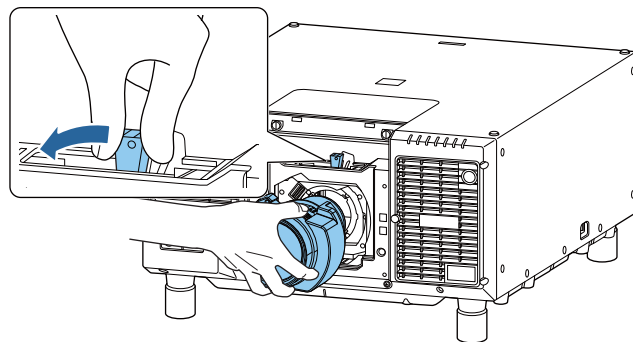

Installation Settings

Changing the direction of the image (projection mode)

You can change the direction of the image using **Projection** mode from the Configuration menu.

☛ **Extended - Projection** [p.143](#)

When Front is the standard, the image directions for each projection mode are as follows.

Front (default)



Rear

Front/Ceiling



Rear/Ceiling





- You can change the setting as follows by pressing down the [Shutter] button on the remote control for about five seconds.

Front ↔ Front/Ceiling

Rear ↔ Rear/Ceiling

- To rotate the menu display, set **OSD Rotation** in the Configuration menu.

 **Extended - Display - OSD Rotation** p.143

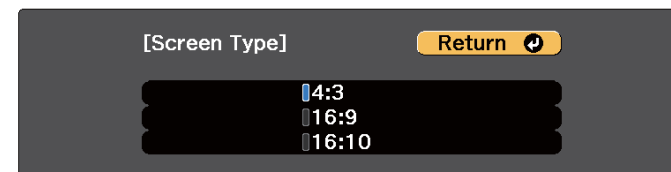

[Esc] / [⏪]:Return [⏩]:Select [Menu]:Exit



The shape of the background test pattern changes depending on the setting.

Screen Settings

Set the Screen Type according to the aspect ratio of the screen being used.

The area where the image is displayed matches the shape of the screen.



- The setting for the **Screen Type** at the time of purchase is **16:9**.
- This setting is fixed at **16:9** when **Link Type** is set to **Dual (3840x2160)** or **Dual (1920x2160 Split Screen)** in **DisplayPort Settings**.

1 Press the [Menu] button while projecting.
 "Configuration Menu Operations" p.132

2 Select **Display** from **Extended**.

3 Select **Screen Type** from **Screen**.

4 Select the screen's aspect ratio.

5 Press the [Menu] button to finish making settings.



- When you change the Screen Type, adjust the aspect ratio for the projected image as well.
 "Changing the Aspect Ratio of the Projected Image" p.80
- This function is not supported by the Message Broadcasting feature in Epson Projector Management.

Adjusting the position of the image on the projected screen

You can adjust the position of the image if there are margins between the edge of the image and the projected screen frame due to the Screen Type setting.

Example: When the **Screen Type** is set to 4:3



You can move the image to the left and right.

- 1 Press the [Menu] button while projecting.
 ☛ "Configuration Menu Operations" p.132
- 2 Select **Display** from **Extended**.
- 3 Select **Screen Position** from **Screen**.
- 4 Use the [▲], [▼], [◀], and [▶] buttons to adjust the position of the image.

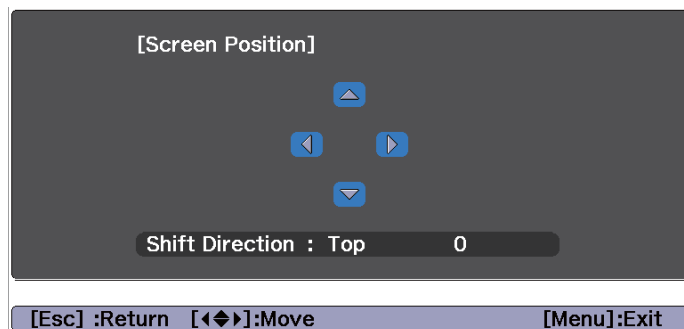

You can check the current display position by using the background test pattern.

- 5 Press the [Menu] button to finish making settings.



When the **Screen Type** is set to **16:9**, the **Screen Position** cannot be adjusted.

Displaying the Test Pattern

A test pattern can be displayed to adjust the projection status without connecting video equipment.

The shape of a test pattern is according to the setting of **Screen Type**. Set **Screen Type** first.

☛ "Screen Settings" p.36

- 1 Press the [Test Pattern] button of the remote control or the control panel while projecting.
- 2 You can switch test patterns by pressing the [↑][↓] buttons on the remote control or the [↵] button on the control panel while a test pattern is displayed.

Using the remote control

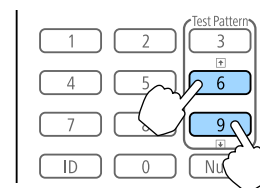

Using the control panel

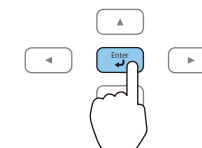

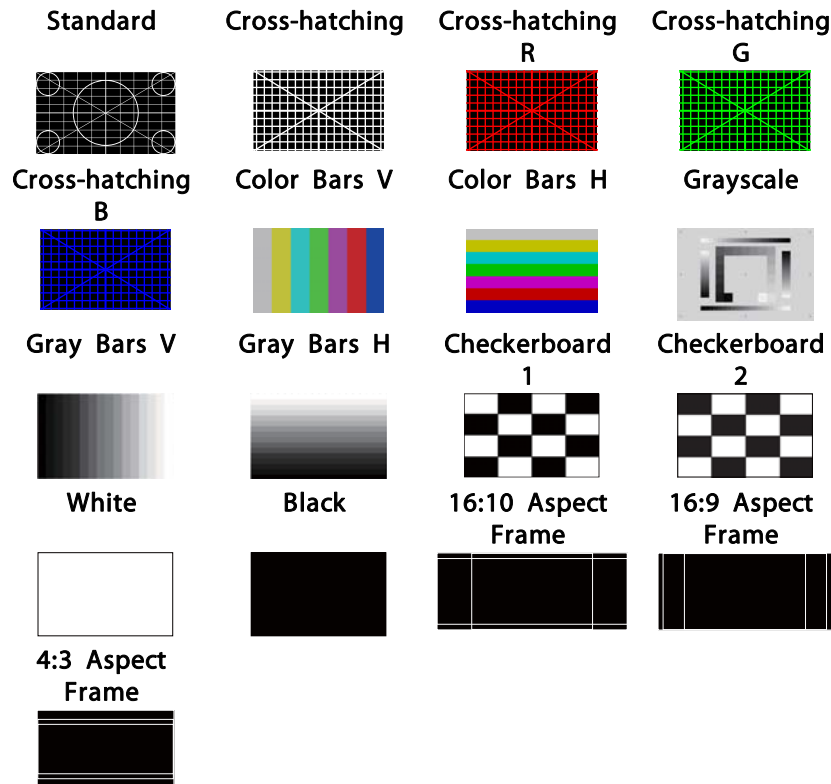

- To set menu items that cannot be set while the test pattern is being displayed or to fine-tune the projected image, project an image from the connected device.
- You can also select a test pattern from the Configuration menu.
 - Settings - Test Pattern [p.141](#)

3 Press the [Esc] button to close the test pattern.

Adjusting the Position of the Projected Image (Lens Shift Adjustment)

The lens can be shifted to adjust the position of the projected image, for example, when the projector cannot be installed directly in front of the screen.

The ranges within which the image can be moved are shown below. The position of the projected image cannot be moved to both the horizontal and vertical maximum values.

When using ELPLU03/ELPLU03S/ELPLW05

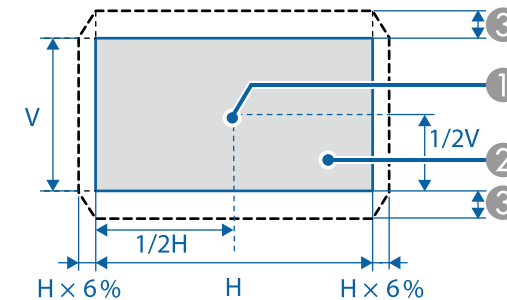

- Center of lens
- Projected image when the lens position is moved to the home position
- Maximum motion range*: $V \times 18\%$

* When the horizontal direction is at the maximum value, the image cannot be moved up or down.

When using the ELPLU04/ELPLW06/ELPLW08/ELPLM09/ELPLM10/
ELPLM11/ELPLM15/ELPLL08

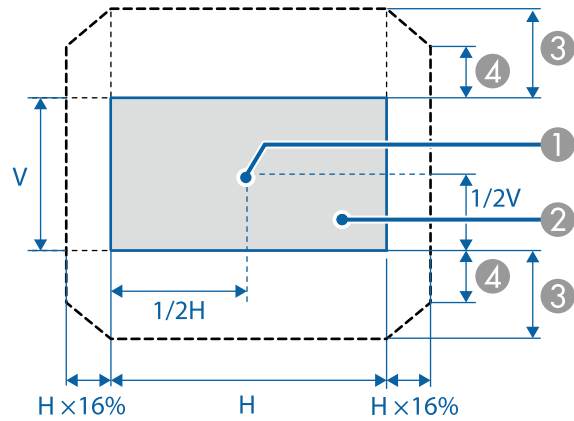

- ① Center of lens
- ② Projected image when the lens position is moved to the home position
- ③ Maximum motion range: $V \times 58\%$
- ④ Horizontal direction at maximum value: $V \times 34\%$

When using the ELPLX02/ELPLX02W

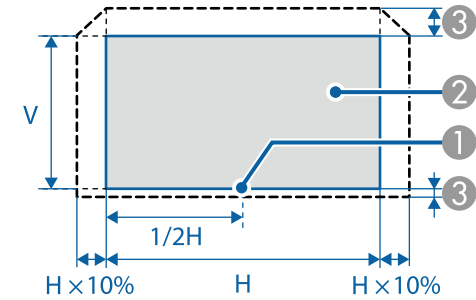

- ① Center of lens
 - ② Projected image when the lens position is moved to the home position
 - ③ Maximum motion range*: Up $V \times 18\%$, Down $V \times 5\%$
- * When the horizontal direction is at the maximum value, the image cannot be moved upward.



- When adjusting the image height with the vertical lens shift, adjust by moving the image from the bottom to the top. If it is adjusted from the top to the bottom, the image position may move down slightly after adjusting.
- We recommend setting the focus, zoom, and lens shift at least 30 minutes after you start the projection, because images are not stable right after turning on the projector.
- The image will be clearest when the lens position is moved to the home position.
- If you hold down the [Lens Shift] button on the remote control or the control panel for at least three seconds, the lens position moves to the home position.
- If you set **A/V Output** to **Always On**, you can move the lens position to the home position even if the projector is in standby mode.
 ➔ **Extended - A/V Settings - A/V Output p.143**
- Lens shift is not available for the ELPLR04.

1 Press the [Lens Shift] button on the remote control or the control panel.

Using the remote control

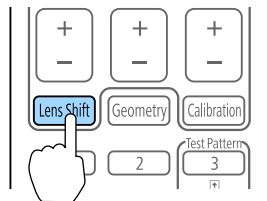

Using the control panel

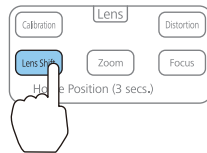

2 Press the [▲][▼][◀][▶] buttons to adjust the position of the projected image.

Using the remote control

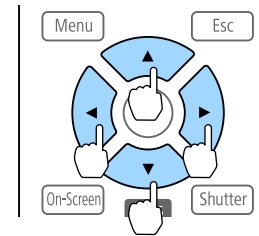

Using the control panel

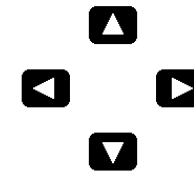
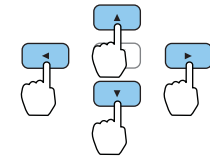

The displayed screen may differ depending on your lens.

3 Press the [Esc] button to finish the adjustment.

Adjusting the Image Size



This is not available for the ELPLR04.

- 1 Press the [Zoom] button on the control panel.

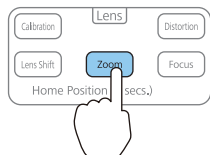

- 2 Press the [◀][▶] buttons to adjust.

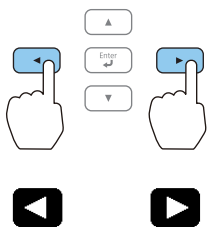

The displayed screen may differ depending on your lens.

- 3 Press the [Esc] button to finish the adjustment.



You can also use the [Zoom] buttons [+][-] on the remote control to adjust the size of the image.

Correcting the Focus

- 1 Press the [Focus] button on the control panel.

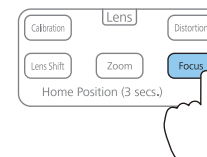

- 2 Press the [◀][▶] buttons to adjust.

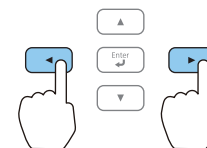

The displayed screen may differ depending on your lens.



When using the following lens, a message prompting you to adjust the distortion (image warping) is displayed. After adjusting the focus, adjust the distortion.

ELPLX02, ELPLX02W, ELPLU02, ELPLU03, ELPLU03S,
ELPLU04, ELPLW05, ELPLW08

☞ "Correcting Distortion (Image Warping)" [p.42](#)

- 3 Press the [Esc] button to finish the adjustment.



- You can also use the [Focus] buttons, [+] and [-] on the remote control to adjust the focus. You can also use the [▲][▼] buttons on the remote control or the control panel while the lens calibration screen is displayed.
- When projecting from several projectors and there is a difference in brightness, we recommend displaying the grayscale test pattern and adjusting the focus.
 - ☛ "Displaying the Test Pattern" p.37
- If the focus is not correct even after adjusting the focus, press the [Calibration] button on the remote control to perform lens calibration. When lens calibration is complete, adjust the focus again.

Correcting Distortion (Image Warping)

When using a short throw zoom lens and focusing at the center of the screen, the surrounding image may warp and be out of focus. Follow the steps below to correct the warping.

- 1** Press the [Focus] button on the control panel.
- 2** Press the [◀][▶] buttons to focus the image around the center of the lens.

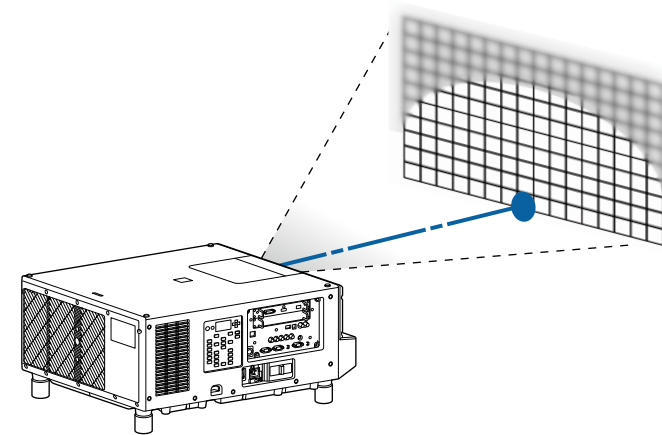

- 3** Press the [Distortion] button on the control panel.

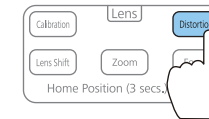

- 4** Press the [◀][▶] button to adjust the focus of the surrounding area.

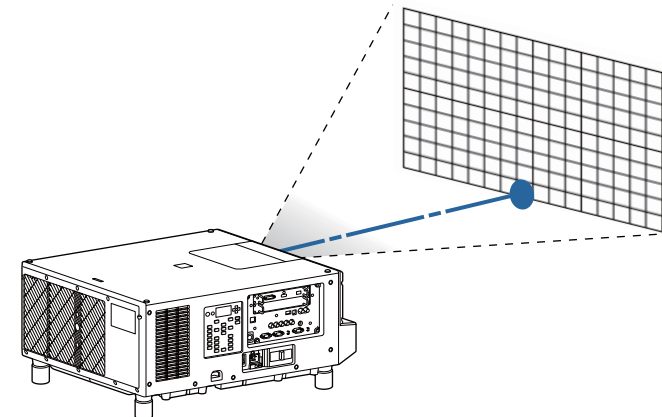

If the center is out of focus after adjusting the surrounding image, repeat steps 1 to 2.



- Depending on the lens you are using, there may be a visible misalignment in color pixels. Adjust the color misalignments using Panel Alignment.
 "Panel Alignment" [p.44](#)
- You can also adjust distortion in images using the remote control. After adjusting the focus at the center of the lens using the [Focus] buttons, [+] and [-], use the [Distortion] buttons, [+] and [-] to adjust the surrounding image.
- When using the ELPLU02, a message prompting you to manually adjust the distortion is displayed. Turn the distortion ring counterclockwise, and then adjust the focus. After adjusting the focus, turn the distortion ring manually to correct the image distortion.

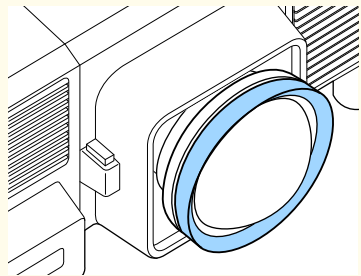

Registering and Loading Lens Adjustment Values

You can register a lens position whose lens shift, zoom, focus, and distortion was adjusted in memory, and load it when necessary. You can register up to 10 values.



- This cannot be used when the following lenses are attached. ELPLS04, ELPLU02, ELPLR04, ELPLW04, ELPLM06, ELPLM07, ELPLL07
- If you did not calibrate your lens, a message is displayed when you save a memory. Select **Yes** to calibrate the lens.
- The lens position when a memory is loaded may not completely match the lens position when the memory was saved.
- If there is a large discrepancy between the lens position when a memory is loaded and the lens position when the memory was saved, calibrate the lens.
 **Extended - Operation - Lens Calibration** [p.143](#)

1 Press the [Memory] button while projecting.

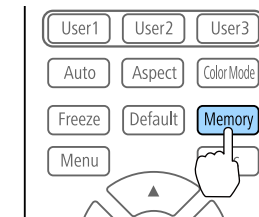

- You can also operate from the Configuration menu.
 **Settings - Memory** [p.141](#)

2 Select **Lens Position**, and then press the [**↵**] button.

3 Select the function you want to perform, then press the [**↵**] button.

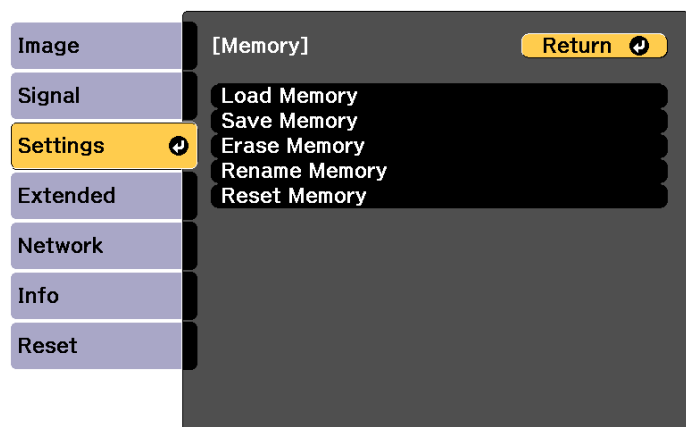

[Esc] / [Return]:Return [Left Arrow]:Select [Menu]:Exit

Function	Explanation
Load Memory	Loads the saved memory. When you select a memory name and press the [Left Arrow] button, the lens is automatically adjusted according to the settings of the selected memory.
Save Memory	Registers current settings in the memory. When you select a memory name and press the [Left Arrow] button, the settings are saved.
Erase Memory	Erases the registered memory. When you select a memory name and press the [Left Arrow] button, a message is displayed. Select Yes , and then press the [Left Arrow] button to erase the selected memory.
Rename Memory	Changes the memory name. Select the memory name you want to change, and then press the [Left Arrow] button. Enter the memory name using the soft keyboard.  "Soft keyboard operations" p.150 When you have finished, move the cursor over Finish , and then press the [Left Arrow] button.

Function	Explanation
Reset Memory	Resets the name and settings of a saved memory.



If the mark on the left of the memory name is turned blue, it means the memory has already been registered. When you select a registered memory, a message is displayed asking you to confirm that you want to overwrite the memory. If you select **Yes**, the previous settings are deleted and the current settings are registered.

Panel Alignment

Adjusts the pixel color shift for the LCD panel. You can adjust the pixels horizontally and vertically by 0.125 pixel within a range of ± 3 pixel.



Image quality may decline after performing LCD alignment.

- 1** Press the [Menu] button while projecting.
- 2** Select **Display** from **Extended**.
- 3** Select **Panel Alignment**, and then press the [Left Arrow] button.

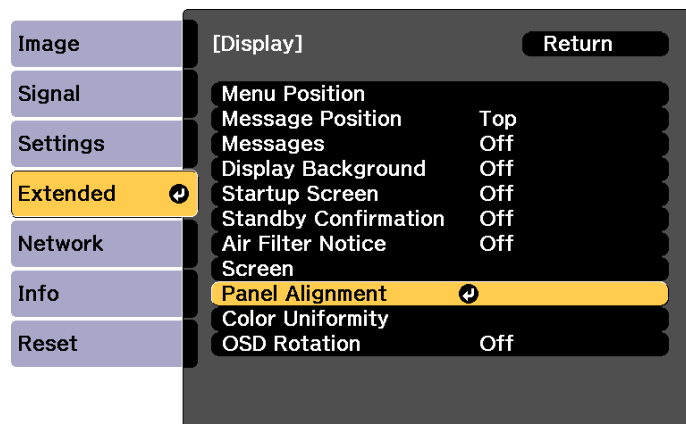

[Esc]:Return [↩]:Select [↵]:Enter [Menu]:Exit

4 Enable **Panel Alignment**.

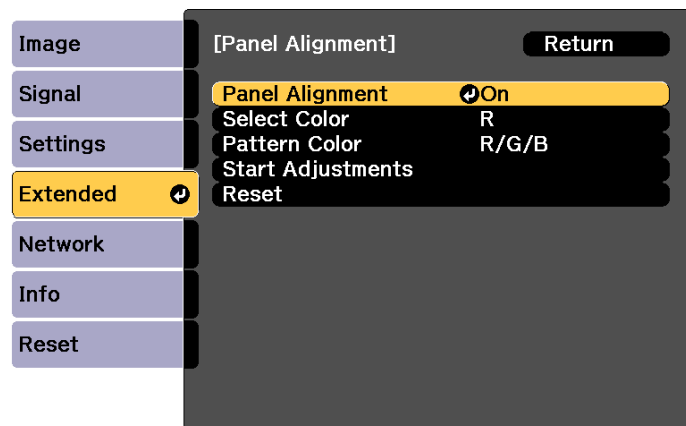

[Esc]:Return [↩]:Select [↵]:Enter [Menu]:Exit

- (1) Select **Panel Alignment**, and then press the [↵] button.
- (2) Select **On**, and then press the [↵] button.
- (3) Press the [Esc] button to return to the previous screen.

5 Select the color you want to adjust.

- (1) Select **Select Color**, and then press the [↵] button.
- (2) Select **R** (red) or **B** (blue), and then press the [↵] button.
- (3) Press the [Esc] button to return to the previous screen.

6 Select the grid color displayed when making adjustments from **Pattern Color**.

- (1) Select **Pattern Color**, and then press the [↵] button.
- (2) Select a combination of R (red), G (green), and B (blue) for the grid color.
R/G/B: Displays a combination all three colors; red, green and blue. The actual color of the grid is white.
R/G: This is available when **R** is selected from **Select Color**. Displays a combination of two colors; red and green. The actual color of the grid is yellow.
G/B: This is available when **B** is selected from **Select Color**. Displays a combination of two colors; green and blue. The actual color of the grid is cyan.
- (3) Press the [Esc] button to return to the previous screen.

7 Select **Start Adjustments**, and then press the [↵] button.

First, select **Shift the whole panel** to adjust the entire LCD panel. When the start confirmation message is displayed, press the [↵] button to start adjustment.



The image may become distorted while adjusting. The image is restored once adjustments are complete.

8 Use the [▲][▼][◀][▶] buttons to make adjustments, and then press the [↵] button.

9 To perform more detailed adjustments, select **Adjust the four corners**, and then press the [↵] button to confirm.

10 Use the [▲], [▼], [◀], and [▶] buttons to make adjustments, and then press the [↵] button to move to the next adjustment point.

11 When you have adjusted all four corners, select **Exit**, and then press the [↵] button.

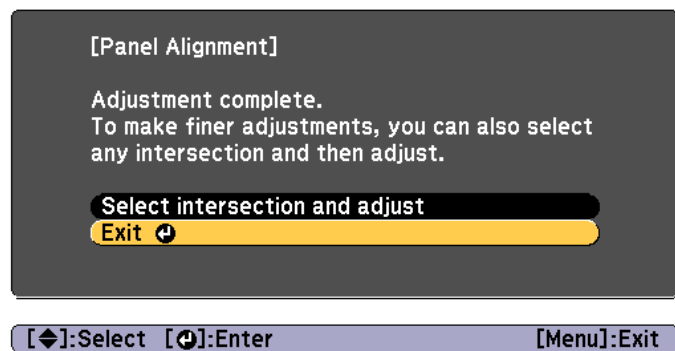

If you feel you still need to make adjustments after correcting all four points, select **Select intersection and adjust** and then continue making adjustments.

Adjusting the Tilt (for Normal Installment)

Extend and retract the feet to adjust the projector's horizontal and vertical tilt. You can adjust the tilt within a range of $\pm 2^\circ$.

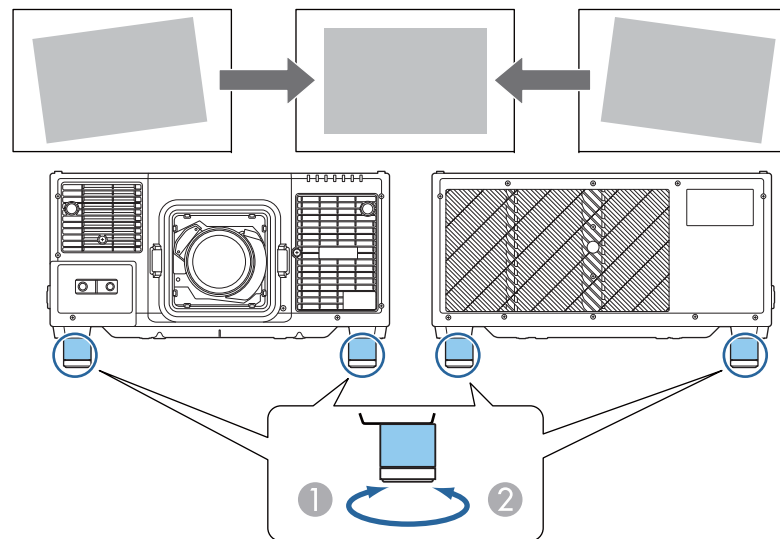

- ① Extend the feet.
- ② Retract the feet.

Attention

The feet are detachable. You can extend the feet by approximately 28 mm before they detach.

ID Settings

When an ID is set for the projector and the remote control, you can use the remote control to operate only the projector with a matching ID. This

is very useful when managing multiple projectors. You can set up to 30 IDs.



- Operation using the remote control is possible only for projectors that are within the operating range of the remote control.
 - ☛ "Remote control operating range" [p.28](#)
- IDs are ignored when the projector ID is set to **Off** or the remote control ID is set to **0**.
- If you use Epson Web Control, you can operate a specific projector from a mobile device.
 - ☛ "Changing Settings Using a Web Browser (Epson Web Control)" [p.214](#)

Set the projector ID

- 1 Press the [Menu] button while projecting.
 - ☛ "Configuration Menu Operations" [p.132](#)
- 2 Select **Multi-Projection** from **Extended**.
- 3 Select **Projector ID**, and then press the [↵] button.
- 4 Press the [◀][▶] buttons to select an ID number.

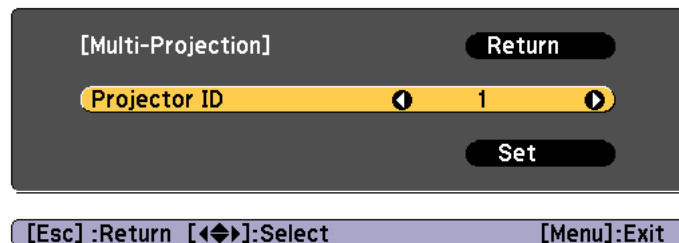

- 5 Select **Set**, and then press the [↵] button.

- 6 Press the [Menu] button to close the Configuration menu.

Checking the projector ID

During projection, press the [i] button while holding down the [ID] button on the remote control.

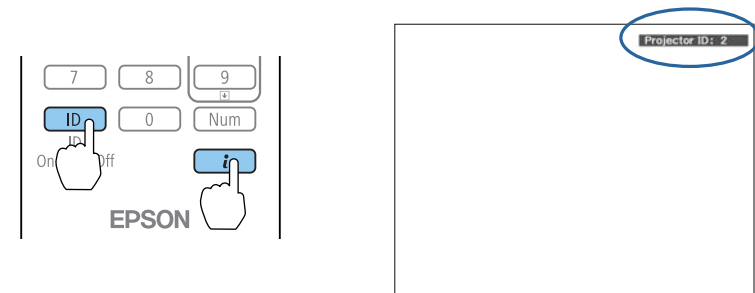

When you press the buttons, the current Projector ID is displayed on the projection screen. It disappears in about three seconds.

Setting the remote control ID

- 1 Set the remote control [ID] switch to On.

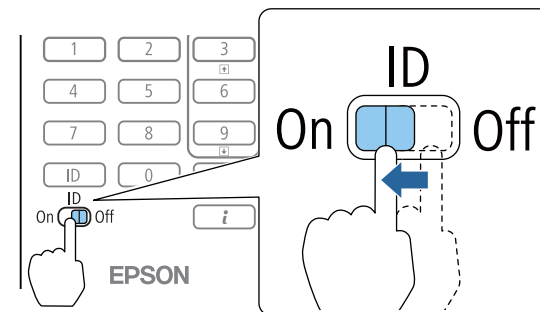

2 While holding the [ID] button, press a number button to select a number to match the ID of the projector you want to operate.

☛ "Checking the projector ID" [p.47](#)

Enter a two digit number (Example: 01 when the ID is 1).

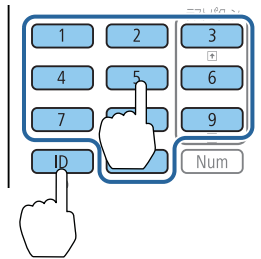

Once this setting has been made, the projector that can be operated by the remote control is limited.



The remote control ID setting is saved in the remote control. Even if the remote control batteries are removed to replace them and so on, the stored ID setting is retained. However, if the batteries are left out for a long time, it is reset to the default value (ID0).

Setting the Time

You can set the time for the projector. The set time is used for the schedule function.

☛ "Scheduling Function" [p.107](#)



- When you turn on the projector for the first time, the message "Do you want to set the time?" is displayed. When you select **Yes**, the screen from step 4 is displayed.
- When **Schedule Protection** is set to **On** in **Password Protection**, settings related to the date and time cannot be changed. You can make changes after setting **Schedule Protection** to **Off**.
 - ☛ "Managing Users (Password Protection)" [p.111](#)

- 1** Press the [Menu] button while projecting.
 - ☛ "Configuration Menu Operations" [p.132](#)
- 2** Select **Operation** from **Extended**.
- 3** Select **Date & Time**, and then press the [**↵**] button.
- 4** Make settings for the date and time.
 - Use the soft keyboard to enter the date and time.
 - ☛ "Soft keyboard operations" [p.150](#)

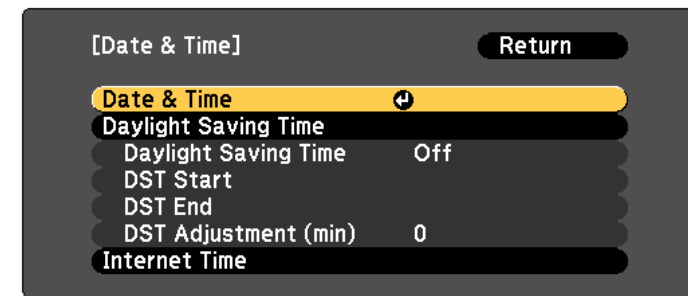

Date & Time

Submenu	Function
Date	Set today's date.
Time	Set the current time.

Submenu	Function
Time Difference (UTC)	Set the time difference from Coordinated Universal Time.
Settings	The settings made in Date & Time are applied.

Daylight Saving Time

Submenu	Function
Daylight Saving Time	Set whether or not (On/Off) to activate the daylight saving time. DST Adjustment (min) adjusts the time difference between the standard time and daylight saving time.
DST Start	Set the date and time to start the daylight saving time.
DST End	Set the date and time to end the daylight saving time.
Settings	The settings made in Daylight Saving Time are applied.

Internet Time

Submenu	Function
Internet Time	Set to On to update the time automatically through an Internet time server.
Internet Time Server	Input the IP address for an Internet time server.
Settings	The settings made in Internet Time are applied.





When changing settings, make sure you select **Set**, and then press the [**↵**] button.

5 Press the [Menu] button to finish making settings.

Other Settings

Settings related to basic operations

Purpose	Setting Methods
To start/stop projection by turning on/off the main power switch or plugging in or unplugging the power plug of the projector.	<ul style="list-style-type: none"> When Direct Power On is set to On, the projector can start projecting when power is supplied. (Default value: Off)  Extended - Operation - Direct Power On p.143 The projector can be powered off directly by the breaker because it supports the direct shutdown function.
To disable buzzer beeps generated when the projector is powered on/off.	Set Beep to Off . (Default value: On)  Extended - Operation - Advanced - Beep p.143
Turn off the power by pressing the [⏻] button once.	Set Standby Confirmation to Off . (Default value: On)  Extended - Display - Standby Confirmation p.143

Settings related to display

Purpose	Setting Methods
To change the menu position.	Change the settings of Menu Position . ☛ Extended - Display - Menu Position p.143
To change the menu direction.	Change the settings of OSD Rotation . ☛ Extended - Display - OSD Rotation p.143
To prevent the display of menus, messages, or warnings on the screen.	Each time you press the [On-Screen] button on the remote control, menus or messages and so on are shown or hidden. While menus are hidden, you cannot operate the Configuration menu (except switching the color mode and input source).
To disable the display of the message on the projection screen when switching the source.	Set Messages to Off . (Default value: On) ☛ Extended - Display - Messages p.143 You can confirm warning by the display of the indicator. ☛ "Reading the Indicators" p.171 Dialogs related to operations and behaviors, laser warnings, termination of Message Broadcasting for the Epson Projector Management, and projector ID are displayed.
To register and save the settings of the projected image.	Set Memory . ☛ "Memory Function" p.105 You can save the following settings. <ul style="list-style-type: none"> • Memory: Some settings in the Configuration menu • Lens Position: Adjustment values of the lens shift, zoom, focus, and distortion • Geometry Correction: Adjustment value of the geometry correction

Purpose	Setting Methods
To change the screen displayed on the background.	Change from Display . You can select from blue, black, and logo. If no logo is registered, the EPSON logo is displayed. Display Background : Set the screen display with no image signal input. (Default value: Blue) ☛ Extended - Display - Display Background p.143 Startup Screen : Set whether or not (On/Off) to display the user logo when the projector is turned on. (Default value: On) ☛ Extended - Display - Startup Screen p.143
To turn off the LCD display or control panel buttons	Set Lighting Time to Off on the LCD display. ☛ "Setting the screen display (LCD)" p.180

The port name, location, and connector orientation differ depending on the source being connected.

Connecting a Computer

To project images from a computer, connect the computer using one of the following methods.

- 1 When using a commercially available computer cable**
Connect the computer's display output port to the projector's Computer In port.
- 2 When using a commercially available HDMI cable**
Connect the computer's HDMI port to the projector's HDMI In port.
- 3 When using a commercially available DVI-D cable**
Connect the computer's DVI-D port to the projector's DVI-D In port.
- 4 When using a commercially available DisplayPort cable (When installing an optional DisplayPort interface board)**
Connect the computer's DisplayPort port to the projector's DisplayPort In port.

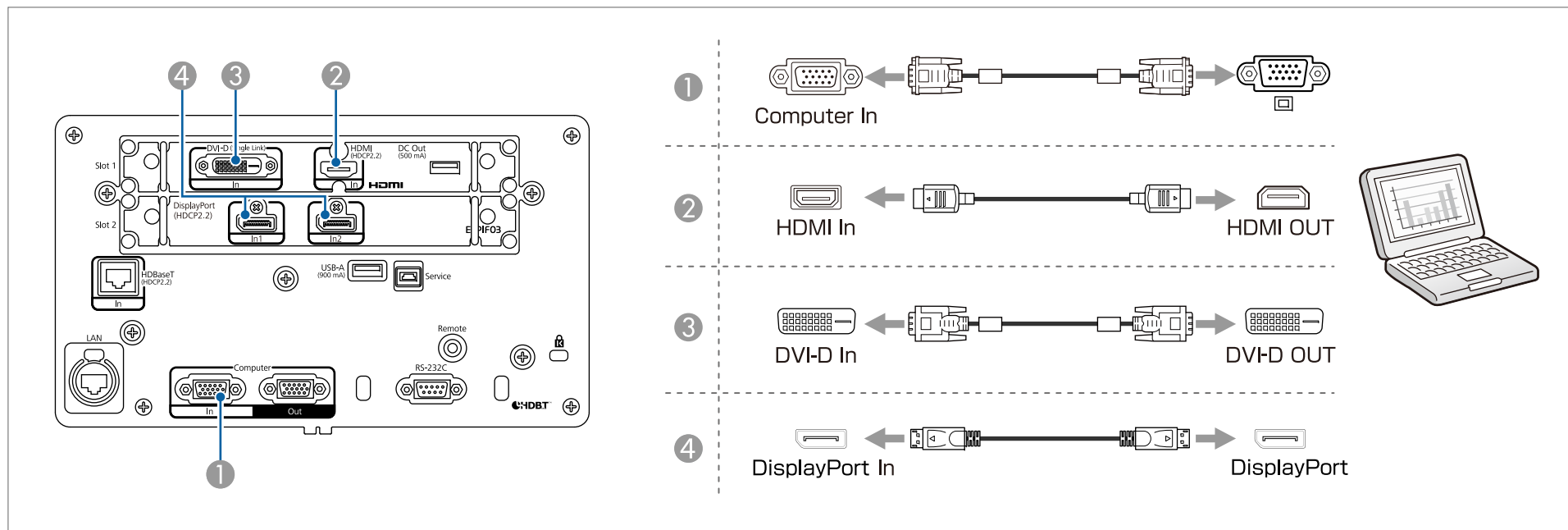



- If the source you want to connect to has an unusually shaped port, use the cable supplied with the device or an optional cable to connect to the projector.
- Make sure the HDMI cable conforms to the HDMI standard. If you use a cable that does not conform to the HDMI standard, images may not be displayed correctly.
- When sending 4K60 4:4:4 18 Gbps images, use a premium HDMI cable. If you use an incompatible cable, images may not be displayed correctly. If images are not displayed at 18 Gbps, you may be able to display them by lowering the **Resolution** setting in **EDID** from the **Signal** menu.
 - ☛ **Signal - Advanced - EDID** [p.138](#)
- When using the power port for an optical HDMI cable, connect it to the DC Out port.
- Images may not be displayed correctly depending on the length and performance quality of the HDMI cable.
- Make sure the cable you are using is as short as possible. Images may not display correctly when using a long cable.
- When connecting two cables to the DisplayPort1 In and DisplayPort2 In ports and inputting a signal, connect directly with a cable of the same type and length (DP1.2 or more). Images may not be displayed correctly when connecting using a docking station and so on.
- You can set the signal from the DisplayPort port in **DisplayPort Settings**.
 - ☛ **Extended - DisplayPort Settings** [p.143](#)
- When connecting two cables to the DisplayPort1 In and DisplayPort2 In ports and inputting a signal, set the **Link Type** in **DisplayPort Settings** on the projector first, and then make the graphics board output settings.
 - ☛ **Extended - DisplayPort Settings - Link Type** [p.143](#)
- When connecting two cables to the DisplayPort1 In and DisplayPort2 In ports and projecting the input signal, do not disconnect either of the cables during projection. If you do disconnect a cable, re-connect it and then restart the projector.

Connecting Image Sources

To project video images, connect to the projector using one of the following methods.

- 1 **When using a commercially available component video cable (D-sub/component converter)**
Connect the component output port on the video equipment to the projector's Computer In port.
- 2 **When using a commercially available BNC video cable (SDI input)**
Connect the SDI port on the video equipment to the projector's SDI In port.
- 3 **When using a commercially available HDMI cable**
Connect the HDMI port on the video equipment to the projector's HDMI In port.

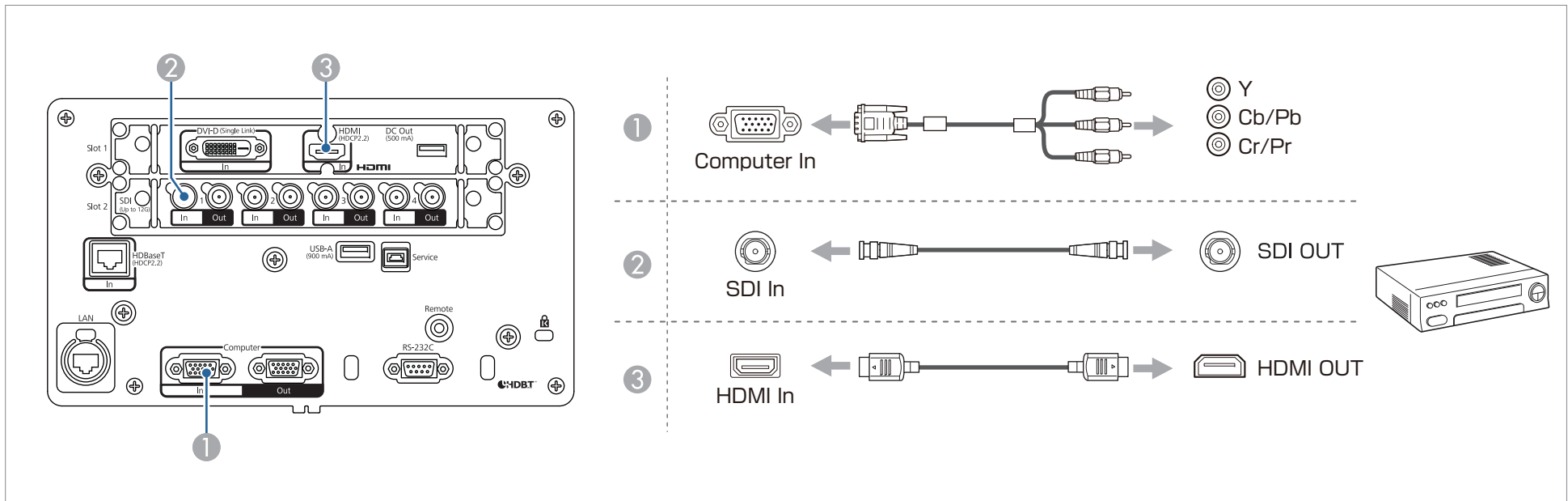

Attention

- If the input source is on when you connect it to the projector, it could cause a malfunction.
- If the orientation or shape of the plug differs, do not try to force it in. The device could be damaged or could malfunction.



- If the source you want to connect to has an unusually shaped port, use the cable supplied with the device or an optional cable to connect to the projector.
- Make sure the HDMI cable conforms to the HDMI standard. If you use a cable that does not conform to the HDMI standard, images may not be displayed correctly.
- When sending 4K60 4:4:4 18 Gbps images, use a premium HDMI cable. If you use an incompatible cable, images may not be displayed correctly. If images are not displayed at 18 Gbps, you may be able to display them by lowering the **Resolution** setting in **EDID** from the **Signal** menu.
 - ☛ **Signal - Advanced - EDID** [p.138](#)
- When using the power port for an optical HDMI cable, connect it to the DC Out port.
- Images may not be displayed correctly depending on the length and performance quality of the HDMI cable.
- When inputting a quad-link 3G-SDI signal, connect the video equipment to the SDI1 In to SDI4 In ports using 5C-FB or higher cables of the same type and length.
- When inputting a 12G-SDI signal, connect using a 5.5 CUHD or higher cable.
- Make sure the cable you are using is as short as possible. Images may not display correctly when using a long cable.
- You can set the signal from the SDI In port in **SDI Settings**.
 - ☛ **Extended - SDI Settings** [p.143](#)
- When inputting a quad-link signal, set the **Link Type** in **SDI Settings** on the projector first, and then make the video equipment output settings.
 - ☛ **Extended - SDI Settings - Link Type** [p.143](#)

Connecting to an External Monitor

You can output images to an external monitor.

- ① **When you want to output images from equipment connected to the Computer In port**
Connect the D-Sub port on the external monitor to the Computer Out port on the projector.
- ② **When you want to output images from equipment connected to the SDI In port**
Connect the SDI input port on the external monitor to the SDI Out port on the projector.

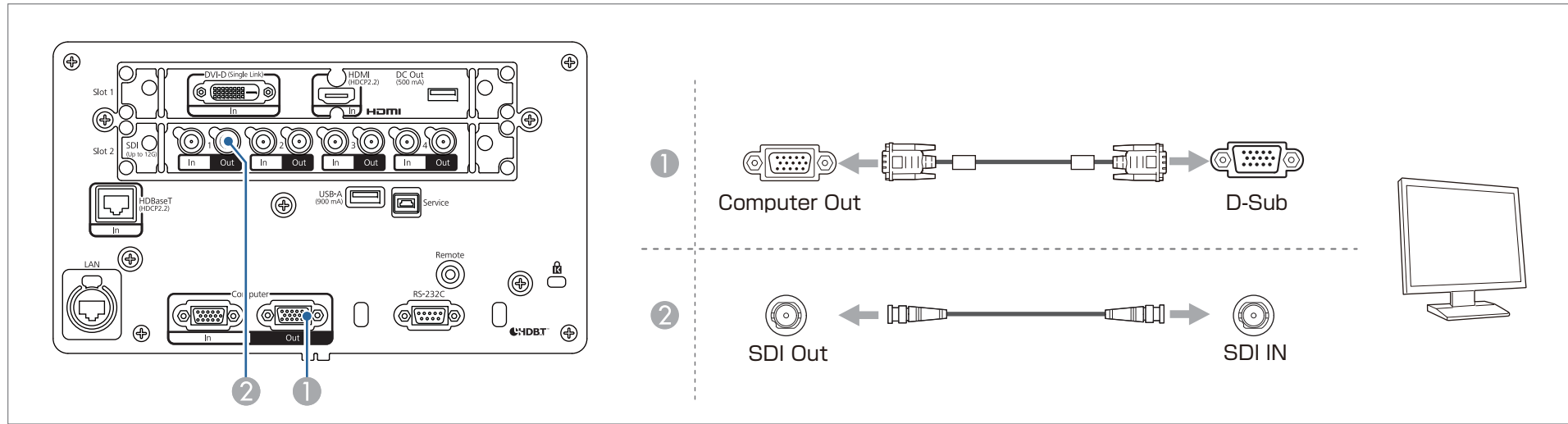

 No images are input when the projector is in standby mode.

Connecting a LAN Cable

Connect a LAN port on network hubs or other equipment to the projector's LAN port with a commercially available 100BASE-TX or 10BASE-T LAN cable. Commercially available etherCON LAN cables are also supported.

By connecting a computer to the projector over a network, you can project images and check the status of the projector.

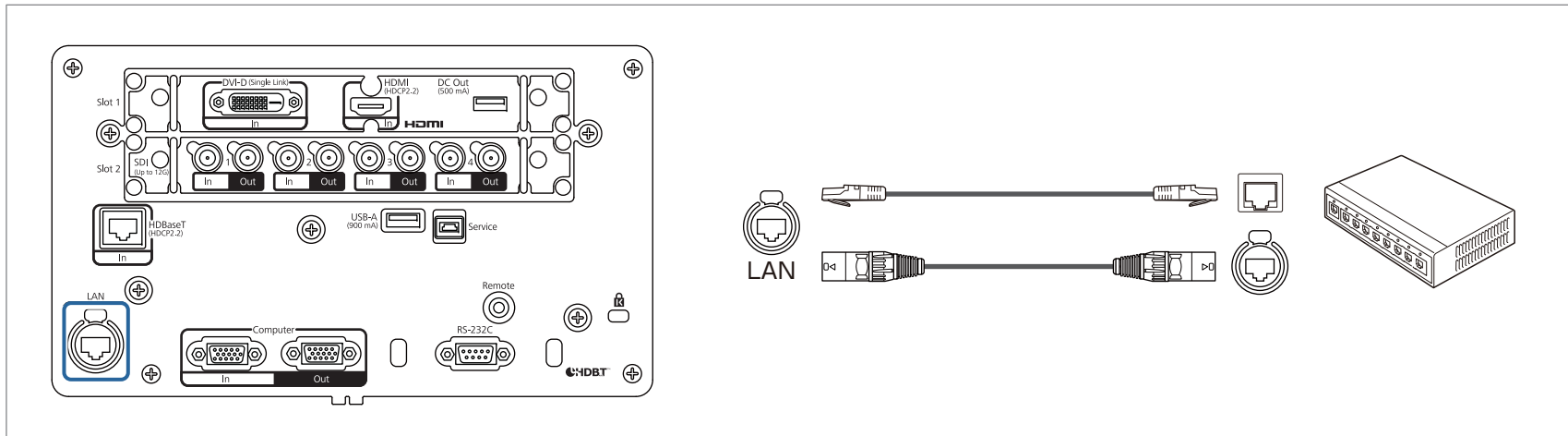

To prevent malfunctions, use a category 5 or higher shielded LAN cable.

Connecting an HDBaseT Transmitter

Connect the optional HDBaseT Transmitter with a commercially available 100BASE-TX LAN cable.

☛ "Optional Accessories" [p.236](#)

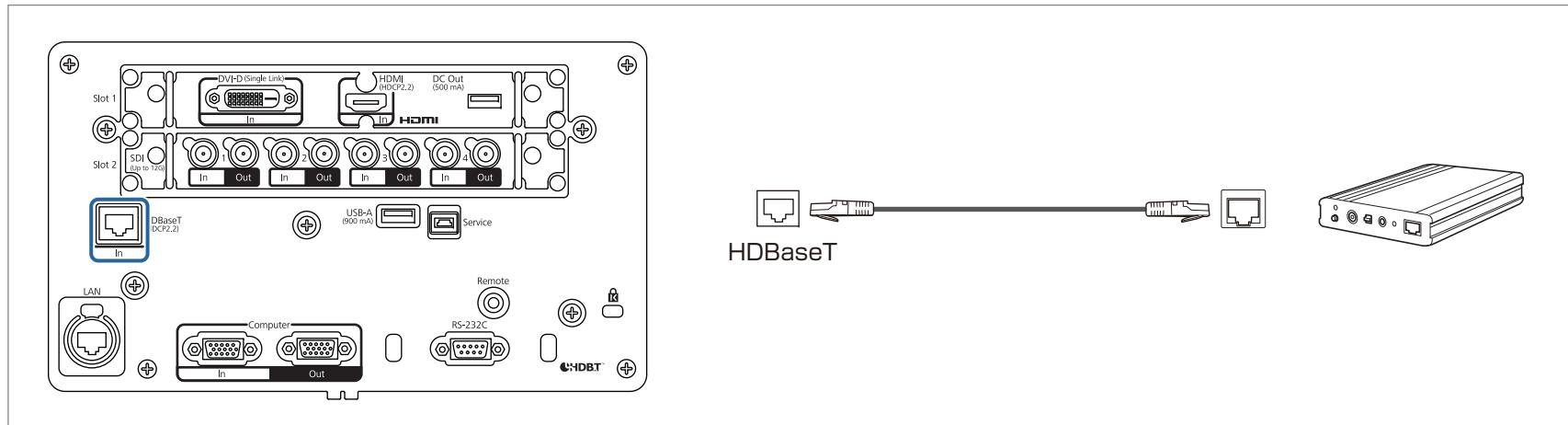

- Make sure you read the User's Guide supplied with the HDBaseT Transmitter carefully before use.
- For the LAN cable, use an HDBaseT Alliance-recommended STP cable (straight) of category 6 or higher. However, operation is not guaranteed for all input/output devices and environments.
- When connecting or disconnecting the LAN cable, make sure you turn off the power for the projector and the HDBaseT Transmitter.
- When performing Ethernet communication or serial communication, or when using the wired remote control via HDBaseT port, set **Control Communications** to **On** from the Configuration menu.
 - ☛ **Extended - HDBaseT - Control Communications** [p.143](#)

Note that when **Control Communications** is set to **On**, the projector's LAN port, RS-232C port, and Remote port are disabled.
- When using the Extron XTP transmitter or switcher, connect to the projector's HDBaseT port. Set **Extron XTP** to **On** (**Standby Mode** and **Control Communications** are automatically set to **On**).
 - ☛ **Extended - HDBaseT - Extron XTP** [p.143](#)
- You can check the status of the signal being input to the HDBaseT port in **HDBaseT Signal Level**.
 - ☛ **Info - Projector Info - HDBaseT Signal Level** [p.158](#)



Basic Usage

This chapter explains how to project and adjust images.

Before turning on the projector, connect your computer or video equipment to the projector.

☛ "Connecting Equipment" p.51

Attention

Install the current breaker for 13 A to 20 A to the wiring in the building that supplies electricity to the projector. Do not connect other devices to the wiring where the current breaker is installed, and use the wiring only for the projector.

- 1 Connect the projector to the power outlet using the power cord, and then attach the cable holder.

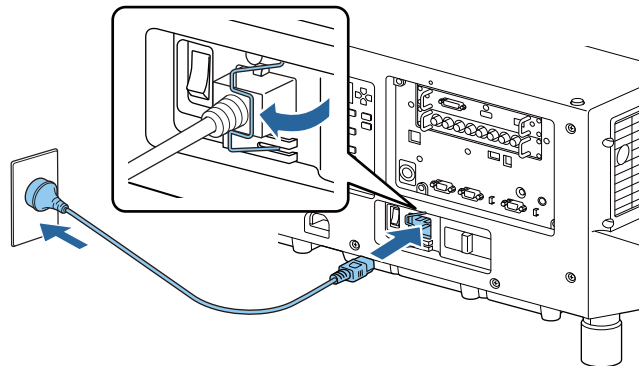

Warning

- There are two types of power cord supplied with the projector, 100 V and 200 V, depending on your country or region. The power cord you need to use may differ depending on your operating environment. Contact a specialist to provide information on handling the power cord.



You can use the 100 V power cord to operate the projector temporarily to determine the installation location. When projecting using the 100 V power cord, the brightness of the projected image is approximately 55% compared to when using a 200 V power cord. Use the 200 V power cord when adjusting the projected image or the lens.

You cannot use the following functions with the 100 V power cord.

- Light Source Mode
- Estimated Remains
- Light Source Calibration

- 2 Turn on the main power switch to supply power to the projector.

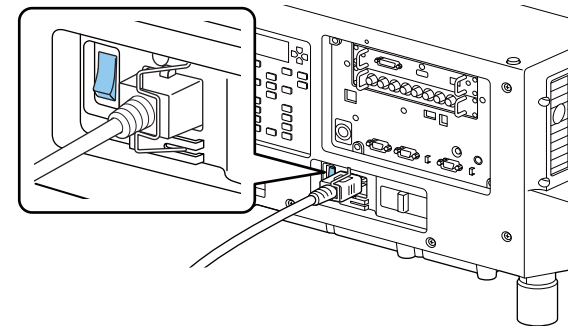

The projector's power indicator turns blue (it is in standby mode). This indicates that the projector is receiving power, but is not yet turned on.

- 3 Press the [ⓘ] button on the control panel or remote control to turn on the projector.

The confirmation buzzer beeps and the status indicator flashes blue as the projector warms up. Once the projector is warmed up, the status indicator stops flashing and turns blue.

If the image is not projected, try the following.

- Turn on the connected computer or video equipment.
- When using a laptop computer, change the screen output of the computer.
- Insert media such as a DVD and play it back.
- Press the [Search] button on the remote control to detect the input source.
- Press the button for the input source that you want to project by using the remote control.

Warning

- Do not look into the projector's lens during projection. Doing so may damage your eyes. Be especially careful if children are present.
- During projection, do not block the light from the projector with a book and so on. If the light from the projector is blocked for a long time, the area on which the light shines becomes hot which could cause it to melt, burn, or start a fire. Also, the lens may get hot due to the reflected light which could cause the projector to malfunction. To stop projection, use the Shutter function, or turn off the projector.



- If **Direct Power On** is set to **On** in the **Extended** menu, the projector automatically turns on when power is supplied to it. When the power cord is plugged in, note that the projector turns on automatically in cases such as recovery from a power outage.
 - ☛ **Extended - Operation - Direct Power On** [p.143](#)
- You can set the shutter status when the projector is turned on in **Shutter Settings** from the **Extended** menu.
 - ☛ **Extended - Operation - Shutter Settings - Startup** [p.143](#)



- To ensure a long projector service life, turn off the projector when you are not using it. The light source's operating life varies depending on the Configuration menu settings, environmental conditions, and usage conditions. The brightness of the projected image drops as projection time elapses.
- The projector can be powered off directly by the breaker because it supports the direct shutdown function.
- When the projector is used continuously for more than 24 hours, or when direct shutdown is used regularly, set **Light Source Calibration** using the scheduling function to adjust the light source periodically. You can also make settings from the Configuration menu.
 - ☛ "Scheduling Function" [p.107](#)
 - ☛ **Reset - Light Source Calibration** [p.159](#)

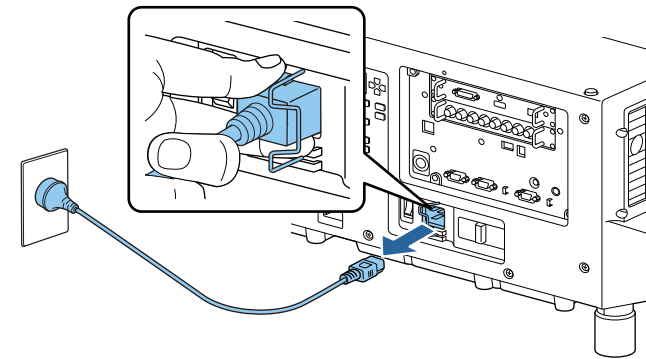

The power cord is shipped according to the power specifications of the country in which it is sold. If there is a lock on the power plug, unplug the power cord while pressing the lock.

- 1** Press the [⏻] button on the control panel or the remote control. The shutdown confirmation screen is displayed.

Power Off?

Yes: Press  button

No : Press any other button

- 2** Press the [⏻] button again. (To cancel, press any other button.) After the buzzer beeps twice, the projected image disappears, and the status indicator turns off.
- 3** Turn off the main power switch. The power indicator turns off.
- 4** Remove the cable holder and unplug the power cord.

You can change the image you want to project when connecting multiple devices to the projector.

- 1 Check that the connected devices are turned on.
- 2 When projecting video from a video device, insert media such as a DVD, and then play it.
- 3 Perform one of the following operations.

- Press the [Search] button on the remote control until images from the target device are displayed.

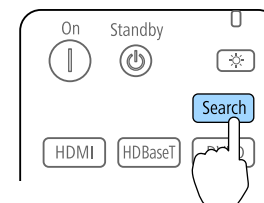

 The following screen is displayed while no image signals are input.

[Source Search]	
	Signal Status
HDBaseT	Off
HDMI (Slot1)	Off
DVI-D (Slot1)	Off
SDI1 (Slot2)	Off
SDI2 (Slot2)	Off
SDI3 (Slot2)	Off
SDI4 (Slot2)	Off
Computer	Off
LAN	Off

·Input an image signal.
·Press to select the source.

[]:Select []:Enter [Esc]:Exit

- On the remote control, press the button for the source that you want to project. If there are multiple sources that match the button you pressed, press the button again to switch the source.

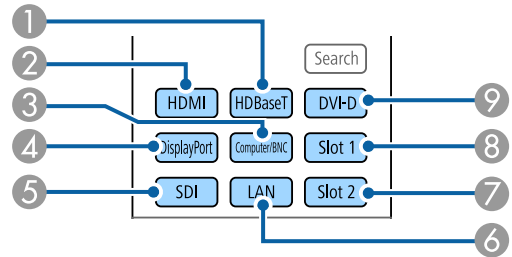

- ① HDBaseT port
- ② HDMI port
- ③ Computer In port
- ④ DisplayPort1 In port/DisplayPort2 In port
(When installing an optional DisplayPort interface board)
- ⑤ SDI1 In port/SDI2 In port/SDI3 In port/SDI4 In port
- ⑥ LAN
- ⑦ Input ports on Slot2
- ⑧ Input ports on Slot1
- ⑨ DVI-D port

- On the control panel, press the button for the source that you want to project. If there are multiple sources that match the button you pressed, press the button again to switch the source.

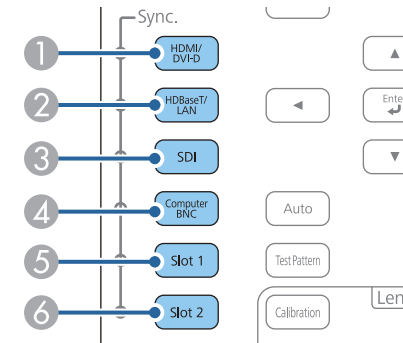

- ① HDMI port/DVI-D port
- ② HDBaseT port/LAN
- ③ SDI1 In port/SDI2 In port/SDI3 In port/SDI4 In port
- ④ Computer In port
- ⑤ Input ports on Slot1
- ⑥ Input ports on Slot2



- The Sync. indicator turns on for the source that is receiving an image signal. The light also turns on for the button of the source being projected.
- You can enable/disable each input port.
 - ☛ **Extended - Operation - Video Terminal Settings p.143**
- If there are multiple sources that match the button you pressed, the source changes in the same order as on the **Source Search** screen. For example, if you connect HDMI/DVI-D interface boards to Slot1 and Slot2 and then press the [HDMI] button, the order changes in the following order.
HDMI (Slot1) - HDMI (Slot2)
- When these are replaced with optional interface boards, the changing order is Slot1 to Slot2. For example, if you connect HDMI/DVI-D interface boards to Slot1 and Slot2 and then press the [HDMI/DVI-D] button, the order changes in the following order.
HDMI (Slot1) - DVI-D (Slot1) - HDMI (Slot2) - DVI-D (Slot2)
- When SDI interface boards are installed in Slot1 and Slot2, Slot1 and Slot2 are not recognized at the same time. Press the Slot1/Slot2 buttons to switch to the slot you want to recognize.

Correcting Distortion in the Projected Image

You can correct keystone distortion in projected images using one of the following methods.

- H/V-Keystone

This allows you to correct distortion in the horizontal and vertical directions independently.

☛ "H/V-Keystone" [p.66](#)

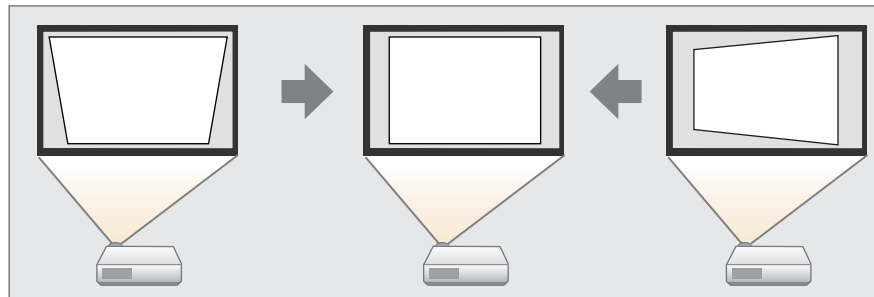

- Quick Corner

Correct the four corners independently.

☛ "Quick Corner" [p.67](#)

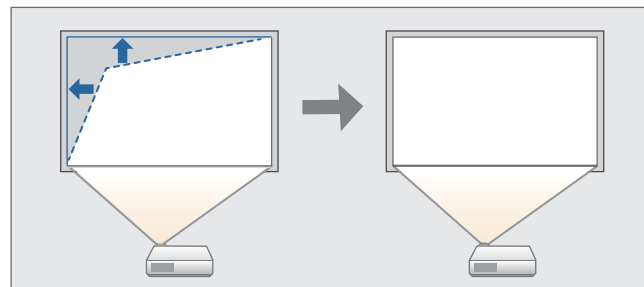

- Curved Surface

Correct distortion that occurs when projecting on a curved surface, and adjust the amount of expansion and contraction.

☛ "Curved Surface" [p.68](#)

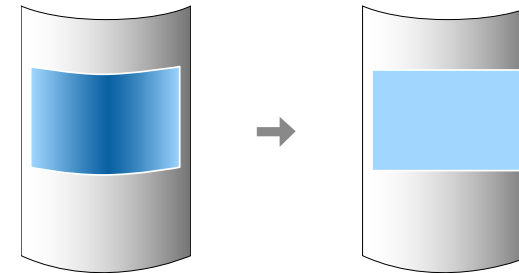

- Corner Wall

This allows you to correct distortion that occurs when projecting on a surface with right angles, such as a square pillar or the corner of a room, and adjust the amount of expansion and contraction.

☛ "Corner Wall" [p.71](#)

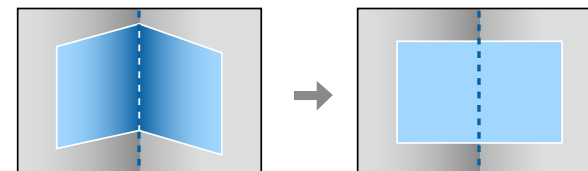

- Point Correction

Corrects slight distortion which occurs partially, or adjusts the image position in an overlapping area when projecting from multiple projectors.

☛ "Point Correction" [p.75](#)

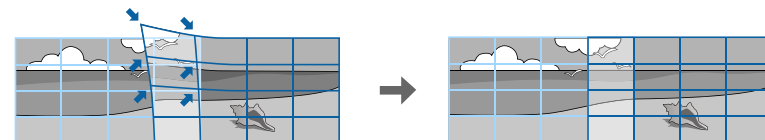



- When you want to re-adjust the projection position and so on, if you want to release the correction status temporarily, set the **Geometry Correction** to **Off**. Even when it is set to **Off**, the correction values are saved.
 - ☛ **Settings - Geometry Correction** p.141
- You can save the geometry correction settings using **Memory** in **Geometry Correction**, and load them when needed.
 - ☛ "Memory Function" p.105
- You can also make settings from the Configuration menu.
 - ☛ **Settings - Geometry Correction** p.141

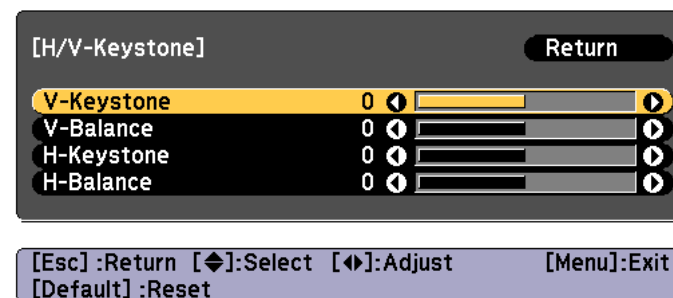

H/V-Keystone

This allows you to correct distortion in the horizontal and vertical directions independently.

Use the following to check the adjustment range for the image.

☛ "H/V-Keystone" p.239

- 1** Press the [Geometry] button while projecting.
- 2** Select **H/V-Keystone**, and then press the [↵] button.
If the message "If this setting is changed, the image may be distorted." is displayed, press the [↵] button.
- 3** Use the [▲][▼] buttons to select the correction method, and then use the [◀][▶] buttons to make the corrections.

Correct the keystone distortion by using **V-Keystone** and **H-Keystone**.

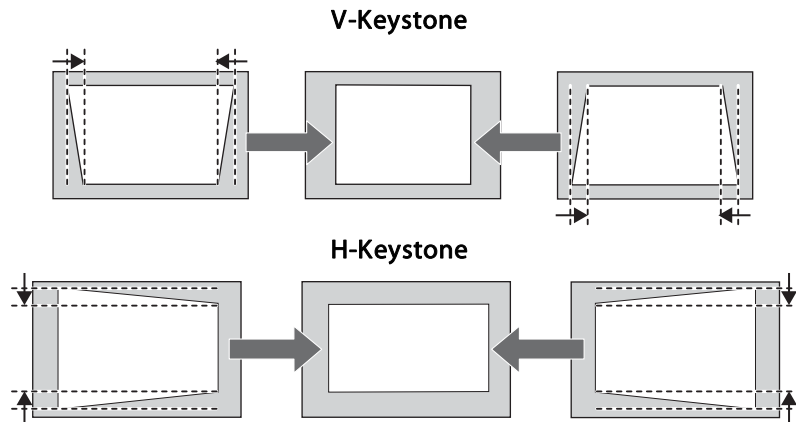

If the image aspect is incorrect, adjust the image balance by using **V-Balance** and **H-Balance**.

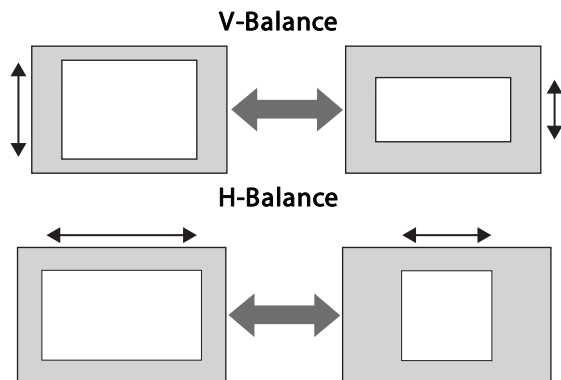

When you correct keystone distortion, the projected image may be reduced.

4 To complete the corrections, press the [Menu] button.



You cannot combine with other correction methods.

Quick Corner

This allows you to correct each of the four corners of the projected image independently.

- 1** Press the [Geometry] button while projecting.
- 2** Select **Quick Corner**, and then press the [↵] button.
If the message "If this setting is changed, the image may be distorted." is displayed, press the [↵] button again.
- 3** Use the [▲], [▼], [◀], and [▶] buttons to select the corner you want to adjust, and then press the [↵] button.

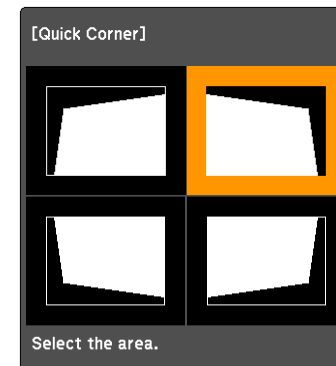

[↔/↕]: Select
 [↵]: Enter
 [Esc] : Return (press for 2 seconds to reset)



If the [Esc] button is pressed for approximately two seconds, the confirm default reset screen is displayed.
Select **Yes** to reset the result of Quick Corner corrections.

- Use the [▲], [▼], [◀], and [▶] buttons to correct the position of the corner.

When you press the [↵] button, the screen shown in step 3 that allows you to select the area to be corrected is displayed.

If the message "Cannot adjust any further." is displayed while adjusting, you cannot adjust the shape any further in the direction indicated by the gray triangle.

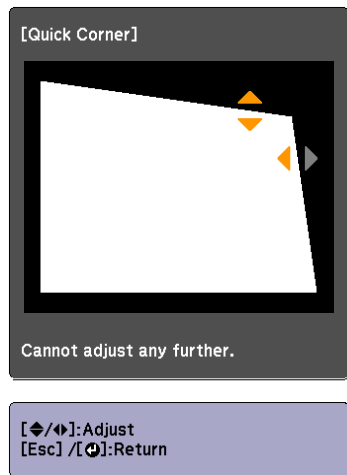

- Repeat steps 3 and 4 as needed to adjust any remaining corners.
- To complete the corrections, press the [Menu] button.

Curved Surface

This allows you to correct distortion that occurs when projecting on a curved surface, and adjust the amount of expansion and contraction.

Face the projector directly opposing the screen with the lens position moved to the home position.

☛ "Adjusting the Position of the Projected Image (Lens Shift Adjustment)" p.38



- Project onto an arc surface with the same radius.
- If a large amount of adjustment is performed, the focus may not be uniform even after making adjustments.

Use the following to check the adjustment range for the image.

☛ "Curved Surface" p.239

- Press the [Geometry] button while projecting.
- Select **Curved Surface**, and then press the [↵] button.

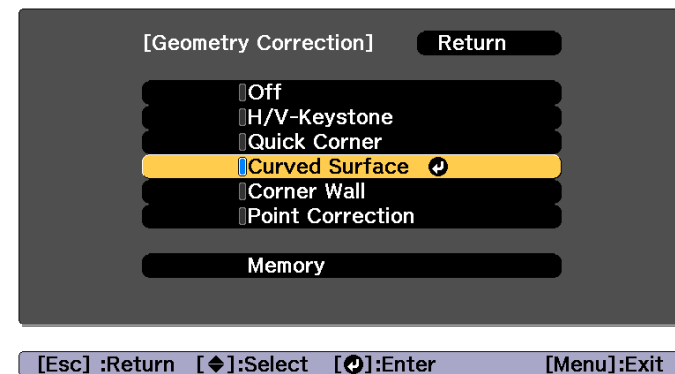

If the message "If this setting is changed, the image may be distorted." is displayed, press the [↵] button.

3 Select **Curved Surface**, and then press the [**↵**] button.

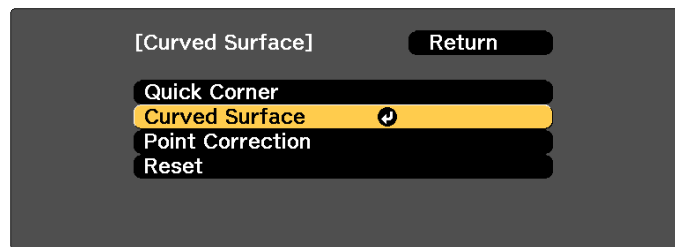

[Esc] :Return [↩]:Select [→]:Enter [Menu]:Exit

4 Select **Correct Shape**, and then press the [**↵**] button.

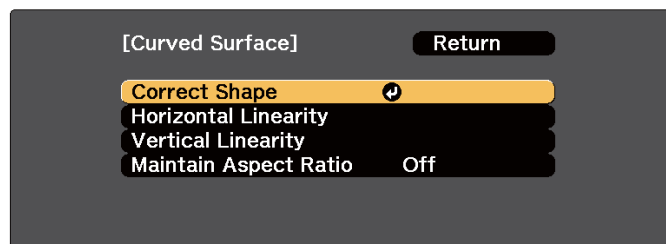

[Esc] :Return [↩]:Select [→]:Enter [Menu]:Exit

5 Use the [**▲**], [**▼**], [**◀**], and [**▶**] buttons to select the area you want to adjust, and then press the [**↵**] button.

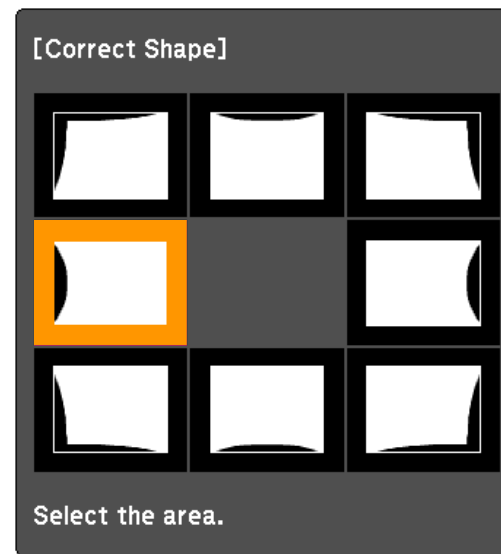

When selecting a corner, you can adjust the two sides next to the corner.

 If the [Esc] button is pressed for approximately two seconds, the confirm default reset screen is displayed. Select **Yes** to reset the result of Curved Surface.

- 6** Use the [▲], [▼], [◀], and [▶] buttons to adjust the shape.

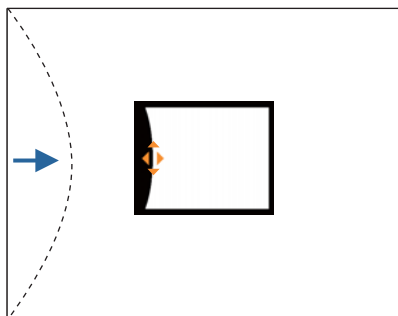

If the triangle in the direction you are adjusting the shape turns gray, as shown in the screenshot below, you cannot adjust the shape any further in that direction.

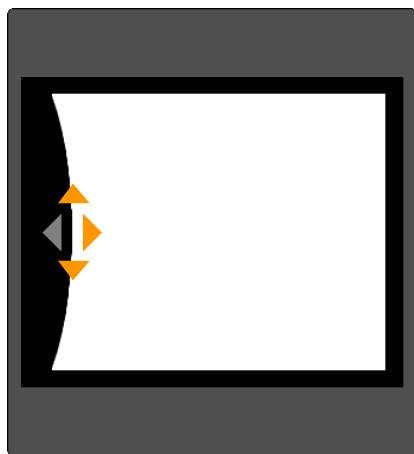

- 7** Press the [Esc] button to return to the previous screen.

- 8** Repeat steps from 5 to 7 as needed to adjust any remaining parts.

If the image expands or contracts, go to the next step and adjust the linearity.

- 9** Press the [Esc] button to return to the screen in step 4. Select **Horizontal Linearity** or **Vertical Linearity**, and then press the [↵] button.

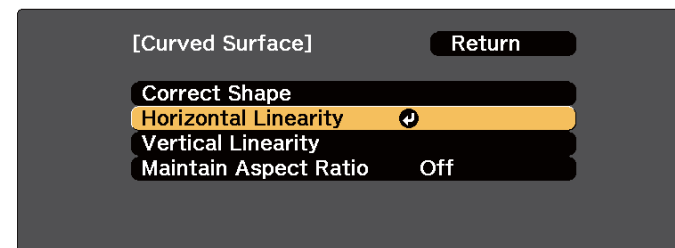

[Esc]:Return [◆]:Select [↵]:Enter [Menu]:Exit

Select **Horizontal Linearity** to adjust the horizontal expansion or contraction, and select **Vertical Linearity** to adjust the vertical expansion or contraction.



To compensate for expansion or contraction while maintaining the aspect ratio, set **Maintain Aspect Ratio** to **On**. You may not be able to perform corrections if you set this to **On** after correction. In this situation, return the corrections to their initial values, or reduce the amount of correction, and then try again.

- 10** Select the standard line for the adjustments, and then press the [↵] button.

Press the [◀][▶] buttons when selecting **Horizontal Linearity**, and the [▲][▼] buttons when selecting **Vertical Linearity**, and then press [↵].

The selected standard line is displayed in flashing orange and white.



Changing the standard line resets the previous settings.

11 Adjust the linearity.

Correct it so that the distance between lines is equal.

When pressing the [◀] button

When **Horizontal Linearity** is selected When **Vertical Linearity** is selected

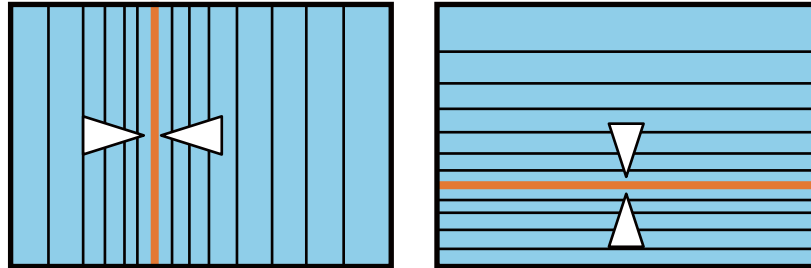

When pressing the [▶] button

When **Horizontal Linearity** is selected When **Vertical Linearity** is selected

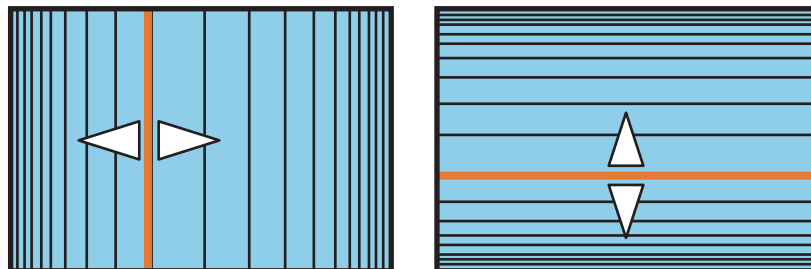

12 To complete the corrections, press the [Menu] button.



You can fine tune the corrected results. Use **Quick Corner** to adjust the tilt of the image, and then use **Point Correction** for fine tuning. Select **Quick Corner** or **Point Correction** on the screen from step 3.

☛ "Quick Corner" p.67

☛ "Point Correction" p.75

Corner Wall

This allows you to correct distortion that occurs when projecting on a surface with right angles, such as a square pillar or the corner of a room, and adjust the amount of expansion and contraction.

Face the projector directly opposing the screen with the lens position moved to the home position.

☛ "Adjusting the Position of the Projected Image (Lens Shift Adjustment)" p.38



- Project onto a surface with a right angle.
- If a large amount of adjustment is performed, the focus may not be uniform even after making adjustments.

Use the following to check the adjustment range for the image.

☛ "Corner Wall" p.243

- 1 Press the [Geometry] button while projecting.
- 2 Select **Corner Wall**, and then press the [↵] button.

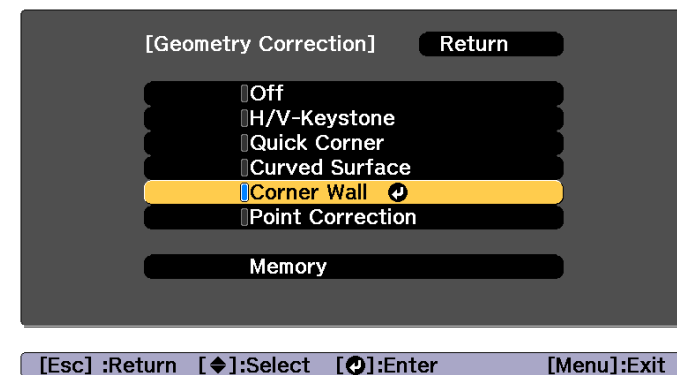

If the message "If this setting is changed, the image may be distorted." is displayed, press the [↵] button again.

- 3** Select **Corner Wall**, and then press the [**↵**] button.

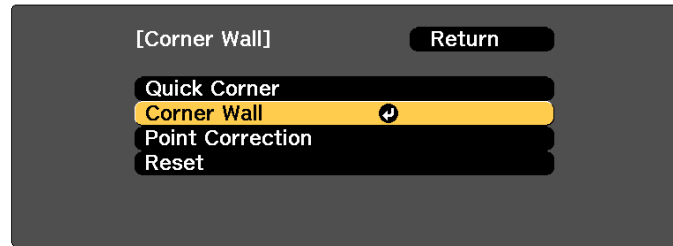

[Esc] :Return [↵]:Select [↵]:Enter [Menu]:Exit

- 4** Select **Corner Type**, and then press the [**↵**] button.

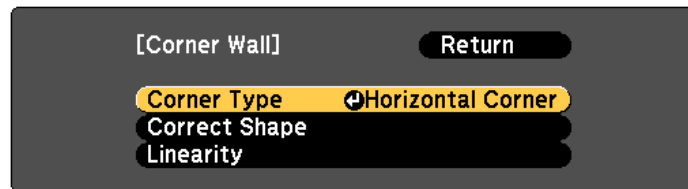

[Esc] :Return [↵]:Select [↵]:Enter [Menu]:Exit

- 5** According to the projection area, select **Horizontal Corner** or **Vertical Corner**, and then press the [**↵**] button.

When the surfaces line up horizontally:
Select **Horizontal Corner**.

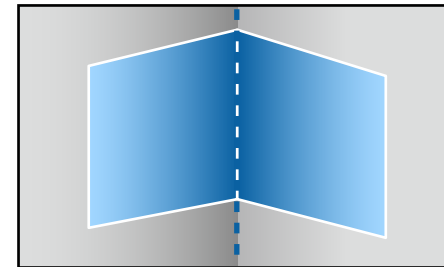

When the surfaces line up vertically:
Select **Vertical Corner**.

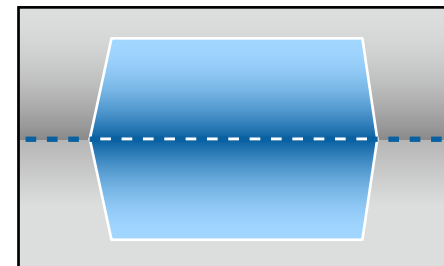



From here on, steps are explained using **Horizontal Corner** as an example.

- 6** Press the [Esc] button to display the screen from step 4. Select **Correct Shape**, and then press the [**↵**] button.

7 Adjust the position of the projector and the lens shift so that the line in the center of the screen matches the corner (the point where the two surfaces meet).

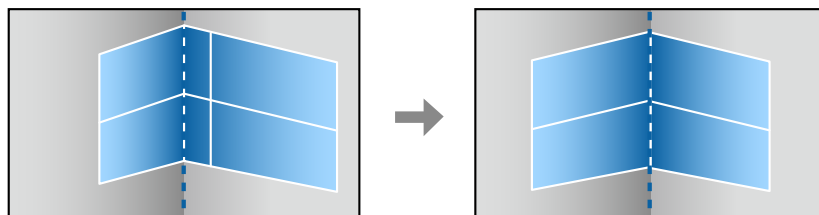
☛ "Adjusting the Position of the Projected Image (Lens Shift Adjustment)" p.38



 Each time you press the [↵] button, you can show or hide the image and the grid.

8 Use the [▲], [▼], [◀], and [▶] buttons to select the area you want to adjust, and then press the [↵] button.

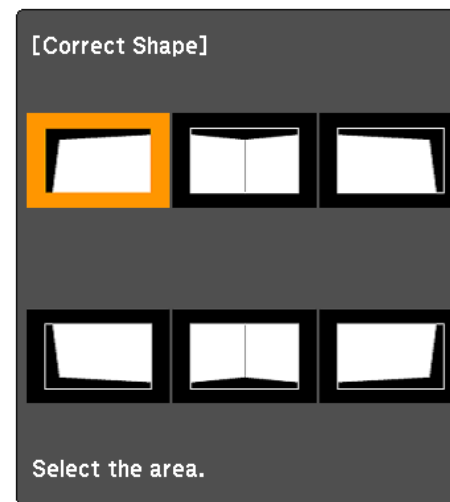

Adjustment tips

When **Horizontal Corner** is selected:

Adjust the upper area based on the lowest point (indicated by the Ⓐ arrow).

Adjust the lower area based on the highest point (indicated by the Ⓑ arrow).

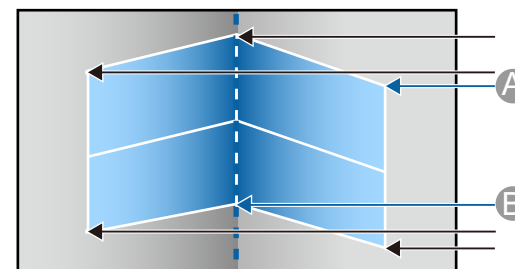

When **Vertical Corner** is selected:

Adjust the left and right based on the point nearest to the vertical line in the center of the screen.



If the [Esc] button is pressed for approximately two seconds, the confirm default reset screen is displayed.

Select **Yes** to reset the result of **Corner Wall**.

9 Press the [▲][▼][◀][▶] buttons to adjust the shape.

If the message "Cannot adjust any further." is displayed while adjusting, you cannot adjust the shape any further in the direction indicated by the gray triangle.

10 Repeat steps 8 and 9 as needed to adjust any remaining parts. If the image expands or contracts, go to the next step and adjust the linearity.

11 Press the [Esc] button to display the screen from step 3. Select **Linearity**, and then press the [↵] button.

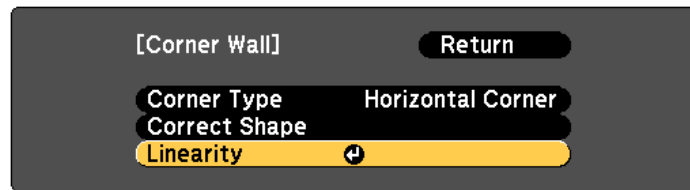

[Esc]:Return [◀]:Select [↵]:Enter [Menu]:Exit

12 Press the [◀][▶] buttons to adjust the linearity.

Correct it so that the distance between lines is equal.

When pressing the [◀] button

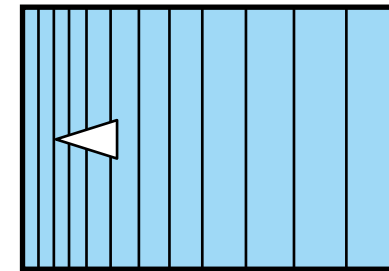

When **Vertical Corner** is selected

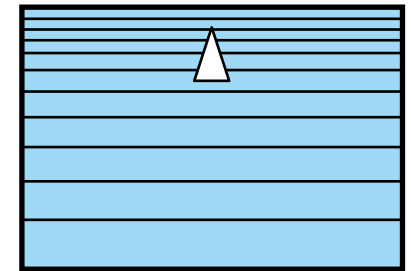

When pressing the [▶] button

When **Horizontal Corner** is selected

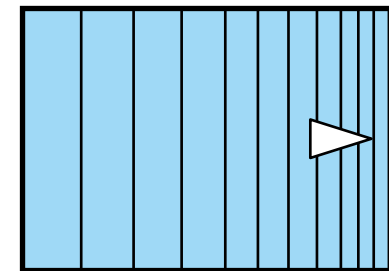

When **Vertical Corner** is selected

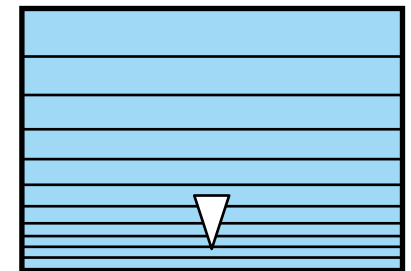

13 To complete the corrections, press the [Menu] button.



You can fine tune the corrected results. Use **Quick Corner** to adjust the tilt of the image, and then use **Point Correction** for fine tuning. Select **Quick Corner** or **Point Correction** on the screen from step 3.

☛ "Quick Corner" p.67

☛ "Point Correction" p.75

Point Correction

Divides the projected image by the grid and corrects the distortion by moving the point of intersection from side to side and up and down.



You can make corrections by 0.5 pixels in each direction up to a maximum of 32 pixels.

- 1 Press the [Geometry] button while projecting.
- 2 Select **Point Correction**, and then press the [↵] button.

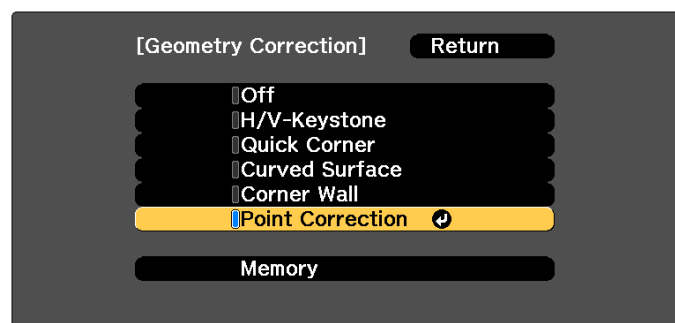

If the message "If this setting is changed, the image may be distorted." is displayed, press the [↵] button again.

- 3 Select **Point Correction**, and then press the [↵] button.

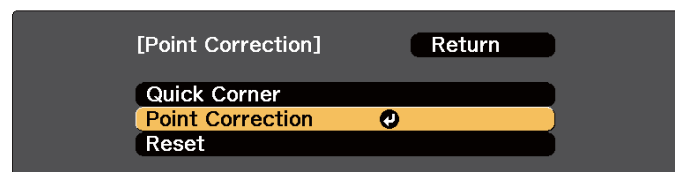

- 4 Select **Point Correction**, and then press the [↵] button.

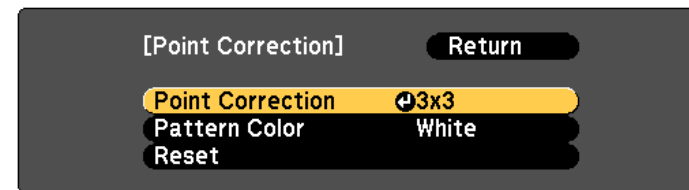

[Esc]:Return [↵]:Select [↵]:Enter [Menu]:Exit

Point Correction	Select the point number (3x3, 5x5, 9x9, 17x17), and then make the Point Correction setting.
Pattern Color	Select the color of the grid when performing corrections.
Reset	Resets all corrections for Point Correction to their default values.

- 5 Select the point number (**3x3**, **5x5**, **9x9**, or **17x17**), and then press the [↵] button.



If you reduce the number of points during correction, corrections at the position without a point are reset.

- 6** Use the [▲], [▼], [◀], and [▶] buttons to move to the point you want to correct, and then press the [↵] button.

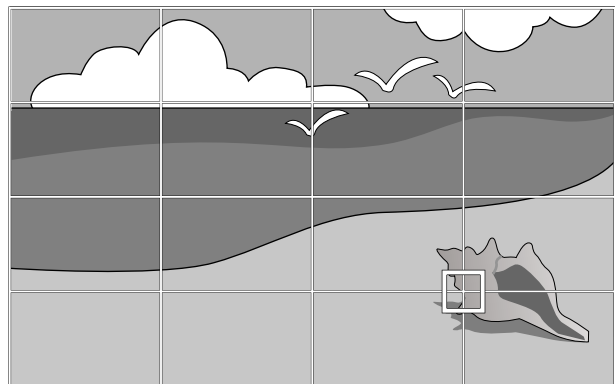

- 7** Use the [▲], [▼], [◀], and [▶] buttons to correct distortion.

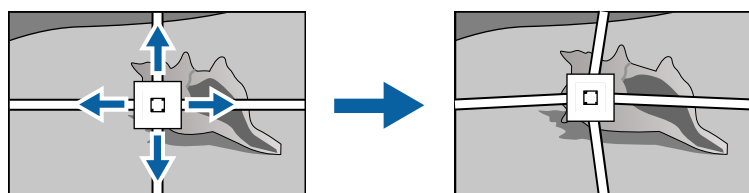

To continue to correct another point, press the [Esc] button to return to the previous screen, then repeat the steps 6 and 7.



Each time you press the [↵] button, you can show or hide the image and the grid.

- 8** To complete the corrections, press the [Menu] button.



You can fine tune the corrected results. Select **Quick Corner** on the screen from step 3 to adjust the tilt of the image.

☞ "Quick Corner" p.67



Selecting the Projection Quality (Selecting Color Mode)

You can easily obtain the optimum image quality simply by selecting the setting that best corresponds to your surroundings when projecting. The brightness of the image varies depending on the mode selected.

Mode	Application
Dynamic	This is the brightest mode. Ideal for use in a bright room.
Presentation	The images are vivid and brought to life. Ideal for making presentations or watching a TV program in a bright room.
Natural	Reproduces colors faithfully. Ideal for projecting still pictures such as photos.
Cinema	Gives images a natural tone. Ideal for watching films in a dark room.
BT.709	Produces images that conform to the ITU-R BT.709. This is ideal for watching digital TV or Blu-ray discs.
DICOM SIM	This produces images with clear shadows. Ideal for projecting X-ray photographs and other medical images. The projector is not a medical device and cannot be used for medical diagnosis.
Multi-Projection	Minimize the color tone difference between each projected image. Ideal for projecting from multiple projectors.

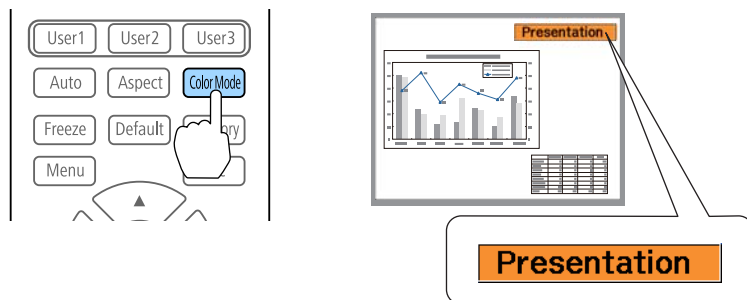
Each time you press the [Color Mode] button on the remote control, the Color Mode name is displayed on the screen and the Color Mode changes.



 You can set Color Mode from the Configuration menu.
 Image - Color Mode [p.137](#)

Setting the Brightness

Set the brightness for the light source.

- 1** Press the [Menu] button while projecting.
- 2** Select **Brightness Settings** from **Settings**.
- 3** Select **Light Source Mode**, and then press the [↵] button.
- 4** Select the item you want to set, and then press the [↵] button.

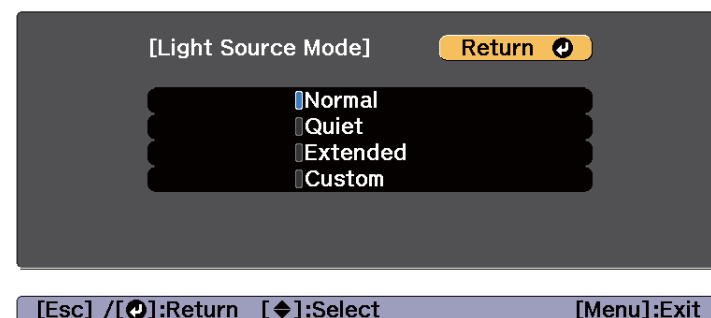

Normal: Select this if you do not want to decrease the brightness. This makes the light source operation time approximately 20,000 hours.

Quiet: Select this if you are concerned about the noise made by the fan. This sets the brightness at 70%. This makes the light source operation time approximately 20,000 hours.

Extended: Select this to extend the life expectancy of the light source. This sets the brightness at 70%. This makes the light source operation time approximately 43,000 hours.

Custom: Select this to set the **Brightness Level** manually. When **Custom** is selected, **Constant Brightness** is available.







- 5** When **Light Source Mode** is set to **Custom**, select **Brightness Level**, and then use the [◀][▶] buttons to set the brightness.

 When there is a limit to the maximum adjustment value for the brightness level, the maximum value is displayed below **Brightness Level**.

- 6** To maintain a fixed brightness, select **Constant Brightness**, and set it to **On**.



- When **Constant Brightness** is set to **On**, you cannot change the settings for **Light Source Mode** and **Brightness Level**. When you want to change these settings, set **Constant Brightness** to **Off**.
- When **Constant Brightness** is set to **Off**, the value for **Brightness Level** changes depending on the current status of the light source.
- There may be a margin of error in the **Brightness Level**.
- When the projector is used continuously for more than 24 hours, or when direct shutdown is used regularly, set **Light Source Calibration** using the scheduling function. If this is not set, the Constant Brightness function does not work. You can also make settings from the Configuration menu.
 - ☛ "Scheduling Function" p.107
 - ☛ Reset - Light Source Calibration p.159

Display Level	Actual Time Remaining
	10,000 hours or more
	8,000 to 9,999 hours
	6,000 to 7,999 hours
	4,000 to 5,999 hours
	2,000 to 3,999 hours
	0 to 1,999 hours



Estimated Remains displays the amount of time remaining in hours without the minutes remaining.

Guide to Estimated Remains

When **Constant Brightness** is set to **On**, the Estimated Remains is displayed. Estimated Remains indicates the amount of time for which constant brightness can be maintained.

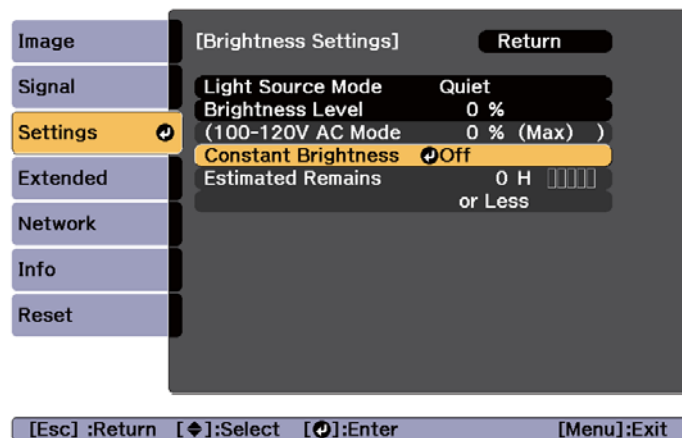

Relationship between Brightness Level and light source operation time

The following shows the relationship between Brightness Level and the light source operation time.

When Constant Brightness is set to Off

- ①: Brightness Level
- ②: Approximate operation time until light source brightness is reduced by half

①	②
100%	20,000 hours
90%	36,000 hours
80%	41,000 hours
70%	43,000 hours
60%	46,000 hours
50%	57,000 hours
40%	75,000 hours

①	②
30%	103,000 hours

When Constant Brightness is set to On

- ①: Brightness Level
- ②: Approximate time for which constant brightness of the light source can be maintained

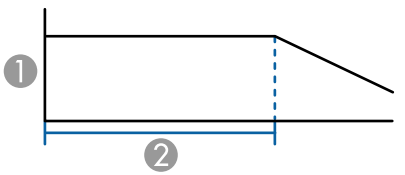
①	②	Illustration
85%	7,000 hours	
80%	15,000 hours	
70%	25,000 hours	
60%	35,000 hours	
50%	47,000 hours	
40%	66,000 hours	
30%	95,000 hours	



- This is an approximate guide only and may change depending on the projector's usage and surroundings.
- The times above are the standard hours when using the projector continuously without changing the **Brightness Level** or **Constant Brightness** settings and are not guaranteed.
- This is an approximate guide only and may change depending on the projector's usage and surroundings. You may need to replace internal parts sooner than the estimated light source operation time.
- When **Constant Brightness** is set to **On**, and the approximate constant time has been exceeded, you may not be able to set a high value for **Brightness Level**.

Setting the Amount of Light of the Projected Image

By automatically setting the luminance according to the brightness of the displayed image, it lets you enjoy deep and rich images. You can also set the light source to turn off automatically.

- 1 Press the [Menu] button while projecting.
- 2 Select **Light Source Control** from **Image**, and then press the [↵] button.
- 3 Select **Light Source Control**, and then press the [↵] button.

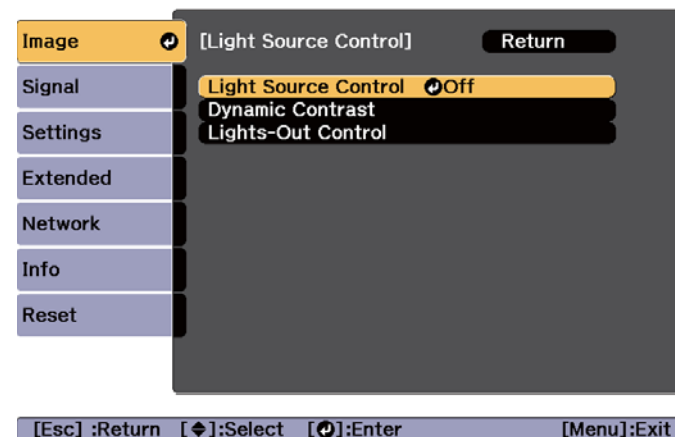

- 4 Select the light source operation according to the image signal, and then press the [↵] button.

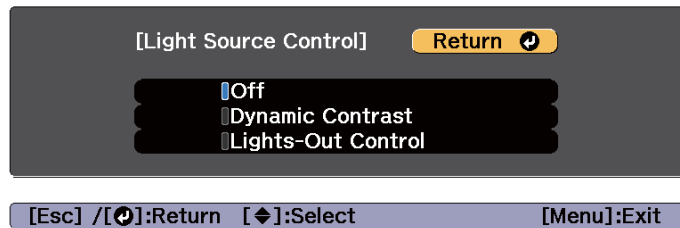

- **Off:** Select if you do not want to control the light source.
- **Dynamic Contrast:** Automatically adjust the amount of light when projecting according to the brightness of the image.
- **Lights-Out Control:** Automatically turns off the light after the set time has elapsed at the specified video level.

5 Press the [Esc] button to return to the previous screen.

6 If you selected **Dynamic Contrast** in step 4, make the following settings in **Dynamic Contrast**.

- **Response Speed:** Select **High Speed** to adjust the amount of light as soon as the scene changes.
- **Black Level:** Set the black level when the brightness level of the image signal is zero. When you select **0%**, the light source turns off.

7 If you selected **Lights-Out Control** in step 4, make the following settings in **Lights-Out Control**.

- **Lights-Out Signal Level:** Set the brightness level for the video signal being controlled. After turning off automatically when exceeding the specified image level, it turns on immediately.
- **Lights-Out Timer:** Set the amount of time before automatically turning off the light source.

8 Press the [Menu] button to finish making settings.

Changing the Aspect Ratio of the Projected Image

You can change the aspect ratio of the projected image to suit the type, the ratio of height and width, and the resolution of the input signals.

Available aspect modes vary depending on the Screen Type currently set.

- Set the **Screen Type** before changing the aspect ratio.
 - ☛ "Screen Settings" p.36
- This cannot be changed when **Scale Mode** is set to **Zoom Display**.
 - ☛ **Signal - Scale - Scale Mode** p.138
- This cannot be changed when **Link Type** is set to **Dual (3840x2160)** or **Dual (1920x2160 Split Screen)** in **DisplayPort Settings**.

Changing methods

Each time you press the [Aspect] button on the remote control, the aspect mode name is displayed on the screen and the aspect ratio changes.

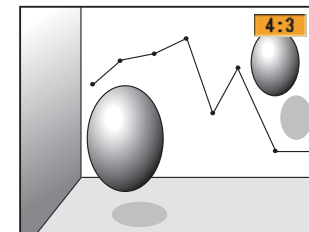
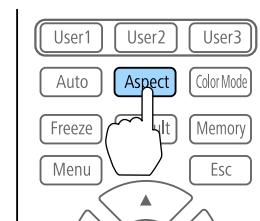

Aspect Mode	Explanation
Auto	Projects in an appropriate aspect ratio based on information from the signal being input.
Normal	Projects while retaining the aspect ratio of the input image.
4:3	Projects at an aspect ratio of 4:3.
16:9	Projects at an aspect ratio of 16:9.

Aspect Mode	Explanation
Full	Projects at the full size of the projected screen.
H-Zoom	Projects by enlarging the input image to the full width of the projected screen while retaining the aspect ratio. Areas that exceed the edges of the projected screen are not projected.
V-Zoom	Projects by enlarging the input image to the full height of the projected screen while retaining the aspect ratio. Areas that exceed the edges of the projected screen are not projected.
Native	Projects to the center of the projected screen at the resolution of the input image. Areas that exceed the edges of the projected screen are not projected.



- The available aspect ratios differ depending on the input signal from the connected device.
- You can also set the aspect ratio from the Configuration menu.
 🖱️ **Signal - Aspect** p.138
- If parts of the computer image are missing, set the **Resolution** setting to **Wide** or **Normal** from the Configuration menu, according to the resolution of the computer.
 🖱️ **Signal - Resolution** p.138

Adjusting the Image

Hue, Saturation, and Brightness adjustment

You can adjust the **Hue** (tint), **Saturation** (vividness), and **Brightness** of the six axes R (red), G (green), B (blue), C (cyan), M (magenta), and Y (yellow) according to your preferences.

- 1 Press the [Menu] button while projecting.

- 2 Select **Advanced** from **Image**, and then press the [↵] button.
- 3 Select **RGBCMY**, and then press the [↵] button.
- 4 Use the [▲][▼] buttons to select the color you want to adjust, and then press the [↵] button.

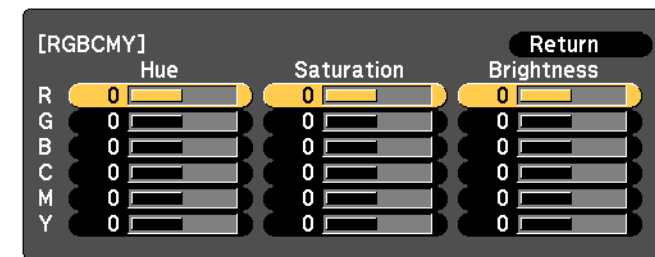

[Esc]:Return [◆]:Select [⏎]:Enter [Menu]:Exit

- 5 Use the [▲][▼] buttons to select the item, and then use the [◀][▶] buttons to make the adjustments.

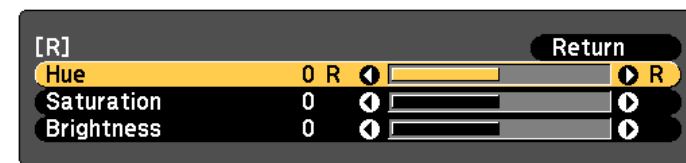

[Esc]:Return [◆]:Select [◀▶]:Adjust [Menu]:Exit
[Default]:Reset [⏎]:Display

Each time you press the [↵] button, the adjustment screen changes.

- 6 To complete the corrections, press the [Menu] button.

Gamma adjustment

You can adjust differences in the halftone brightness that occurs depending on the connected device.



Adjust by projecting a still picture. Gamma cannot be adjusted correctly by using movies.

- 1 Press the [Menu] button while projecting.
- 2 Select **Advanced** from **Image**, and then press the [↵] button.
- 3 Select **Gamma**, and then press the [↵] button.
- 4 Use the [◀][▶] buttons to adjust the value.

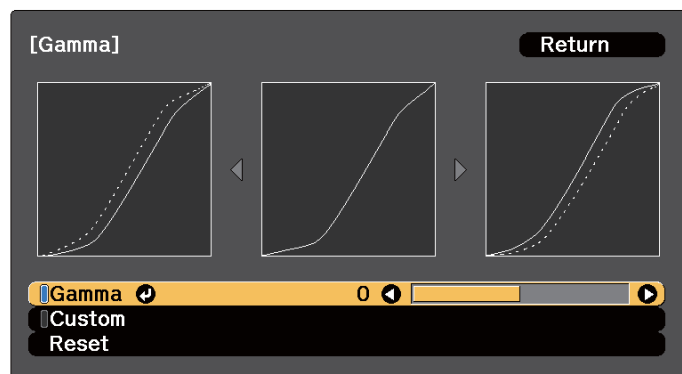

[Esc]:Return [◀▶]:Select [↵]:Set [Menu]:Exit

When a larger value is selected, the dark areas of images become brighter, but the color saturation for lighter areas may become weaker.

When a smaller value is selected, you can reduce the overall brightness of the image to make the image sharper.

If you select **DICOM SIM** from **Color Mode** on the **Image** menu, select the adjustment value according to the projection size.

- If the projection size is 150 inches or less, select a small value.
- If the projection size is 150 inches or more, select a large value.



Medical images may not be reproduced correctly according to your installation environment and screen specifications.

- 5 To make detailed adjustments, select **Custom**, and then press the [↵] button.
- 6 In the gamma adjustment graph, use the [◀][▶] buttons to select the tone that you want to change. Use the [▲][▼] buttons to adjust the selected tone, and then press the [↵] button.

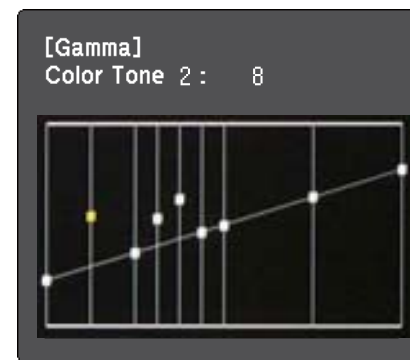

- 7 Press the [Menu] button to finish making adjustments.

Adjusting Image Resolution (Image Enhancement)

You can adjust the resolution of the image using **Image Enhancement** to reproduce a clear image with an emphatic texture and material feel.

- 1 Press the [Menu] button while projecting.
- 2 Select **Image Enhancement** from **Image**, and then press the [↵] button.

The following screen is displayed.

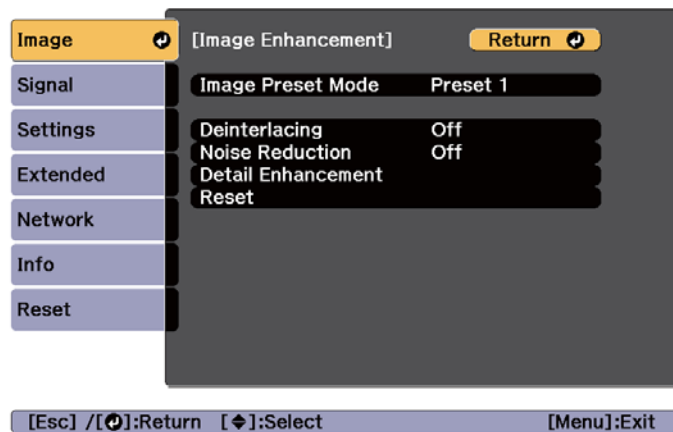

Image Preset Mode

Select the optimal setting according to the projected image from five presets prepared in advance.

The following settings are saved in the presets.

Deinterlacing, Noise Reduction, Detail Enhancement



- To minimize delays, set **Image Preset Mode** to **Off**.
- If you set **Image Preset Mode** to **Off**, you cannot set the other items in **Image Enhancement**.

- 1 Select **Image Preset Mode** from **Image Enhancement**, and then press the [↵] button.
- 2 Select one of the following, and then press the [↵] button.
Preset 1 to Preset 5: The settings saved in advance are applied to the image.
Off: Select this to turn off presets.

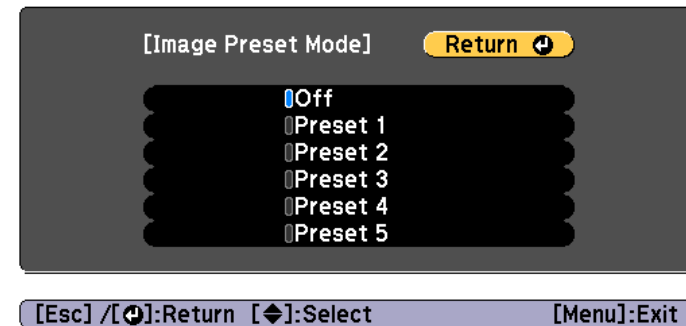

After selecting **Preset 1 to Preset 5**, you can fine tune each setting individually. The setting after adjustment will be overwritten.

- 3 Press the [Esc] button to return to the previous screen.

Noise Reduction

You can smooth out rough images for softer image quality when inputting progressive signals or progressive interlace signals.



You cannot set Noise Reduction when a signal with a horizontal resolution greater than 1920 is being input.

1 Select **Noise Reduction** from **Image Enhancement**, and then press the [**↵**] button.

2 Select **Off** or **1** to **3**, and then press the [**↵**] button.

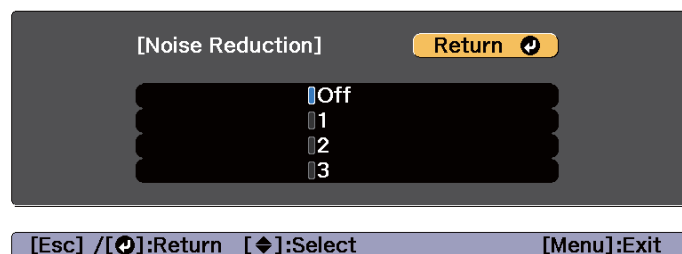

3 Press the [Esc] button to return to the previous screen.

Detail Enhancement

You can enhance the contrast in detailed areas of an image to create a more emphatic texture and material feel.

1 Select **Detail Enhancement** from **Image Enhancement**, and then press the [**↵**] button.

2 Use the [**▲**][**▼**] buttons to select the item, and then use the [**◀**][**▶**] buttons to make the adjustments.

Strength: The larger the value, the more the contrast is enhanced.

Range: The larger the value, the wider the range of detail enhancement becomes.

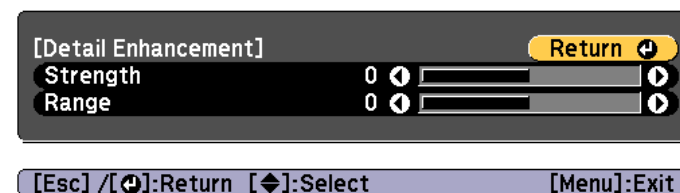

Depending on the image, a highlight may be noticeable at the border between colors. If this bothers you, set a smaller value.

3 Press the [Esc] button to return to the previous screen.



Useful Functions

This section describes the Multi-Projection, Split Screen, Memory, Schedule, and Security functions.

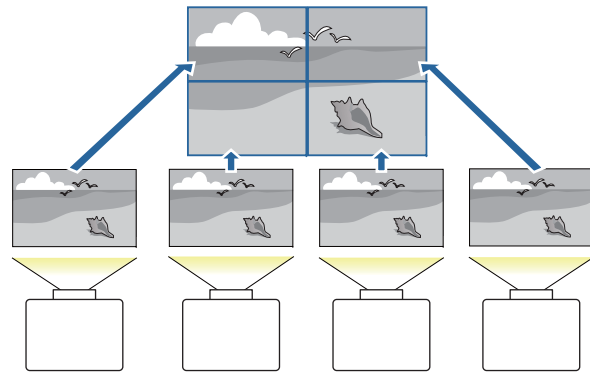

You can setup up to 15 projectors to project one large and wide image. You can adjust the difference of brightness and color tone between each projected image to create a seamless screen.



- We recommend setting the focus, zoom, and lens shift at least 30 minutes after you start the projection, because images are not stable right after turning on the projector.
- If the values for **Geometry Correction** are large, the image position adjustment for overlapping images becomes difficult.
- The Test Pattern can be displayed to adjust the projection status without connecting video equipment.
 - ☛ "Displaying the Test Pattern" [p.37](#)
- If you project a dot by dot image that can be projected without being enlarged or reduced, you can make adjustments precisely.
- When **Run Periodically** is set to **On** in Light Source Calibration, calibration is automatically performed, and colors adjusted using multi-projection may change. Set this to **Off** to maintain the projected image as it is.
 - ☛ **Reset - Light Source Calibration - Run Periodically** [p.159](#)
- If you perform Screen Matching regularly, make sure you execute Screen Matching after performing Light Source Calibration. If there are still differences in the color, set **Run Periodically** to **Off** in **Light Source Calibration**.

Adjustment Procedure

Adjusting automatically online

The arrangement for all projectors (Tiling) and adjustments for the images (Edge Blending) are performed automatically using the projector set as the master projector.

You can automatically correct distortion and overlapping areas in multiple projected images by using the tiling assist function in Epson Projector Professional Tool.

☛ "Tiling Assist" [p.98](#)



When a particularly dark projector is included in the group, the brightness is automatically adjusted according to the dark projector. Use the following method to select the master projector.

- When you want the image to be as bright as possible:
 - Set the **Light Source Mode** for all projectors to **Normal** or **Custom - Brightness Level - 100%**. For the master projector, select a projector whose color and brightness you want to use as the standard.
- When you want to match to a specific brightness:
 - Set the projector with the darkest projected image as the master projector, and then use **Light Source Mode - Custom - Brightness Level** to adjust it so that it has a specific brightness.
 - ☛ **Settings - Brightness Settings - Light Source Mode, Brightness Level** [p.141](#)

Advance preparation

- (1) Connect to the network
 - Connect all projectors to a network hub using LAN cables.

- Set the **DHCP** to **On** for all projectors, or check that IP addresses have been assigned.

☛ **Network - Network Configuration - Wired LAN - IP Settings** p.155

- (2) Set an ID for the master projector and the remote control.

☛ "Set the projector ID" p.47

- (3) Set **Sleep Mode** to **Off**

☛ **Extended - Operation - Sleep Mode** p.143

Adjusting projected images individually

- (1) Unify the size of the images

☛ "Adjusting the Image Size" p.40

- (2) Adjust the orientation and position of the image

☛ "Installation Settings" p.35

☛ "Adjusting the Position of the Projected Image (Lens Shift Adjustment)" p.38

- (3) Fine tune the focus and distortion of the image

☛ "Correcting the Focus" p.41

☛ "Point Correction" p.75

Combining multiple projected images

- (1) Set the arrangement of the images.

☛ "Performing tiling automatically" p.88

- (2) Adjust the edges of the images

☛ "Edge Blending" p.90

☛ "Black Level" p.92

- (3) Unify the brightness and tint of the images

☛ "Screen Matching" p.94

- (4) Splice the images to create one, large image

☛ "Displaying a Scaled Image" p.97

Adjusting manually offline

Adjust the images from all projectors manually.

Advance preparation

Set an ID for all projectors and the remote controls.

☛ "Set the projector ID" p.47

Adjusting projected images individually

- (1) Unify the size of the images

☛ "Adjusting the Image Size" p.40

- (2) Adjust the orientation and position of the image

☛ "Installation Settings" p.35

☛ "Adjusting the Position of the Projected Image (Lens Shift Adjustment)" p.38

- (3) Fine tune the focus and distortion of the image

☛ "Correcting the Focus" p.41

☛ "Point Correction" p.75

Combining multiple projected images

- (1) Set the arrangement of the images.

☛ "Performing tiling manually" p.89

- (2) Adjust the edges of the images

☛ "Edge Blending" p.90

☛ "Black Level" p.92

- (3) Unify the brightness and tint of the images

☛ "Color Matching" p.96

- (4) Splice the images to create one, large image

☛ "Displaying a Scaled Image" p.97

Tiling

When using multiple projectors to create one large image, assign a projection position to each projector.

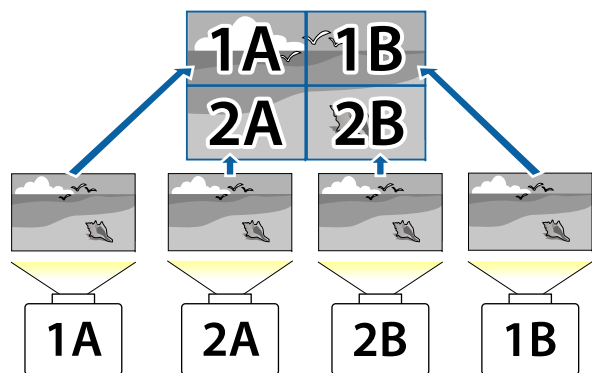

Before performing tiling, adjust the projected image so that it is a rectangle. Also, adjust the size and focus of the images.

- ☛ "Adjusting the Image Size" [p.40](#)
- ☛ "Correcting the Focus" [p.41](#)

Performing tiling automatically

Automatically sets the arrangement for the projectors being used. You can make settings by operating only the master projector.



Location setup is performed using the camera built into the front of the projector. Do not block the camera or the projected images.

- 1** Press the [Menu] button while projecting.
- 2** Select **Multi-Projection** from **Extended**, and then press the [↵] button.

- 3** Select **Projector Grouping**, and then press the [↵] button.

- 4** Select the projectors that will be used for tiling, and then press the [↵] button.

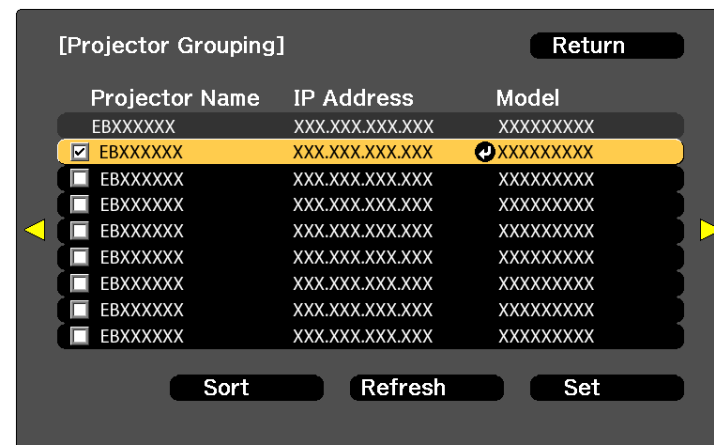

[Esc] :Return [↕]:Select [⏻]:Set [Menu]:Exit

- (1) Select the projectors you want to use to enter a checkmark. Select **Refresh** to update the list. Select **Sort** to sort the projector order.
- (2) Select **Set**, and then press the [↵] button.

- 5** Select **Tiling**, and then press the [↵] button.

- 6** Select **Tiling**. Select **Auto**, and then press the [Esc] button.

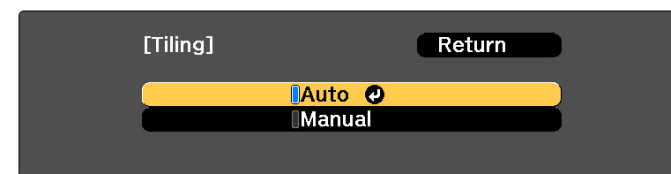

[Esc] :Return [↕]:Select [⏻]:Set [Menu]:Exit

7 Select **Location Setup**, and then press the [↵] button.

The image is positioned automatically.

When the message "Assign IDs to projectors that have been located. Do you want to continue?" is displayed, select **Yes**.

When setup is complete, the following screen is displayed.

[Location Info]		
EBXXXXXX XXXXXXXXXX ID: XX	EBXXXXXX XXXXXXXXXX ID: XX	EBXXXXXX XXXXXXXXXX ID: XX
EBXXXXXX XXXXXXXXXX ID: XX	EBXXXXXX XXXXXXXXXX ID: XX	EBXXXXXX XXXXXXXXXX ID: XX

[Esc]:Return [←▶]:Move [Menu]:Exit



If the image is not located correctly, select **Manual** in step 6, and then follow the steps below to locate the image manually.

- (1) Set **Row** and **Column** in **Layout**.
- (2) Select **Set**, and then press the [↵] button.
- (3) Select the projector in **Location Setup**, and then press the [↵] button.
- (4) Select the position you want to locate, and then press the [↵] button.
- (5) Repeat steps (3) and (4) to reposition the location of all projectors.
- (6) Select **Set**, and then press the [↵] button.

8 Input the image signal to display the image.

☛ "Changing the Projected Image" p.62

When tiling is complete, adjust any positional gaps and the tint of the projected images.

☛ "Adjusting projected images individually" p.87



- After tiling is complete, do not change the IP addresses or projector names of the projectors. Otherwise the image will not be adjusted automatically.
- After tiling is complete, you can set each projector with one remote control. Select the projector ID for the projector you want to set with the remote control. You can check the projector ID in **Tiling - Location Info**.
☛ "Setting the remote control ID" p.47

Performing tiling manually

Manually arrange the images being projected for each projector.

- 1 Press the [Menu] button while projecting.
- 2 Select **Multi-Projection** from **Extended**, and then press the [↵] button.
- 3 Select **Tiling**, and then press the [↵] button.
- 4 Select **Layout**, and then press the [↵] button.
 - (1) Set the number of projectors in **Row** and **Column**.
 - (2) Select **Set**, and then press the [↵] button.
- 5 Repeat steps 1 to 4 for each projector to be used for tiling.

6 Select **Location Setup**, and then press the [**↵**] button.

- (1) Set the positions of the projected images in **Row Order** and **Column Order**.

Row Order: Place screens from top to bottom in the order of 1, 2, 3.

Column Order: Place screens from left to right in the order of A, B, C.

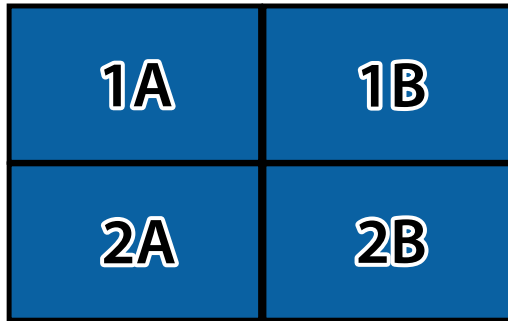

- (2) Select **Set**, and then press the [**↵**] button.

7 Repeat step 6 for each projector.

8 Input the image signal to display the image.

- ☛ "Changing the Projected Image" p.62

When tiling is complete, adjust any positional gaps and the tint of the projected images.

- ☛ "Adjusting projected images individually" p.87

Edge Blending

You can fine tune the overlapping areas to make seamless screen.

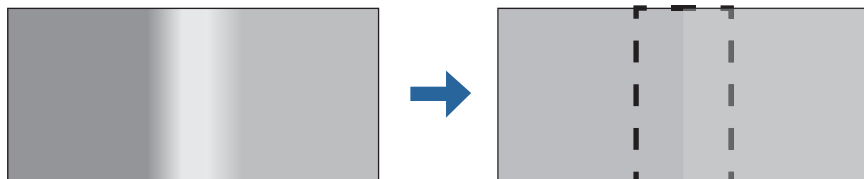

Before performing edge blending to raise the precision of adjustments, press the [Color Mode] button on the remote control, and then set **Color Mode** to **Multi-Projection**.

- 1 Press the [Menu] button while projecting.
- 2 Select **Multi-Projection** from **Extended**.
- 3 Select **Edge Blending**, and then press the [**↵**] button.

The following screen is displayed.

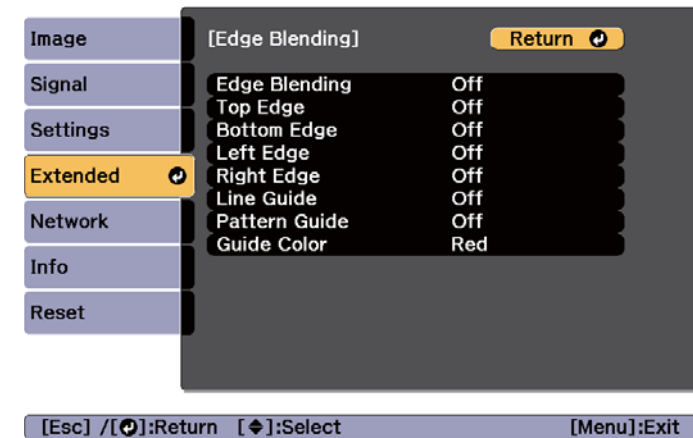

Submenu	Function
Edge Blending	Set to On to activate Edge Blending. Set to Off when not projecting from multiple projectors.

Submenu	Function
Top Edge/Bottom Edge/Left Edge/Right Edge	<p>Blending: Set to On to activate Edge Blending towards your settings, and the blend range will be shaded.</p> <p>Blend Start Position: Displays blending start position as a red line, and adjusts at the level of one pixel.</p> <p>Blend Range: Adjusts the range to be shaded. Adjustment is possible at the level of one pixel. The maximum range is 45% of the resolution.</p> <p>Blend Curve: Adjusts how to apply shading.</p>
Line Guide	Set to On to display a guide on the Edge Blending setting range.
Pattern Guide	Set to On to display a lattice pattern to match the position of the Edge Blending setting range.
Guide Color	Select a combination of guide colors from the six provided.

4 Turn on Edge Blending.

- (1) Select **Edge Blending**, and then press the [↵] button.
- (2) Select **On**, and then press the [↵] button.
- (3) Press the [Esc] button.

5 Set **Line Guide** to **On**.

- (1) Select **Line Guide**, and then press the [↵] button.
- (2) Select **On**, and then press the [↵] button.
- (3) Press the [Esc] button.



If the guide is not clear, you can change the color of the guide in **Guide Color**.

6 Set **Pattern Guide** to **On**.

- (1) Select **Pattern Guide**, and then press the [↵] button.
- (2) Select **On**, and then press the [↵] button.
- (3) Press the [Esc] button.

7 Set **Top Edge**, **Bottom Edge**, **Left Edge**, or **Right Edge** according to the parts of the image that are overlapped.

The following shows how to set screen (1) as an example.

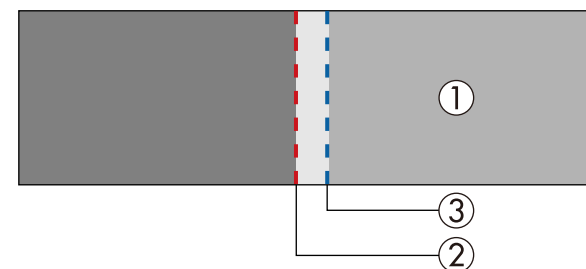

In the example above, you need to adjust the **Left Edge** because you can see the overlapping areas on the left side of the image (1).

- (1) Select **Left Edge**, and then press the [↵] button.
- (2) Select **Blending**, and then press the [↵] button.
- (3) Select **On**, and then press the [↵] button.
- (4) Press the [Esc] button.
- (5) In **Blend Start Position**, align the blending start position with the edge (2) of the image.
- (6) Press the [Esc] button.
- (7) In **Blend Range**, adjust the range (3) to be shaded.
The value for when the overlapped range and the guide are in the same position is the best.
- (8) In **Blend Curve**, adjust how to apply shading.
- (9) Press the [Esc] button.

- 8** After the settings are complete, set **Line Guide** and **Pattern Guide** to **Off** to finish.

Black Level

When a black image is displayed, only areas where the images overlap stands out. The black level function allows you to match the brightness and tone for areas where the images do not overlap with areas where the images overlap, to make the difference less noticeable.

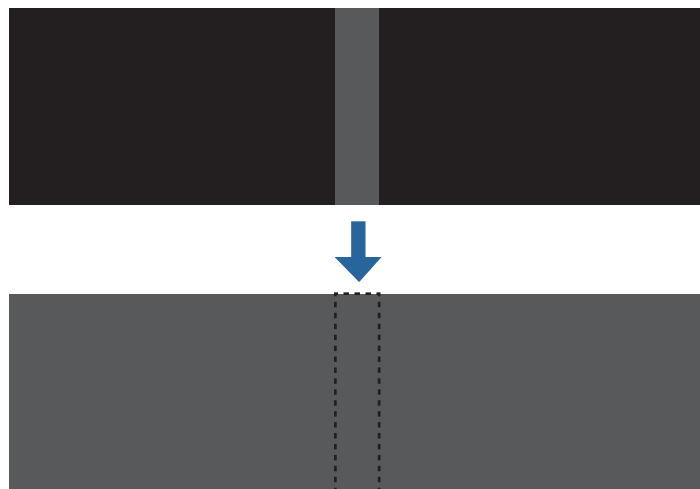

- You cannot adjust the Black Level when a test pattern is displayed.
- If the **Geometry Correction** value is large, you may not be able to adjust correctly.
- The brightness and tone may differ in areas where the images overlap as well as in other areas even after performing black level adjustment.
- If you change the **Top Edge/Bottom Edge/Right Edge/Left Edge** setting, the Black Level is returned to its default value.
 - ☛ "Edge Blending" [p.90](#)
- When auto adjustment starts for Screen Matching, the settings for Color Adjustment are automatically adjusted.
 - ☛ "Automatically correct the brightness and tint for multiple projectors" [p.95](#)

1 Select **Black Level** from **Multi-Projection**, and then press the [↵] button.

2 Select **Color Adjustment**, and then press the [↵] button.
The areas are displayed based on the settings for **Top Edge/Bottom Edge/Right Edge/Left Edge**.

3 Select the area you want to adjust, and then press the [↵] button.
The selected area is displayed in orange.



When multiple screens are overlapping, adjust based on the area with the most overlap (the brightest area). In the illustration below, first align (2) with (1), and then adjust so that (3) aligns with (2).

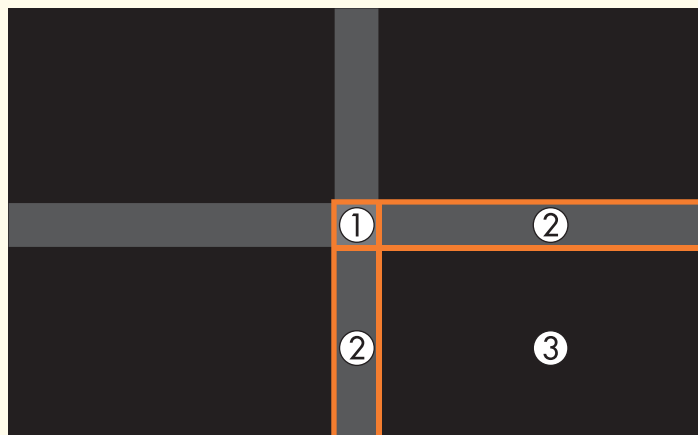

4 Adjust the black tone and brightness.

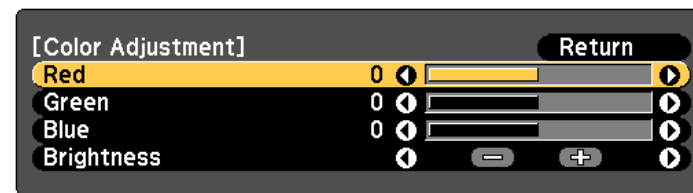

[Esc] :Return [◆]:Select [↔]:Adjust [Menu]:Exit
[Default] :Reset

5 Repeat steps 3 and 4 as needed to adjust any remaining parts.

6 To complete the adjustment, press the [Menu] button.

Area Correction

If there are areas where the color does not match after adjusting the Black Level, adjust individually in **Area Correction**.

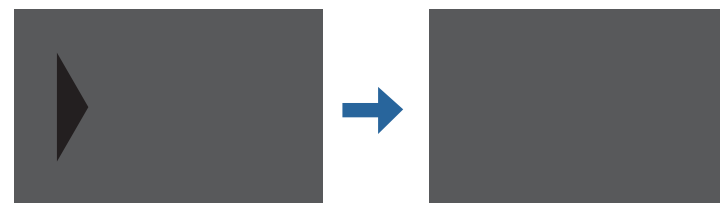

1 Select **Black Level** from **Area Correction**, and then press the [↵] button.

2 Select **Start Adjustments**, and then press the [↵] button.
Boundary lines that indicate areas where images overlap are displayed.

The boundary lines are displayed based on the settings for **Top Edge/Bottom Edge/Right Edge/Left Edge**.

- 3** Use the [▲][▼][◀][▶] buttons to select a boundary line of the area you want to adjust.

The selected line is displayed in orange.



- 4** Press the [↵] button to confirm the selection.

- 5** Use the [▲][▼][◀][▶] buttons to adjust the boundary line positions, and then press the [↵] button.

- 6** Press the [▲][▼][◀][▶] buttons to select the point you want to move, and then press the [↵] button.

The selected point is displayed in orange.

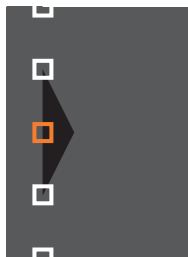

- 7** Press the [▲][▼][◀][▶] buttons to move the point.

To continue to move another point, press the [Esc] button to return to step 6, and then repeat steps 6 and 7.

To adjust another boundary line, press the [Esc] button until the screen for selecting a boundary line from step 3 is displayed.



To return **Black Level** to its default value, press the [Esc] button to return to the screen from step 1, select [Reset], and then press the [↵] button.

- 8** To complete the adjustment, press the [Menu] button.

Screen Matching

Adjust the tint and brightness for multiple projectors.

When projectors are connected to a network, the tint and brightness for multiple projectors are automatically adjusted based on the darkest projector.

When projectors are not connected to a network, or if auto adjustment does not work, you can adjust the tint and brightness for all projectors manually.



- We recommend performing Screen Matching at least 30 minutes after turning on the projector or canceling the shutter function.
- To increase the accuracy of adjustments, we recommend darkening the room while projecting images and then making adjustments.
- Perform the following on the master projector before starting adjustments.
 - Set the **Color Mode** to **Multi-Projection**.
 - Release the shutter.
 - Adjust the following items on the Image menu as necessary. Brightness, Contrast, Color Saturation, Tint, White Balance, Advanced
 - ☛ "Image Menu" [p.137](#)
 - Set the brightness of the projected image.
 - ☛ "Setting the Brightness" [p.77](#)
- When there are large differences in the brightness for each projector due to aging light sources, perform Screen Matching again.
- See the following if Screen Matching does not work correctly.
 - ☛ "Automatic adjustments are not performed correctly" [p.195](#)



- Auto adjustment is not available when using the following lenses. ELPLX02, ELPLX02W, ELPLU02, ELPLU03, ELPLU03S, ELPLU04, ELPLL07, ELPLL08, ELPLR04
- After auto adjustment, lens shift may not work for some lenses.
 - ☛ "Adjusting the Position of the Projected Image (Lens Shift Adjustment)" [p.38](#)

Automatically correct the brightness and tint for multiple projectors

The brightness and tint for the arranged images are adjusted automatically based on the darkest projector.



- Check the following before starting auto adjustment.
 - The projector is connected to the network
 - The **Location Setup** for the projector has already been set
 - The **Brightness Level** is set to the maximum for all projectors
 - ☛ **Settings - Brightness Settings - Light Source Mode, Brightness Level** [p.141](#)
- Auto adjustment is performed using the camera built into the front of the projector. Do not block the camera or the projected images.
- The time necessary for auto adjustment varies according to the location and number of projectors and can take up to approximately 17 minutes.
- Settings are auto adjusted for Brightness Settings, Black Level (**Color Adjustment** only), and Blend Curve.
- After making automatic adjustments, Color Uniformity and Color Matching are returned to their defaults.
- After performing auto adjustment, Light Source Control is set to Off.
- You can schedule this from **Schedule Settings**.

Operating conditions for auto adjustment functions

The auto adjustment functions for Screen Matching are enabled when the following conditions are met.

- The screen surface is flat and not skewed or warped
- Using a matte white diffusion screen
- The projection size is 100 to 300 inches
- The projected image after tiling is rectangular
- There are no gaps between projected images (or part of the images overlap)
- The projector is setup parallel to the projection surface
- The blend width for edge blending is 15 to 45%
- All projectors have the same model number

1 Select **Screen Matching** from **Multi-Projection**, and then press the [**↵**] button.

2 Select **Start Auto Adjustment**, and then press the [**↵**] button.

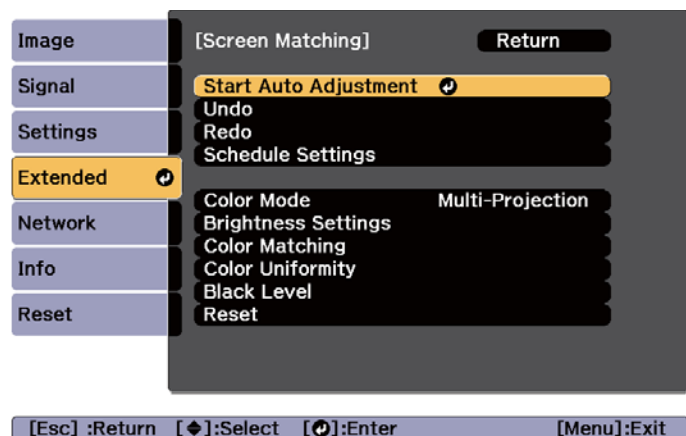

When a message is displayed, select **Yes**. The adjustment pattern is displayed, and adjustment starts. If the projected image is displayed before the adjusting, the procedure is complete.



- See the following if an error occurs.
 - ☛ "Automatic adjustments are not performed correctly" [p.195](#)
- To return to the status before auto adjustment, select **Undo**. When you select **Redo** after selecting **Undo**, it returns the image to the status after auto adjustment.
- When you use the ELPLW05 and the amount of lens shift is too large, the brightness may not be corrected properly. Adjust the **Light Source Mode** manually.
 - ☛ "Setting the Brightness" [p.77](#)
- If the amount of blend width or lens shift is too large, blend curve may not be corrected properly. Adjust the **Blend Curve** manually.
 - ☛ "Edge Blending" [p.90](#)
- To return **Screen Matching** to its default value, select **Reset**.

Color Matching

You can fine tune the color balance and brightness from black to white for each color tone.

When the projectors are not connected to a network, or if you want to adjust manually after the automatic adjustments, perform the following steps on all projectors.

1 Select **Screen Matching** from **Multi-Projection**, and then press the [**↵**] button.

2 Select **Color Matching**, and then press the [**↵**] button.
The following screen is displayed.

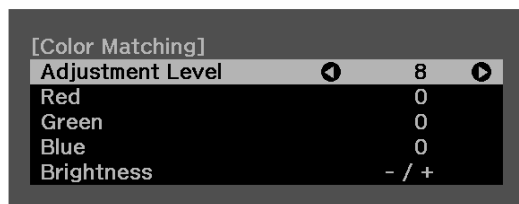

[↵]: Switch Background

Half of the overlapped area is displayed in black so that it is easy to check the edge of the image.

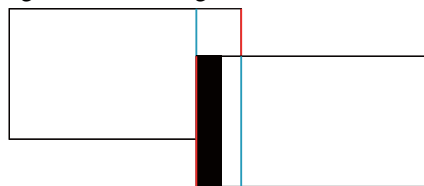

Adjustment Level: There are eight levels from white, through gray, and up to black. You can adjust each level individually.

Red, Green, Blue: Adjusts the tone for each color.

Brightness: Adjusts the image brightness.



Whenever the [↵] button is pressed, the screen changes between the projected image and the adjustment screen.

- 3** Select **Adjustment Level**, and then use the [◀][▶] buttons to set the adjustment level.
- 4** Select **Red**, **Green**, or **Blue**, and then press the [◀][▶] buttons to adjust the color tone.
- 5** Select **Brightness**, and then use the [◀][▶] buttons to adjust the brightness.

- 6** Return to step 2 and adjust each level.
- 7** Press the [Esc] button to return to the previous screen.

Displaying a Scaled Image

A section of the image is cropped and displayed. This allows you to create one large image by combining images projected from multiple projectors.

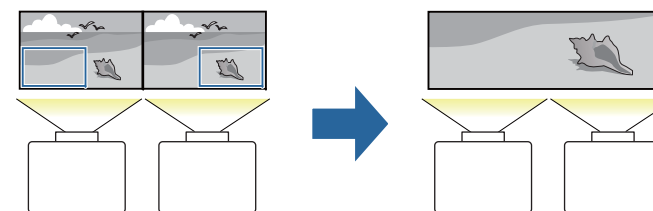

- 1** Project the image, and then press the [Menu] button.
- 2** Select **Multi-Projection** from **Extended**.



You can also perform the same operation from **Scale** in **Signal**.

- 3** Select **Scale**, and then press the [↵] button.
- 4** Turn on **Scale**.
 - (1) Select **Scale**, and then press the [↵] button.
 - (2) Select **Auto** or **Manual**, and then press the [↵] button.

Auto: Automatically adjusts the clipped area according to the adjustment values in Edge Blending and Tiling. You do not need to perform any steps after step 6.

Manual: Allows you to adjust the clipped area manually.
 - (3) Press the [Esc] button to return to the previous screen.



If auto adjustment does not work for the clipped image, adjust the aspect ratio, and then select **Auto**.
 ☞ "Changing the Aspect Ratio of the Projected Image" p.80

5 Set **Scale Mode**.

- (1) Select **Scale Mode**, and then press the [**↶**] button.
- (2) Select **Zoom Display** or **Full Display**, and then press the [**↶**] button.

Zoom Display: Adjusts according to the image currently displayed.

Enlarge

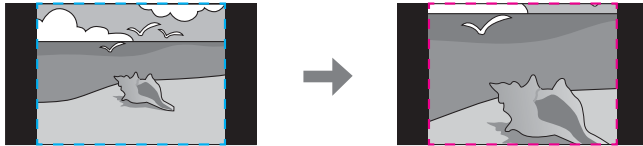

Move



Full Display: Adjusts according to the projector's panel size (the maximum area in which an image can be displayed).

Enlarge



Move



- (3) Press the [Esc] button to return to the previous screen.

6 Adjust the scale.

Select the adjustment method with the [**▲**][**▼**] buttons, then adjust using the [**◀**][**▶**] buttons. (Minimum magnification of 0.5 to maximum magnification of 10)

-+: Enlarges or reduces an image horizontally and vertically at the same time.

Scale Vertically: Enlarges or reduces an image vertically.

Scale Horizontally: Enlarges or reduces an image horizontally.

7 The image is clipped and adjusted.

- (1) Select **Clip Adjustment**, and then press the [**↶**] button.
 If you select **Clip Range**, the range and coordinates of the image that the projector will project is displayed.
- (2) Use the [**▲**], [**▼**], [**◀**], and [**▶**] buttons to scroll the image.
 Adjust the coordinates and size of each image while viewing the screen.
- (3) Press the [Menu] button to finish making settings.



You can check the displayed area after clipping for the entire image from **Clip Range**.

Tiling Assist

By using the projector's built-in camera and the Edge Blending feature, you can create a seamless image by automatically adjusting the pixel position in overlapping areas of the image.

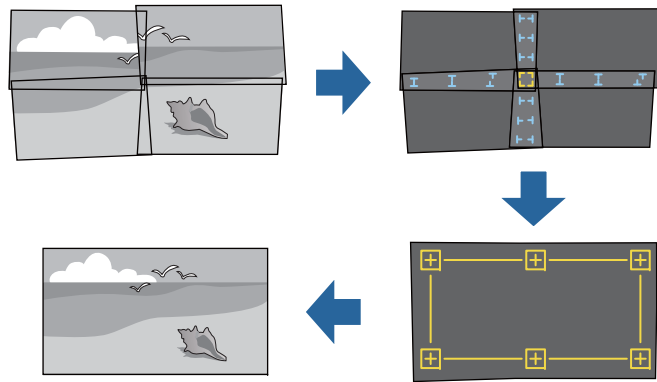

You can run Tiling Assist from Epson Projector Professional Tool (version 1.20 or later). Download the software from the following Web site.

<http://www.epson.com>

Operating conditions for auto adjustment functions

Tiling Assist works under the following conditions:

- The screen surface is flat and not skewed or warped
- Using a matte white diffusion screen
- The projection size is 100 to 300 inches
- The projected image after tiling is rectangular
- Parts of all projected images are overlapping
- The projector is setup parallel to the projection surface
- The blend width for edge blending is 15 to 43%
- All projectors have the same model number



- We recommend performing Tiling Assist at least 30 minutes after turning on the projector or canceling the shutter function.
- To increase the accuracy of adjustments, we recommend darkening the room while projecting images and then making adjustments.
- Auto adjustment is not available when using the following lenses. ELPLX02, ELPLX02W, ELPLU02, ELPLU03, ELPLU03S, ELPLU04, ELPLL07, ELPLL08, ELPLR04
- Check the following before starting auto adjustment.
 - The projector is connected to the network
 - The projector has been configured in Epson Projector Professional Tool
- Auto adjustment is performed using the camera built into the front of the projector. Do not block the camera or the projected images.
- The time necessary for auto adjustment varies according to the location and number of projectors and can take up to approximately 6 minutes.
- The settings for Point Correction and Black Level are corrected automatically.

Projecting Two Images Simultaneously (Split Screen)

You can simultaneously project images from two sources on the right and left of the screen.

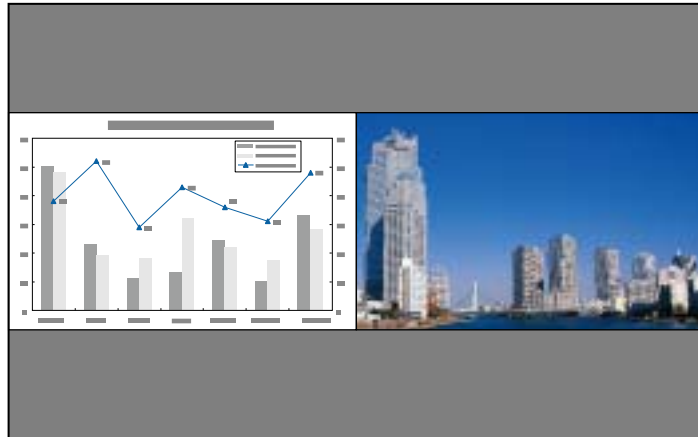

Combinations of sources that cannot project in split screen

Split screen is not available for the following combination of sources.



See the *Specifications* for more details on input source combinations. You can download the information from the following Web site.

<http://epson.sn>

- Computer and LAN
- SDI and SDI
- Sources with ports on the same interface board (for example: HDMI and DVI-D for Slot1)

Operating procedures

Projecting on a split screen

- 1 Press the [Menu] button while projecting.
- 2 Select **Split Screen** from **Settings**.
The currently selected input source is projected on the left of the screen.
- 3 Press the [Menu] button.
The Split Screen Setup screen is displayed.

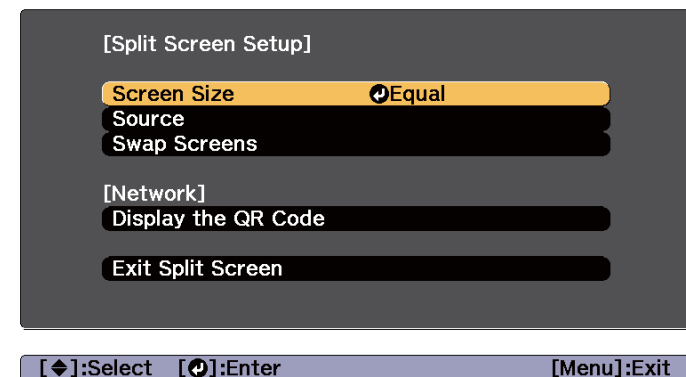

- 4 Select **Source**, and then press the [**Left Arrow**] button.
- 5 Select each input source for **Left** and **Right**.

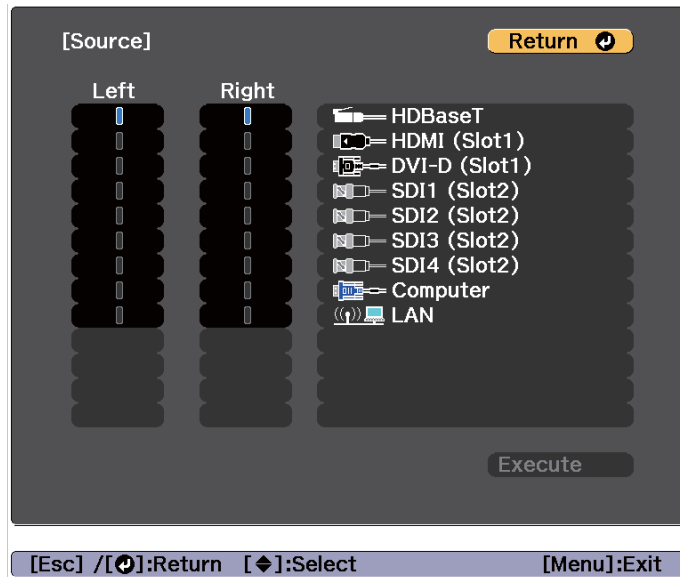

You can perform the same operations using the following procedure.

➡ "Changing the Projected Image" [p.62](#)

- 6 Select **Execute**, and then press the [↵] button.

To switch the source during split screen projection, start the procedure from step 3.

Switching the left and right screens

Use the following procedure to switch the projected images displayed on the left and right screens.

- 1 Press the [Menu] button during split screen projection.

- 2 Select **Swap Screens**, and then press the [↵] button.
The projected images on the left and right are swapped.

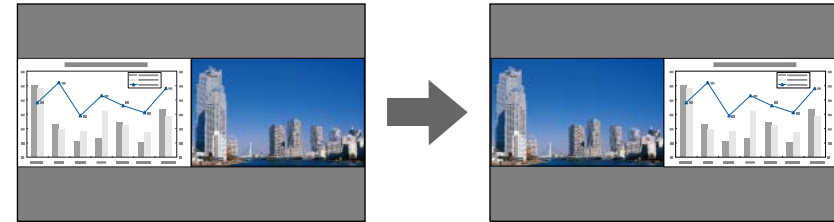

Switching the left and right image sizes

- 1 Press the [Menu] button during split screen projection.
- 2 Select the **Screen Size**, and then press the [↵] button.
- 3 Select the screen size you want to display, and then press the [↵] button.

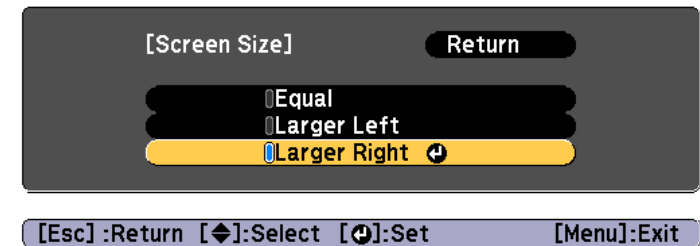

The projected images will appear as shown below after setting the screen size.

Equal

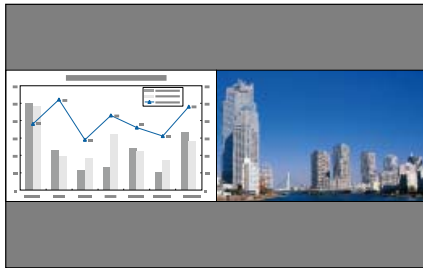

Larger Left

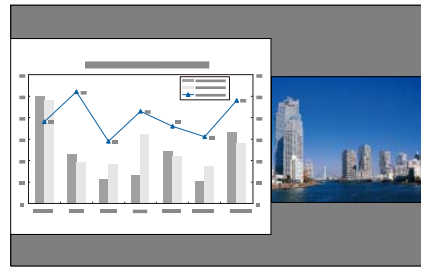

Larger Right

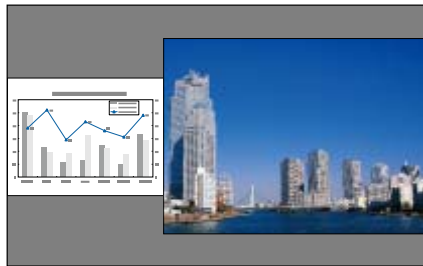

- You cannot enlarge both the left screen and right screen images at the same time.
- When one image is enlarged, the other image is reduced.
- Depending on the video signals that are input, the images on the left and right may not appear to be the same size even if **Equal** is set.

Ending the split screen

Perform one of the following operations to end split screen.

- Press the [Esc] button.
- Select **Exit Split Screen** on the Split Screen Setup screen. p.100

Restrictions during split screen projection

Operating restrictions

The following operations cannot be performed during split screen projection.

- Setting the configuration menu
- Changing the aspect mode
- Using the [User1], [User2], or [User3] button on the remote control

Restriction relating to images

- For the image on the right screen, the default values for the **Image** menu are applied. Adjustments that affect the entire projected image such as **Color Mode** and **Color Temp.** are applied for both left and right images.
- **Deinterlacing** and **Noise Reduction** are only enabled for the left screen.
- The split screen feature supports up to 4k30p signals for DisplayPort. The feature is not available for dual-link.

Hiding the Image Temporarily (Shutter)

When using Shutter, the mechanical shutter closes and projection stops.

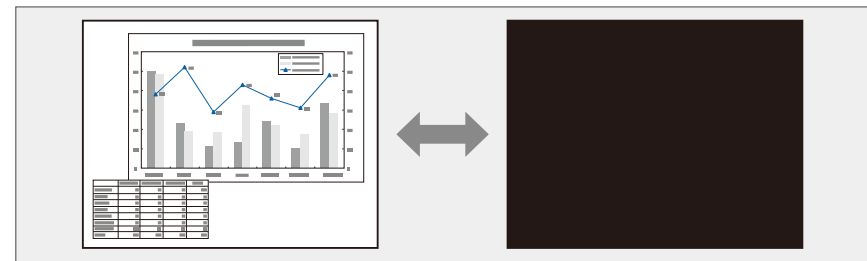

Each time you press the [Shutter] button, the Shutter function turns on or off.

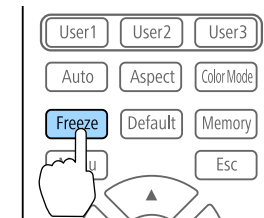
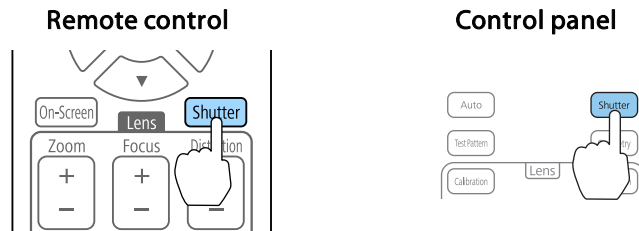

- The light source remains on when using Shutter.
- You can use **Shutter Settings** to set the shutter operations when the projector is turned on/off, and the timing for hiding/displaying images.
 - ☛ **Extended - Operation - Shutter Settings p.143**
- When projecting moving images, the images continue to be played back while the Shutter function is activated. It is not possible to resume projection from the point where the Shutter function was activated.



- When projecting moving images, the images continue to be played back while the screen is frozen. It is not possible to resume projection from the point where the screen was frozen.
- If the [Freeze] button is pressed while the Configuration menu or the Help screen is displayed, the menu or the Help screen that is displayed is closed.

Freezing the Image (Freeze)

When Freeze is activated on moving images, the frozen image continues to project on the screen, so you can project a moving image one frame at a time like a still photo. Also, you can perform operations such as changing between files during presentations from a computer without projecting any images if the Freeze function is activated beforehand.

Each time you press the [Freeze] button on the remote control, Freeze turns on or off.

Saving a User's Logo

You can save the image that is currently being projected as a User's Logo.



- When **User's Logo Protection** from **Password Protection** is set to **On**, a message is displayed and the User's Logo cannot be changed. Perform operations after setting **User's Logo Protection** to **Off**.
 "Managing Users (Password Protection)" [p.111](#)
- If you use the batch setup function to copy menu settings between multiple projectors, the User's Logo is also copied. Do not set images that you do not want to share across multiple projectors as the User's Logo.
- A User's Logo is registered according to the projector's panel resolution as follows.
 - If the input resolution is higher than the panel resolution, part of the input image is registered.
 - If the input resolution is lower than the panel resolution, the image is registered using the native view of the input image and displayed in the center.
- You cannot save images from the DisplayPort In port as the User's Logo.

1 Project the image you want to save as the User's Logo, and then press the [Menu] button.

 "Configuration Menu Operations" [p.132](#)

2 Select **User's Logo** from **Extended**.



When you select **User's Logo**, settings such as Geometry Correction, Aspect, Scale, and Screen Type are temporarily disabled.

3 Select **Start Setting**, and then press the [↵] button.

The confirmation screen is displayed.

4 Select **Yes**, and then press the [↵] button.

The size selection screen is displayed.

5

Select the user's logo size, and then press the [↵] button.

6

When the message "Save this image as the User's Logo?" is displayed, select **Yes**.

The image is saved. After the image has been saved, the message "Completed." is displayed.



- Select **Reset** to delete the image you registered and return to the default settings.
- The time it takes to save the user's logo depends on the selected size; it takes approximately 16 minutes for **Full Screen** and approximately 4 minutes for **1920x1080**. Select **Cancel** to stop saving.
- You can also register a User's Logo from your Web browser. You can upload the following types of images as logo data from **Initial Setting** on the **Advanced** screen in Epson Web Control.
 - Format: PNG
 - Size: Up to 10 MB
 - Color depth: 24-bit (Transparency is not supported; the User's Logo is saved and displayed as a 16-bit image)
 - Recommended resolution: 1920 x 1080 (Depending on the aspect ratio of the image, black bars are displayed at the top and bottom or left and right for images outside the recommended resolution, and the images are displayed according to the 1920 x 1080 resolution.)
-  "Displaying the Epson Web Control Screen" [p.214](#)

The settings for the image currently displayed and values for geometry correction are saved as a memory, allowing you to load them when necessary.

Saving/Loading/Erasing/Resetting the Memory

- 1 Press the [Memory] button while projecting.

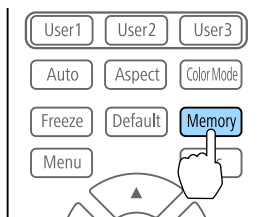

You can also operate from the Configuration menu.

☛ Settings - Memory p.141

- 2 Select a memory type, and then press the [↵] button.

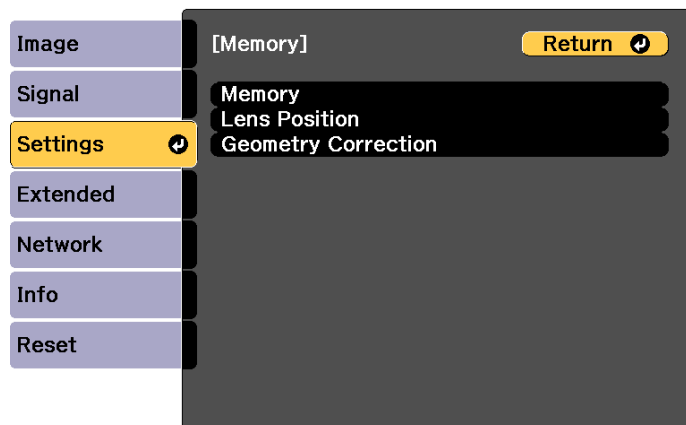

[Esc] / [⏏]:Return [◆]:Select [Menu]:Exit

Memory: Settings for the following menu items are saved in the memory. You can register up to 10 values.

Top Menu	Submenu
Image	All setting items
Signal	Overscan Video Range Scale
Settings	Brightness Settings
Extended	Edge Blending Black Level Color Matching

Lens Position: Registers the position of the lens adjusted using lens shift, zoom, focus, and distortion. You can register up to 10 values.
☛ "Registering and Loading Lens Adjustment Values" p.43

Geometry Correction: Adjustment value of the geometry correction is saved. You can register up to 3 values.

- 3 Select the function you want to perform, then press the [↵] button.

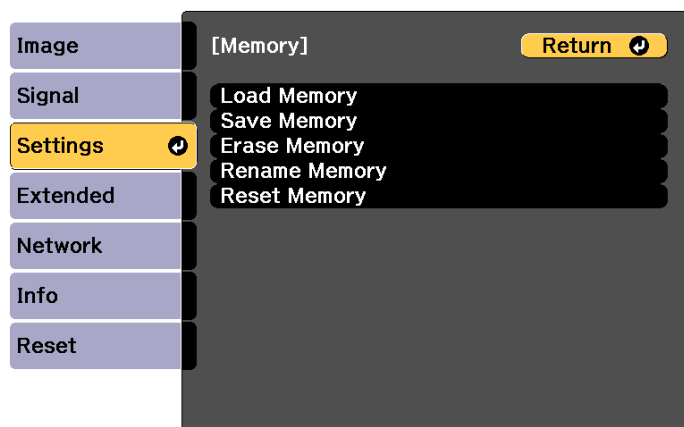

[Esc] / [Return]:Return [Left Arrow]:Select [Menu]:Exit

Function	Explanation
Load Memory	Loads the saved memory. When you select a memory and press the [Left Arrow] button, the settings applied to the current image are replaced with the settings from the memory.
Save Memory	Registers current settings in the memory. When you select a memory name and press the [Left Arrow] button, the settings are saved.
Erase Memory	Erases the registered memory. When you select a memory name and press the [Left Arrow] button, a message is displayed. Select Yes , and then press the [Left Arrow] button to erase the selected memory.
Rename Memory	Changes the memory name. Select the memory name you want to change, and then press the [Left Arrow] button. Enter the memory name using the soft keyboard. ☛ "Soft keyboard operations" p.150 When you have finished, move the cursor over Finish , and then press the [Left Arrow] button.

Function	Explanation
Reset Memory	Resets the name and settings of a saved memory. To reset all memories saved in Memory , Lens Position , and Geometry Correction , use Reset All Memories . ☛ Reset - Reset All Memories p.159



If the mark on the left of the memory name is turned blue, it means the memory has already been registered. When you select a registered memory, a message is displayed asking you to confirm that you want to overwrite the memory. If you select **Yes**, the previous settings are deleted and the current settings are registered.

You can schedule turning the projector power on/off and switching the input source, as events in the schedule. Registered events are executed automatically at the specified time on the specified dates or weekly. You can register up to 30 events in **Schedule**, and one event in **Extended Schedule**.

Saving an Event

Setting an Event

- 1 Press the [Menu] button while projecting.
 ☞ "Configuration Menu Operations" [p.132](#)
- 2 Select **Schedule Settings** from **Extended**.
- 3 Select **Add New** from **Schedule** or **Extended Schedule**.

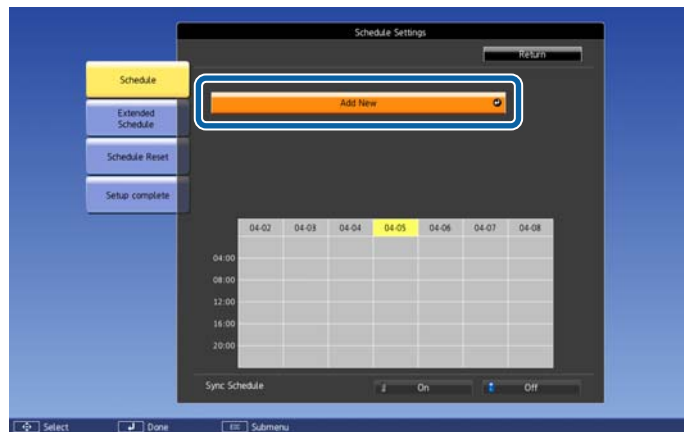

- 4 Set the schedule.

Submenu Name	Function
Event Settings	Select an operation of the projector when the event is executed. Select No Change for items that you do not want to change when the event occurs. You can set the following item operations. Schedule <ul style="list-style-type: none"> • Power • Source • Light Source Mode • Shutter • Light Source Calibration Extended Schedule <ul style="list-style-type: none"> • Color Calibration • Screen Matching
Date / Time Settings	Set the date, day of the week, and time to execute the event. Use the soft keyboard to enter the date and time. ☞ "Soft keyboard operations" p.150

- 5 Select **Save**, and then press the [**↩**] button.

To register additional events, repeat steps 3 to 5.



Make sure you perform Screen Matching after executing Light Source Calibration.

- 6 When you have set Light Source Calibration or Screen Matching events and you want to apply this schedule to other projectors with tiling settings, set **Sync Schedule** to **On**.

- 7 Select **Setup complete**, and then select **Yes** to finish saving.



- Light source calibration does not start automatically when the projector is used continuously for more than 24 hours, or when direct shutdown is used regularly. Set **Light Source Calibration** to enable this function after every 100 hours of usage.
- You cannot register a schedule in which Schedule events conflict with an Extended Schedule event.
- You cannot set other events before the following times.
 - Five minutes before or after executing a Color Calibration event.
 - Five minutes before and 30 minutes after executing a Screen Matching event.







Checking an Event

This section explains how to check a Schedule event.

- 1** Press the [Menu] button while projecting.
- 2** Select **Schedule Settings** from **Extended**.

- Press the [◀][▶] buttons to highlight the date you want to check. The details of the events registered on the selected date are displayed. The indicator turns on when an event is saved.



-  (Blue): Enabled event
-  (Gray): Disabled event
-  : Regular event
-  (Aqua): Single event
-  (Orange): Regular event
-  (Green): Communication monitoring On/Off
-  (Gray): Disabled event

Editing an Event

- Press the [Menu] button while projecting.
 "Configuration Menu Operations" p.132
- Select **Schedule Settings** from **Extended**.

- Use the [◀][▶] buttons to highlight the date containing the event you want to edit.

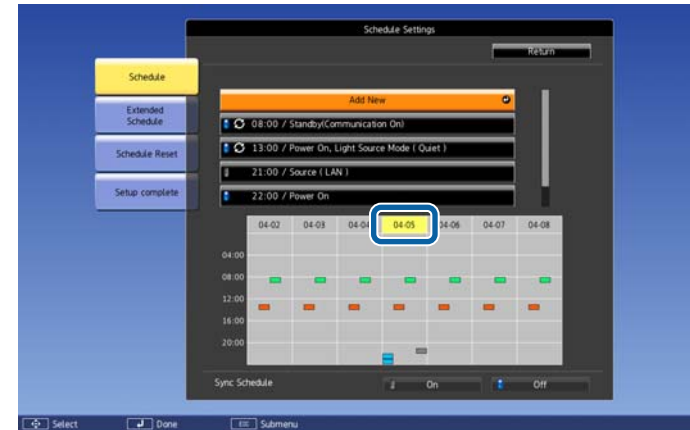

- Highlight the event you want to edit, and then press the [Esc] button.

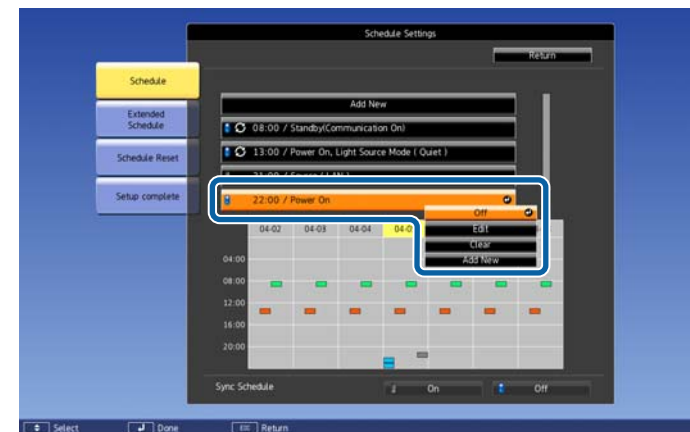

5 Edit the event.

Submenu Name	Function
On/Off	Enable or disable the selected event.
Edit	Edits the content of the selected event. Select Save , and then press the [↵] button to complete the editing.
Clear	Deletes the selected event.
Add New	Saves a new event. Select Save , and then press the [↵] button to complete registering.

6 Select **Setup complete**, and then select **Yes** to finish editing.



To delete all registered events, select **Schedule Reset**, and then select **Yes**. Select **Setup complete**, and then select **Yes** to delete the events.

The projector has the following enhanced security functions.

- **Password Protection**
You can limit who can use the projector.
- **Control Panel Lock/Remote Control Button Lock**
You can prevent people changing the settings on the projector without permission.
☛ "Restricting Operation" p.113

Managing Users (Password Protection)

When Password Protection is activated, people who do not know the password cannot use the projector to project images even if the projector power is on. Furthermore, the user's logo that is displayed when you turn on the projector cannot be changed. This acts as an anti-theft function as the projector cannot be used even if it is stolen. At the time of purchase, Password Protection is not activated.

Kinds of Password Protection

The following five types of Password Protect settings can be made according to how the projector is being used.

- **Power On Protection**
When **Power On Protection** is **On**, you need to enter a preset password after the projector is plugged in and turned on (this also applies to Direct Power On). If the correct password is not entered, projection does not start.

- **User's Logo Protection**

Even if someone tries to change the User's Logo set by the owner of the projector, it cannot be changed. When **User's Logo Protection** is set to **On**, the following setting changes for the User's Logo are prohibited.

- Capturing a User's Logo
- Setting **Display Background** or **Startup Screen** from **Display**
☛ **Extended - Display** p.143

- **Network Protection**

When **Network Protection** is set to **On**, changing the settings for **Network** is prohibited.

☛ "Network Menu" p.148

- **Schedule Protection**

When **Schedule Protection** is set to **On**, changing settings for the projector's system time or schedules is prohibited.

- **Remote Camera Access**

When **Remote Camera Access** is set to **On**, changing the settings for **Remote Camera Access** menu in the **Network** menu can be prohibited. The default is **On**.

Setting Password Protection

Use the following procedure to set Password Protect.

- 1 During projection, hold down the [Freeze] button on the remote control for about five seconds.

The Password Protection setting menu is displayed.

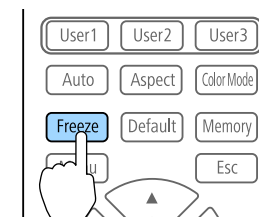



If Password Protection is already activated, you must enter the password.
If the password is entered correctly, the Password Protection setting menu is displayed.

☞ "Entering the password" [p.112](#)

- 2 Select the type of Password Protect you want to set, and then press the [**↵**] button.

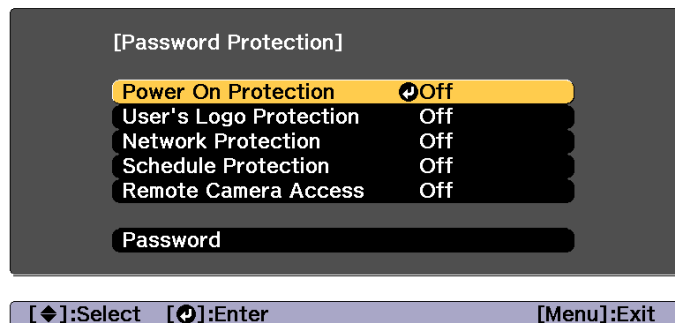

- 3 Select **On**, and then press the [**↵**] button.
Press the [Esc] button to return to the screen in step 2.

- 4 Set the password.
 - (1) Select **Password**, and then press the [**↵**] button.
 - (2) When the message "Change the password?" is displayed, select **Yes** and then press the [**↵**] button. The default password is set to "0000". Change this to your own desired password. If you select **No**, the screen displayed in step 2 is displayed again.
 - (3) While holding down the [Num] button, enter a four digit number using the numeric buttons. The number entered is displayed as "* * * *". When you enter the fourth digit, the confirmation screen is displayed.

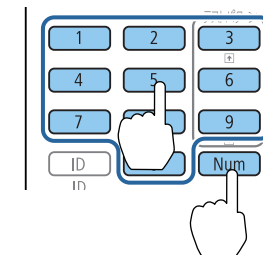

- (4) Re-enter the password.
When the message "Password accepted." is displayed.
If you enter the password incorrectly, a message is displayed prompting you to re-enter the password.

Entering the password

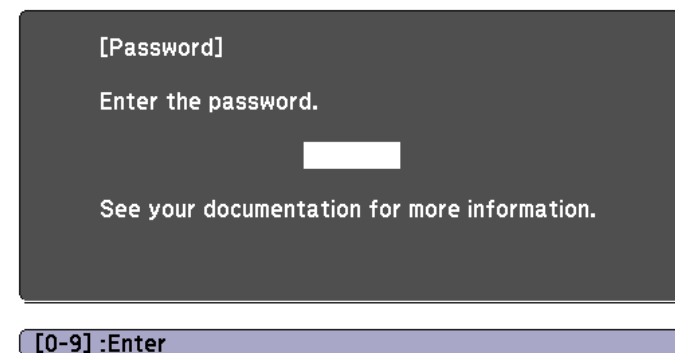

When the password entry screen is displayed, enter the password using the remote control.

While holding down the [Num] button, enter the password by pressing the numeric buttons.



When you enter the correct password, Password Protect is temporarily released.

Attention

- If an incorrect password is entered three times in succession, the message "The projector's operation will be locked." is displayed for approximately five minutes, and then the projector switches to standby mode. If this happens, disconnect the power plug from the electrical outlet and then reinsert it and turn the projector's power back on. The projector displays the password entry screen again so that you can enter the correct password.
- If you have forgotten the password, make a note of the "Request Code: xxxxx" number that appears on the screen and contact the nearest address provided in the Epson Projector Contact List.
 [Epson Projector Contact List](#)
- If you continue to repeat the above operation and input the wrong password thirty times in succession, the following message is displayed and the projector does not accept any more password entries. "The projector's operation will be locked. Contact your nearest Epson service center."
 [Epson Projector Contact List](#)

Restricting Operation

The following three kinds of operation restriction functions are available with the projector.

- **Control Panel Lock**
This is useful at events or shows when you want to deactivate all buttons during projection or at schools when you want to limit button operation.
- **Lens Lock**
This function deactivates all buttons on the remote control related to the lens operation to prevent improper lens adjustment after it is properly adjusted.
- **Remote control button lock**
This function deactivates buttons except for main buttons needed for basic remote control operation, to prevent mistakes in operations.

Control Panel Lock

Perform one of the following to lock the operation buttons on the control panel. Even if the control panel is locked, you can still use the remote control as usual.

- **Full Lock**
All of the buttons on the control panel are locked. You cannot perform any operations from the control panel, including turning the power on or off.
- **Partial Lock**
All of the buttons on the control panel, except for the [⏻] button, are locked.

- 1** Press the [🔒] button on the control panel during projection to display the Control Panel Lock screen.



You can also make settings in **Control Panel Lock** from the configuration menu.

 [Settings - Lock Setting - Control Panel Lock p.141](#)

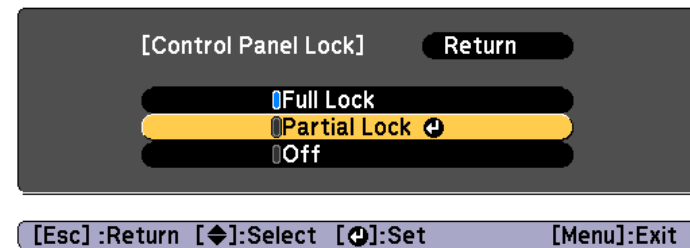

- 2** Select either **Full Lock** or **Partial Lock** according to your purpose.



- 3** Select **Yes** when the confirmation message is displayed.
The control panel buttons are locked according to the setting you chose.



You can release the control panel lock by one of the following two methods.

- Use the remote control to set **Control Panel Lock** to **Off** from the configuration menu.
 - ☛ **Settings - Lock Setting - Control Panel Lock** [p.141](#)
- Press and hold down the [] button or the [] button on the control panel for about seven seconds, a message is displayed and the lock is released.

Lens Lock

This function locks the following buttons on the remote control related to the lens operation.

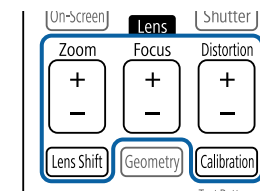

Set the **Lens Lock** to **On** in the Configuration menu.

- ☛ **Settings - Lock Setting - Lens Lock** [p.141](#)

Remote control button lock

This function locks the following buttons on the remote control.

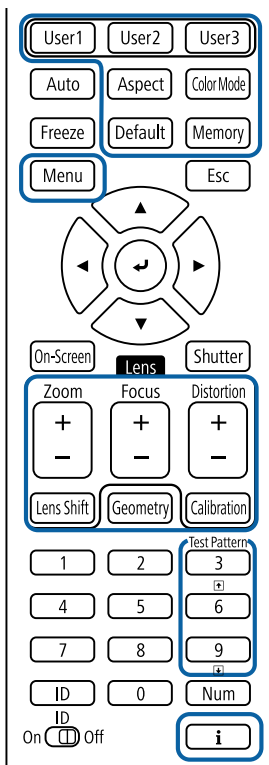

Even if the remote control button lock is on, the following operations are possible.

- Resetting default for the Remote Receiver setting
- Releasing the remote control button lock

Each time the [i] button is pressed for approximately 5 seconds, the remote control button lock turns on or off.

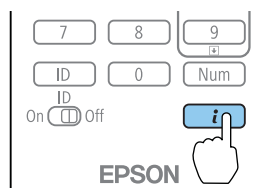



Using the Projector on a Network

Follow the instructions in these sections to set up your projector for use on a network.

You can send images to your projector through a wired network. To do this, connect the projector to your network, and then set up your projector and computer for network projection.

After connecting and setting up the projector, install Epson iProjection from the EPSON Projector Software CD-ROM (if available) or Web site.

Epson iProjection software sets up your computer for network projection. It also allows you to hold interactive meetings by projecting user's computer screens over a network. See the "Epson iProjection Operation Guide (Windows/Mac)" for instructions.

Selecting Wired Network Settings

Before you can project from computers on your network, you need to select network settings on the projector.



Make sure you already connected the projector to your wired network using the LAN port.

☛ "Connecting a LAN Cable" [p.56](#)

- 1 Press the [Menu] button on the control panel or remote control.
- 2 Select the **Network** menu and press [Enter].
- 3 Select **Network Configuration** and press [Enter].

- 4 Select the **Basic** menu and press [Enter].

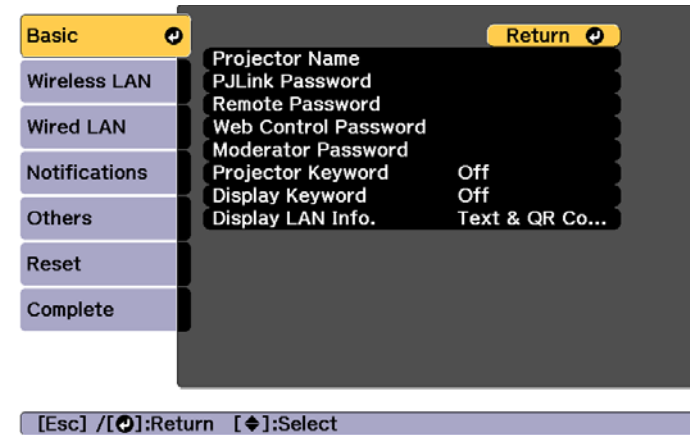

- 5 Select the basic options as necessary.
☛ "Basic menu" [p.150](#)



Use the displayed keyboard to enter the name, passwords and keyword. Press [▲][▼][◀][▶] buttons on the remote control to highlight characters and press [Enter] to select them.

6 Select the **Wired LAN** menu and press [Enter].

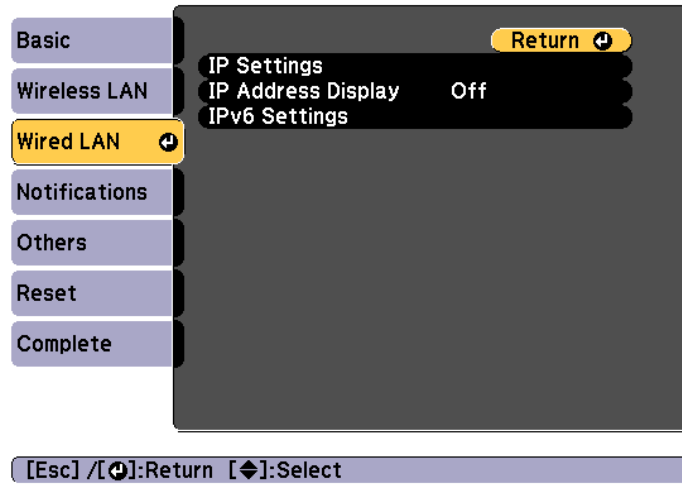

7 Assign the IP settings for your network as necessary.

- If your network assigns addresses automatically, select **IP Settings** to set the **DHCP** setting to **On**.
- If you must set addresses manually, select **IP Settings** to set the **DHCP** setting to **Off**, and then enter the projector's **IP Address**, **Subnet Mask**, and **Gateway Address** as necessary.
- If you want to connect the projector to the network using IPv6, select **IPv6 Settings**.

☞ "Wired LAN menu" [p.155](#)



Press the [▲][▼][◀][▶] buttons on the remote control, and then select the number you want to enter on the soft keyboard displayed. Press the [Enter] button to confirm.

8 To prevent the IP address from being displayed on the LAN standby screen, set the **IP Address Display** setting to **Off**.

9 If you have finished making settings, select **Setup complete**. Follow the on-screen instructions to save the settings and close the menu.

10 Press the [LAN] button on the remote control. The wired network settings complete when you see the correct IP address on the LAN standby screen.

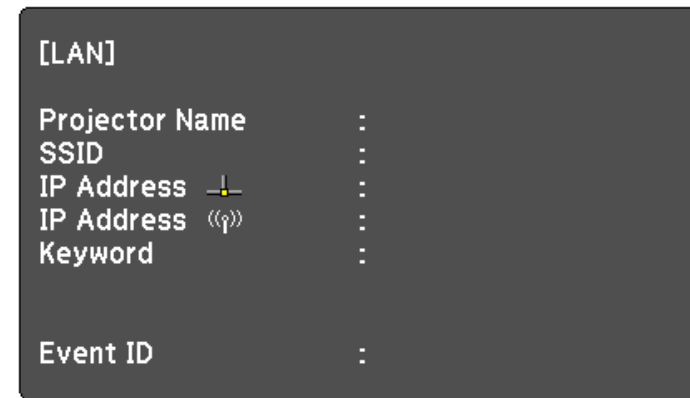

You can use the projector's built-in wireless LAN function to project images from the projector over a wireless network.

When projecting over wireless LAN, make sure you setup wireless LAN for the projector and the computer.

You can connect the projector to your wireless network by configuring the connection manually using the projector's **Network** menus.

Set the projector's time before configuring the Network menu. If the time is not set, the wireless LAN may not be configured correctly.

☛ "Setting the Time" [p.48](#)

After making network settings for the projector, install the network software from the EPSON Projector Software CD-ROM (if available) or the network software downloaded from the Web site. Use the following software and documentation to set up and control wireless projection:

- Epson iProjection (Windows/Mac) software allows you to hold interactive meetings by projecting the computer screens of users over a network. See the "Epson iProjection Operation Guide (Windows/Mac)" for instructions.
- Epson iProjection (iOS/Android) app allows you to project from iOS or Android mobile devices.
You can download Epson iProjection (iOS/Android) for free from the App Store or Google Play. Any fees incurred when communicating with the App Store or Google Play are the responsibility of the customer.
- Epson iProjection (Chromebook) allows you to project images from a Chromebook.
You can download Epson iProjection (Chromebook) for free from the Chrome Web Store. Any fees incurred when communicating with the Chrome Web Store are the responsibility of the customer.

Selecting Wireless Network Settings Manually

Before you can project from your wireless network, you need to select network settings for the projector.

- 1** Press the [Menu] button on the control panel or remote control.
- 2** Select the **Network** menu and press [Enter].
- 3** Set **Wireless Mode** to **Wireless LAN On**.

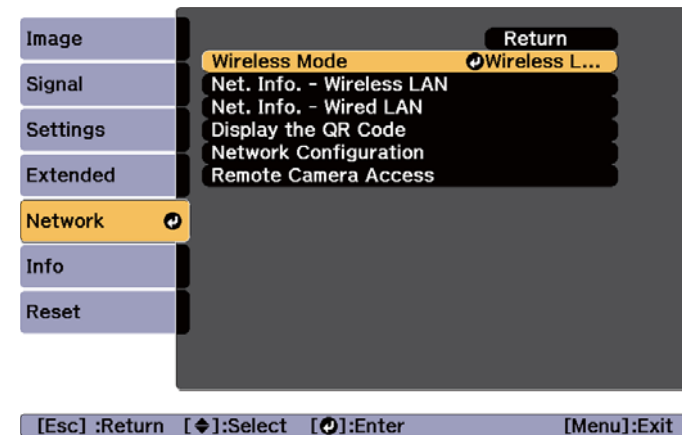

- 4** Select **Network Configuration** and press [Enter].

- 5** Select the **Basic** menu and press [Enter].

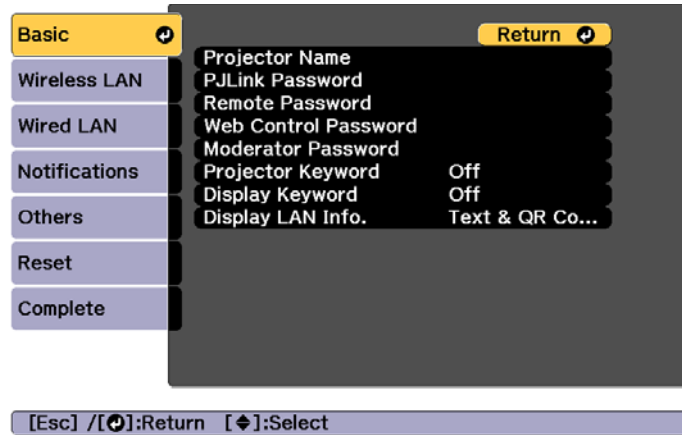

- 6** Select the basic options as necessary.

☛ "Basic menu" p.150



Use the displayed keyboard to enter the name and password. Press [▲][▼][◀][▶] buttons on the remote control to highlight characters and press [Enter] to select them.

- 7** Select the **Wireless LAN** menu and press [Enter].

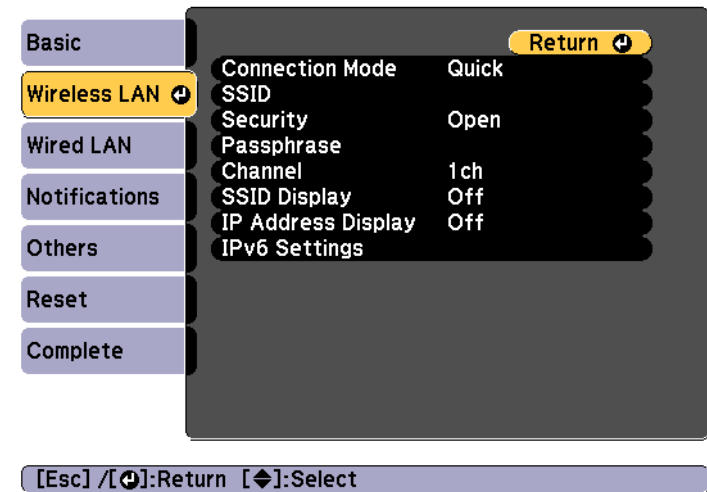

- 8** Select the **Connection Mode** setting.

- **Quick:** Lets you connect to multiple smartphones, tablets, or computers directly using wireless communication.
- **Advanced:** Lets you connect to a smartphone, tablet, or computer over a wireless LAN access point.

- 9** If you selected the **Advanced** connection mode, select **Search Access Point** to select the access point you want to connect to.



If you need to assign the SSID manually, select **SSID** to enter the SSID.

- 10** For the **Advanced** connection mode, assign the IP settings for your network as necessary.

- If your network assigns addresses automatically, select **IP Settings** to set the **DHCP** setting to **On**.

- If you must set addresses manually, select **IP Settings** to set the **DHCP** setting to **Off**, and then enter the projector's **IP Address**, **Subnet Mask**, and **Gateway Address** as necessary.
- If you want to connect the projector to the network using IPv6, select **IPv6 Settings**.

☛ "Wireless LAN menu" [p.151](#)

- 11** To prevent the SSID or IP address from being displayed on the LAN standby screen, set the **SSID Display** setting or the **IP Address Display** setting to **Off**.
- 12** If you have finished making settings, select **Setup complete**. Follow the on-screen instructions to save the settings and close the menu.
- 13** Press the [LAN] button on the remote control.
The wired network settings complete when you see the correct IP address on the LAN standby screen.

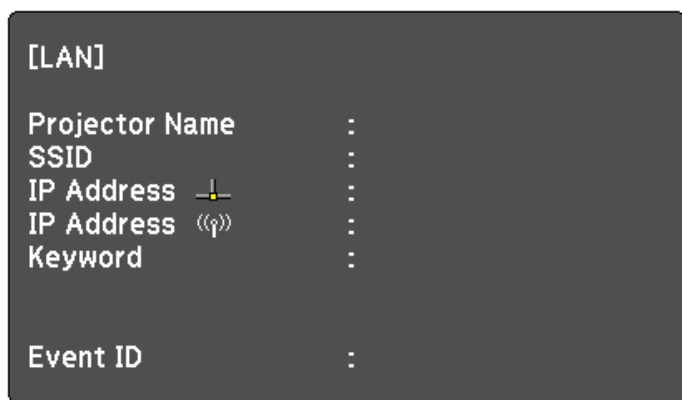

When you have finished making wireless settings for your projector, you need to select the wireless network on your computer. Then start the network software to send images to your projector through a wireless network.

Selecting Wireless Network Settings in Windows

Before connecting to the projector, select the correct wireless network on your computer.

- 1** To access your wireless utility software, double-click the network icon on the Windows taskbar.
- 2** When connecting in Advanced connection mode, select the network name (SSID) of the network the projector is connecting to.
- 3** Click **Connect**.

Selecting Wireless Network Settings in Mac

Before connecting to the projector, select the correct wireless network on your computer.

- 1** Click the AirPort icon on the menu bar at the top of the screen.
- 2** When connecting in Advanced connection mode, make sure AirPort is turned on and select the network name (SSID) of the network the projector is connecting to.

Setting Up Wireless Network Security

You can set up security for your projector to use on a wireless network. Set up one of the following security options to match the settings used on your network:

- WPA2-PSK security
- WPA2-EAP security *
- WPA/WPA2-PSK security *
- WPA/WPA2-EAP security *

* Only available for the Advanced connection mode.



Contact your network administrator for guidance on entering the correct information.

- 1 Save the certificate in a format supported by the projector in the root directory of the USB storage device.
 - ☛ "Supported Client and CA Certificates" [p.123](#)
- 2 Press the [Menu] button on the control panel or remote control.
- 3 Select the **Network** menu and press [Enter].
- 4 Select **Network Configuration** and press [Enter].
- 5 Select the **Wireless LAN** menu and press [Enter].

- 6 Select the **Security** setting and press [Enter].

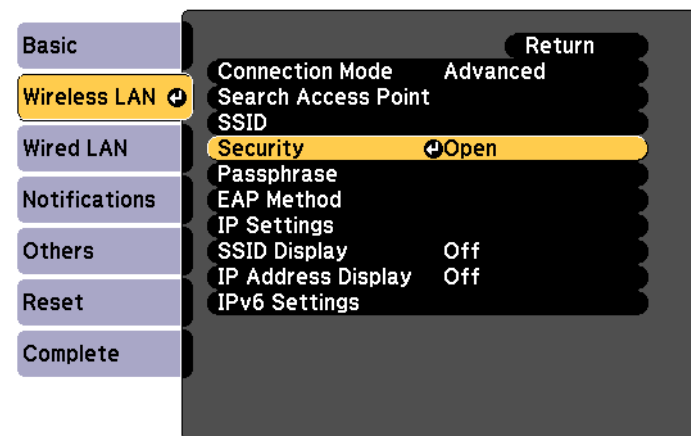

[Esc] :Return [↩]:Select [↵]:Enter

- 7 Select the security settings to match your network settings.
 - WPA2-PSK, WPA/WPA2-PSK:
Select **Setup complete**. Follow the on-screen instructions to save the settings and close the menu.
 - WPA2-EAP, WPA/WPA2-EAP:
Select **EAP Method** and press [Enter].
- 8 Select the protocol for authentication as the **EAP Type** setting.
- 9 To import your certificate, select the certificate type and press [Enter].
 - **Client Certificate** for the **PEAP-TLS** or **EAP-TLS** type
 - **CA certificate** for the **PEAP**, **PEAP-TLS**, **EAP-TLS**, or **EAP-FAST** type



You can also register the digital certificates from your Web browser. However, be sure to register just once or the certificate may not install correctly.

☞ "Setting a certificate using a Web browser" [p.129](#)

- 10** Select **Register** and press [Enter].
- 11** Connect the USB flash drive to the USB-A port on the projector.
- 12** Press [Enter] to display the certificate list.
- 13** Select the certificate to import using the displayed list.
A message is displayed prompting you to enter the password for the certificate.
- 14** Enter a password and press [Enter].
The certificate is imported and a completion message appears.
- 15** Select your EAP settings as necessary.

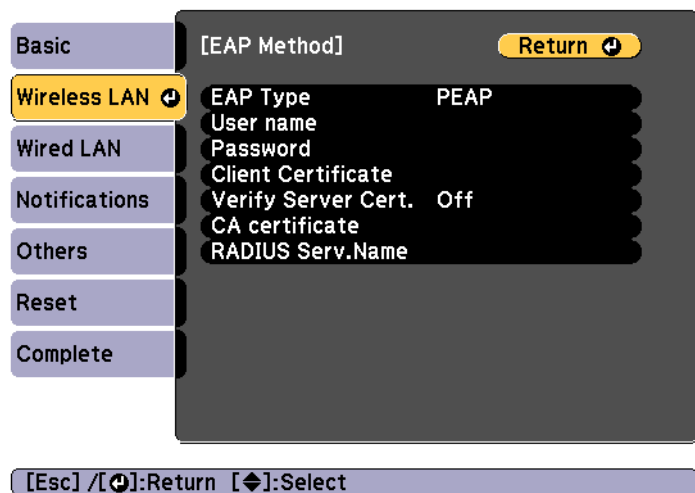

- **User name:** Enter the user name. You can enter up to 64 single-byte alphanumeric characters. When entering more than 32 characters, use your Web browser to enter the text. When importing a client certificate, the name the certificate was issued to is automatically set.
- **Password:** Enter the password used for authentication in **PEAP**, **EAP-FAST**, and **LEAP**. You can enter up to 64 single-byte alphanumeric characters. When entering more than 32 characters, use your Web browser to enter the text.
- **Verify Server Cert.:** Lets you select whether or not to verify the server certificate when a CA certificate has been set.
- **RADIUS Serv.Name:** Lets you enter the server name to be verified.

- 16** If you have finished making settings, select **Setup complete**. Follow the on-screen instructions to save the settings and close the menu.

Supported Client and CA Certificates

You can register these types of digital certificates.

Client Certificate (PEAP-TLS/EAP-TLS)

Item	Explanation
Format	PKCS#12
Extension	PFX, P12
Encryption	RSA
Hashes	MD5/SHA-1/SHA-256/SHA-384/SHA-512
Key length	512/1024/2048/4096 bit
Password *	You need to setup a password. Up to 32 single-byte alphanumeric characters

CA Certificate (PEAP/PEAP-TLS/EAP-TLS/EAP-FAST)

Item	Explanation
Format	X509v3
Extension	DER/CER/PEM
Encryption	RSA
Hashes	MD5/SHA-1/SHA-256/SHA-384/SHA-512
Key length	512/1024/2048/4096 bit
Encoding	BASE64/Binary

* You can set a password using up to 64 alphanumeric characters. When entering more than 32 characters, use your Web browser to enter the text.

 "Changing Settings Using a Web Browser (Epson Web Control)"
[p.214](#)

Using a QR Code to Connect a Mobile Device

After making the wireless network settings for your projector, you can display a QR code on the screen and use it to connect a mobile device using the Epson iProjection (iOS/Android) app.



- Make sure you have installed the latest version of Epson iProjection on your device (Epson iProjection V1.3.0 or later supports this feature).
- You can download Epson iProjection for free from the App Store or Google Play. Any fees incurred when communicating with the App Store or Google Play are the responsibility of the customer.
- When using Epson iProjection in Quick, we recommend making security settings.

1 Press the [LAN] button on the remote control or select **Display the QR Code** in the projector's **Network** menu.

The QR code is displayed on the projected surface.



- If you do not see the QR code, set the **Display LAN Info.** setting to **Text & QR Code** in the projector's Network menu.
 **Network - Network Configuration - Display LAN Info.** [p.148](#)
- To hide the QR code, press the [Esc] button.
- When the QR code is hidden, press the [Enter] button to display the code.

2 Start Epson iProjection on your mobile device.

3 Read the projected QR code using Epson iProjection to connect it to the projector.



To correctly read the QR code, make sure you face the screen squarely and closely enough so that the projected code fits into the guide of the mobile device's QR code reader. If you are too far from the screen, the code may not be read.

When a connection is established, select **Contents** menu from , and then select the file you want to project.

Using a USB Key to Connect a Windows Computer

You can set up your USB flash drive as a USB key to quickly connect the projector to a wireless LAN supported Windows computer. The USB key allows you to automatically select a computer's wireless LAN settings and project images wirelessly.

- 1** Set up the USB key using Epson iProjection (Windows). See the "Epson iProjection Operation Guide (Windows/Mac)" for instructions.
- 2** Turn on the projector.
- 3** Press the [LAN] button on the remote control. The LAN standby screen is displayed. Verify that an SSID and IP address are displayed.
- 4** Connect the USB key to the USB-A port on the projector.
- 5** Remove the USB key.
- 6** Connect the USB key to a USB port on your computer.
- 7** Follow the on-screen instructions to install the necessary application.



- If the Windows Firewall message is displayed, click **Yes** to disable the firewall.
- You need administrator authority to install the software.
- If it is not installed automatically, double-click **MPPLaunch.exe** in the USB key.

After a few minutes, your computer image is displayed by the projector. If it does not appear, press the [LAN] button on your projector's remote control or restart your computer.

- 8** Run your presentation.
- 9** When you have finished projecting wirelessly, select the **Safely Remove Hardware** option in the Windows taskbar, and then remove the USB key from your computer.



You may need to restart your computer to reactivate your wireless LAN connection.

By using the projector's LCD display while it is in standby mode, you can manually set a fixed IP address without projecting any information from the projector.



Make the following settings to set a fixed IP address when the projector is in standby mode.

- Set **A/V Output** to **Always On**.
☛ **Extended - A/V Settings - A/V Output p.143**
- Set **Standby Mode** to **Communication On**.
☛ **Extended - Standby Mode p.143**

- 1** Connect the projector with a wired LAN, and then turn on the main power switch.
- 2** Hold down the [HDBaseT/LAN] button on the control panel for at least three seconds.
The static IP address setting menu is displayed on the LCD display.

Start
IP Setting



Press the [Esc] button to cancel the settings.

- 3** On the control panel or the remote control, press the buttons in the order [↵], [▼] to select **OFF**, then press the [↵] button.

DHCP
 ON
 OFF

- 4** On the control panel or the remote control, use the [▲][▼] buttons to change the values, use the [◀][▶] buttons to move the input position and set the IP address, and then press the [↵] button.

IP Address
192.168.100.100



You can also make settings by pressing the numeric buttons on the remote control.

- 5** Continue to set the subnet mask and gateway address if necessary, and then press the [↵] button on the confirmation screen.

Finish
IP Setting

- 6** Press the [↵] button to return to the status information screen.

You can use the HTTPS protocol to increase security between the projector and a Web browser communicating with it. To do this, you create a server certificate, install it on the projector, and turn on the **Secure HTTP** setting in the projector menus to verify the reliability of the Web browser.

☛ **Network - Network Configuration - Others - Secure HTTP** [p.148](#)

Even if you do not install a server certificate, the projector automatically creates a self-signed certificate and allows communication. However, because the self-signed certificate cannot verify reliability from a Web browser, you see a warning about the server's reliability when you access the projector from a Web browser. This warning does not prevent communication.

Importing a Web Server Certificate Using the Menus

You can create your Web server certificate, and import it using the projector menus and a USB flash drive.



You can also register the digital certificates from your Web browser. However, be sure to register just once or the certificate may not install correctly.

☛ "Setting a certificate using a Web browser" [p.129](#)

- 1** Save the certificate in a format supported by the projector in the root directory of the USB storage device.
☛ "Supported Web Server Certificates" [p.129](#)
- 2** Press the [Menu] button on the control panel or remote control.
- 3** Select the **Network** menu and press [Enter].
- 4** Select **Network Configuration** and press [Enter].

- 5** Select the **Others** menu and press [Enter].

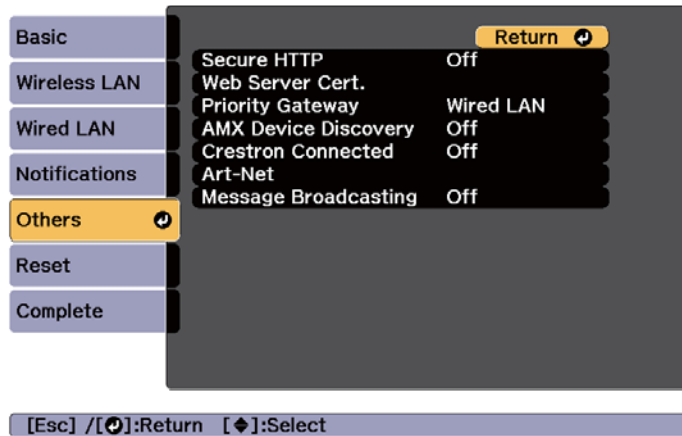

- 6** Select **On** as the **Secure HTTP** setting.
- 7** Select **Web Server Cert.** and press [Enter].
- 8** Select **Register** and press [Enter].
- 9** Connect the USB flash drive to the USB-A port on the projector.
- 10** Press [Enter] to display the certificate list.
- 11** Select the certificate to import using the displayed list.
A message is displayed prompting you to enter the password for the certificate.
- 12** Enter a password and press [Enter].
The certificate is imported and a completion message appears.

Supported Web Server Certificates

You can register these types of digital certificates.

Web Server Certificate (Secure HTTP)

Item	Explanation
Format	PKCS#12
Extension	PFX, P12
Encryption	RSA
Hashes	MD5/SHA-1/SHA-256/SHA-384/SHA-512
Key length	512/1024/2048/4096 bit
Common Name	Network Host Name
Organization	Optional
Password *	You need to setup a password. Up to 32 single-byte alphanumeric characters

* You can set a password using up to 64 alphanumeric characters. When entering more than 32 characters, use your Web browser to enter the text.

☛ "Setting a certificate using a Web browser" [p.129](#)

Setting a certificate using a Web browser

You can use an electronic certificate as the projector's security settings.



You can install the electronic certificate from the projector's Network menu. However, be sure to register just once or the certificate may not install correctly.

☛ "Setting Up Wireless Network Security" [p.122](#)

- 1** Prepare a certificate that is supported by the projector.

- 2 Make sure the projector is turned on.
- 3 Launch the Web browser on the computer or mobile device connected to the network.
- 4 Enter the IP address of the projector in the address input box of the browser to connect to the Epson Web Control screen.

The Epson Web Control screen is displayed.

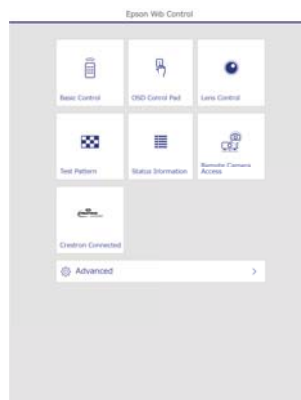

- 5 Select **Advanced**.



You need to login to display the Advanced screen. When the login screen is displayed, enter your user name and password. (User name is **EPSONWEB**; default password is **admin**.)

- 6 Select **Certificate** from **Network**.
- 7 Click the **Choose File** button, select the certificate file.
- 8 Enter the password in the **Password** box, and then click **Send**.
- 9 When the settings are complete, click **Apply**.



Configuration Menu

This chapter explains how to use the Configuration menu and its functions.

This section explains how to use the Configuration menu.

Although steps are explained using the remote control as an example, you can perform the same operations from the control panel. Check the guide under the menu for the available buttons and their operations.



If you operate the menus while projecting, the last menu screen you used is displayed. However, after using the following menus, you are returned to the opening screen.

- Test Pattern
- Focus, Distortion, Zoom, Lens Shift
- Gamma
- Panel Alignment
- User's Logo
- Projector Grouping, Tiling
- Date / Time Settings
- Network Settings
- Reset All (Factory Default)
- Black Level

Hold down the [Esc] button to display the top level menu screen. When you turn off the projector, menu operations return to the opening screen.

1 Display the Configuration menu screen.

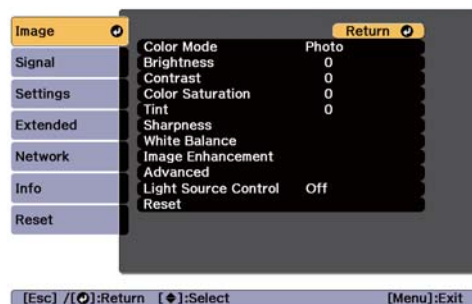
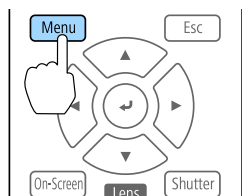

2 Select a top menu item.

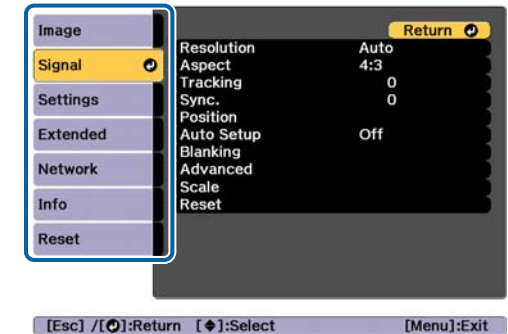
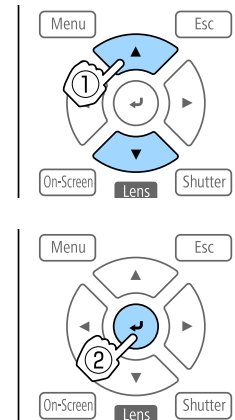

3 Select a submenu item.

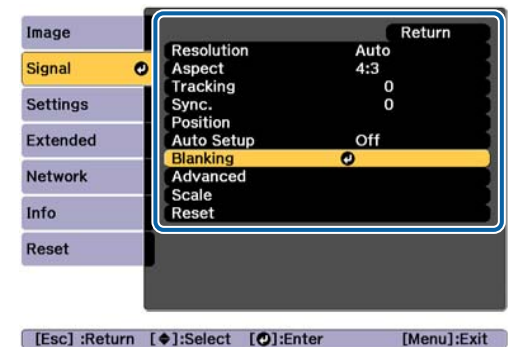
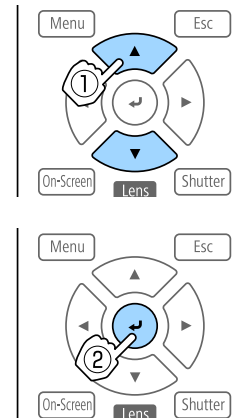

4 Change settings.

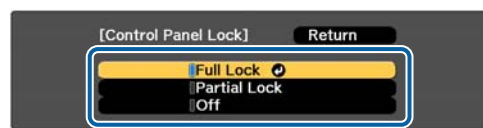
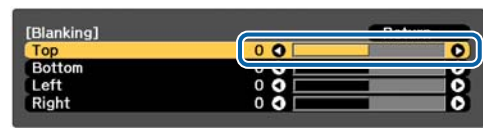
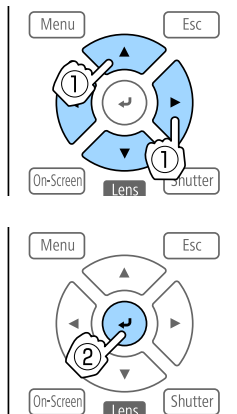

When "[Default]: Reset" is displayed on the guide under the menu, pressing the [Default] button on the remote control returns the settings being adjusted to their default values.

5 Press the [Menu] button to finish making settings.

Configuration Menu Table

Settable items vary depending on the model being used and the image signal and source being projected.

Top Menu Name	Submenu Name	Items or Setting Values
Image menu ☛ p.137	Color Mode	Dynamic, Presentation, Natural, Cinema, BT.709, DICOM SIM, Multi-Projection
	Brightness	0 to 100
	Contrast	0 to 100
	Color Saturation	0 to 100
	Tint	0 to 100
	Sharpness	Standard, Thin Line Enhancement, Thick Line Enhancement
	White Balance	Color Temp., G-M Correction, Offset R, Offset G, Offset B, Gain R, Gain G, Gain B
	Image Enhancement	Image Preset Mode, Deinterlacing, Noise Reduction, Detail Enhancement, Reset
	Advanced	Gamma, RGBCMY
	Light Source Control	Light Source Control, Dynamic Contrast, Lights-Out Control
Signal menu ☛ p.138	Resolution	Auto, Wide, Normal, and Manual
	Aspect	Auto, Normal, 4:3, 16:9, Full, H-Zoom, V-Zoom, Native
	Tracking	-
	Sync.	0 to 31
	Position	-128 to 127
	Auto Setup	On, Off

Top Menu Name	Submenu Name	Items or Setting Values
	Overscan	Auto, Off, 4%, and 8%
	Blanking	Top, Bottom, Left, and Right
	Color Space	Auto, BT.709, BT.2020
	Dynamic Range	Dynamic Range, HDR10 Setting, HLG Setting
	Advanced	Video Range, Input Signal, EDID, DDC Buffer
	Scale	Scale, Scale Mode, Scale Vertically, Scale Horizontally, Clip Adjustment, Clip Range
Settings menu ☛ p.141	Geometry Correction	Off, H/V-Keystone, Quick Corner, Curved Surface, Corner Wall, Point Correction, Memory
	Split Screen	-
	Lock Setting	Control Panel Lock, Lens Lock
	Brightness Settings	Light Source Mode, Brightness Level, Constant Brightness, Estimated Remains
	Remote Receiver	Front/Rear, Front, Rear, and Off
	User Button	User Button 1, User Button 2, and User Button 3
	Test Pattern	Standard, Cross-hatching, Cross-hatching R, Cross-hatching G, Cross-hatching B, Color Bars V, Color Bars H, Grayscale, Gray Bars V, Gray Bars H, Checkerboard 1, Checkerboard 2, White, Black, Aspect Frame
	Memory	Memory, Lens Position, Geometry Correction

Top Menu Name	Submenu Name	Items or Setting Values
Extended menu ☛ p.143	Display	Menu Position, Message Position, Messages, Display Background, Startup Screen, Standby Confirmation, Air Filter Notice, Screen, Panel Alignment, Color Uniformity, OSD Rotation
	User's Logo	Start Setting, Reset
	Projection	Front, Front/Ceiling, Rear, and Rear/Ceiling
	Operation	Direct Power On, Sleep Mode, Sleep Mode Timer, High Altitude Mode, Startup Source Search, Shutter Settings, Video Terminal Settings, Advanced, Date & Time, Lens Calibration
	A/V Settings	A/V Output
	Standby Mode	Communication On and Communication Off
	HDBaseT	Control Communications, Extron XTP
	SDI Settings	Slot 1, Slot 2
	DisplayPort Settings	Slot 1, Slot 2
	Color Calibration	Start Auto Adjustment, Undo, Redo, Color Uniformity
	Multi-Projection	Projector ID, Projector Grouping, Tiling, Geometry Correction, Edge Blending, Black Level, Scale, Reset, Screen Matching
	Schedule Settings	-
	Language	27 languages

Top Menu Name	Submenu Name	Items or Setting Values	
Info menu ☛ p.158	Projector Info	Operation Hours, Source, Input Signal, Resolution, Refresh Rate, Sync Info, Color Format, Status, Serial Number, Lens Type, Event ID, HDBaseT Signal Level	
	Light Source Info	Light Source Hours, Estimated Remains	
	Version	Main, Video2, Sub, Sub2, Image Control, Image Control2, HDBaseT, HDBaseT2, Status Monitor, AC Monitor	
	Version (Slot)	Slot1, Slot2	
	Status Information	Status Information, Source, Signal Information, Network Wired, Network Wireless, Maintenance, Version	
	Voltage Warning Info	-	
	Temp Warning Info	-	
	Power On/Off History	-	
	Reset menu ☛ p.159	Reset All Memories	-
		Light Source Calibration	Run Now, Run Periodically, Schedule Settings, Last Run
Reset All Config		-	
Reset All (Factory Default)		Reset All (Factory Default), Password	

Network menu

Top Menu Name	Submenu Name	Items or Setting Values
Basic menu ☛ p.150	Projector Name	-
	PJLink Password	-

Top Menu Name	Submenu Name	Items or Setting Values
	Remote Password	-
	Web Control Password	-
	Moderator Password	-
	Projector Keyword	On, Off
	Display Keyword	On, Off
	Display LAN Info.	Text & QR Code, Text
Wireless LAN menu ☛ p.151	Connection Mode	Quick, Advanced
	Search Access Point	-
	SSID	-
	Security	Open, WPA2-PSK, WPA/WPA2-PSK, WPA2-EAP, WPA/WPA2-EAP
	Passphrase	-
	EAP Method	EAP Type, User name, Password, Client Certificate, Verify Server Cert., CA certificate, RADIUS Serv.Name
	Channel	1ch, 6ch, and 11ch
	IP Settings	DHCP, IP Address, Subnet Mask, Gateway Address
	SSID Display	On, Off
	IP Address Display	On, Off
Wired LAN menu ☛ p.155	IP Settings	DHCP, IP Address, Subnet Mask, Gateway Address

Top Menu Name	Submenu Name	Items or Setting Values	
Notifications menu ☛ p.155	IP Address Display	On, Off	
	IPv6 Settings	IPv6, Auto Configuration, Use Temporary Address	
	Mail Notification	On, Off	
	SMTP Server	-	
	Port Number	-	
	From	-	
	Address 1 Setting, Address 2 Setting, Address 3 Setting	Email Address, No Signal, System Error, Laser Error, High Temp Error, Air Filter Error, Laser Warning, High Temp Warning, Air Filter Warning, Shutter Warning, Air Filter Notice, Constant Bright. End	
	SNMP	On, Off	
	Trap IP Address 1, Trap IP Address 2	-	
	Community Name	-	
	PJLink Notification	On, Off	
	Notified IP Address	-	
	Others menu ☛ p.157	Secure HTTP	On, Off
		Web Server Cert.	-
Priority Gateway		Wired LAN, Wireless LAN	
AMX Device Discovery		On, Off	
Crestron Connected		On, Off	

Top Menu Name	Submenu Name	Items or Setting Values
	Art-Net	Art-Net, Net, Sub-Net, Universe, Start Channel
	Message Broadcasting	On, Off

Image Menu

Settable items vary depending on the image signal and source currently being projected. Setting details are saved for each color mode.

☛ "Changing the Projected Image" [p.62](#)

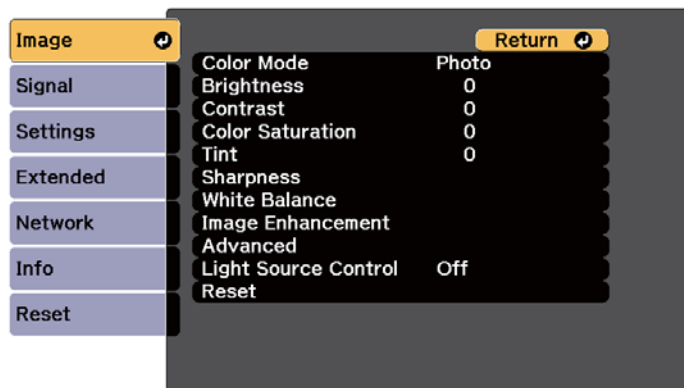



[Esc] / [Return]:Return [Down Arrow]:Select [Menu]:Exit

Submenu	Function
Color Saturation	Adjusts the color saturation for the images.
Tint	You can adjust the image tint.
Sharpness	Standard: You can adjust the image sharpness. Thin Line Enhancement: If this parameter is set to a positive value, details such as hair or fabric patterns will be enhanced. Thick Line Enhancement: If this parameter is set to a positive value, the outline, background, and the other main parts of the objects in the image will be enhanced to show them clearly.
White Balance	Color Temp.: You can adjust the overall tint of the image within 14 levels from 3200K to 10000K. The image is tinted blue when a high value is selected and tinted red when a low value is selected. When Color Mode is set to Dynamic , the set Color Temp. may differ from the actual Color Temp. of the light from the projector. Use this menu as a guide. G-M Correction: The color tone is tinted red when set to a negative value, and tinted green when set to a positive value. Offset R/G/B, Gain R/G/B: You can adjust the offset and gain of each color R (red), G (green), and B (blue) individually.

Submenu	Function
Color Mode	You can select the quality of the image to suit your surroundings. ☛ "Selecting the Projection Quality (Selecting Color Mode)" p.76
Brightness	Adjusts the image brightness.
Contrast	Adjusts the difference between light and shade in the images.

Submenu	Function
Image Enhancement	<p>You can adjust the image resolution.  "Adjusting Image Resolution (Image Enhancement)" p.83</p> <p>Image Preset Mode: You can select the optimal setting according to the projected image from five presets prepared in advance.</p> <p>Deinterlacing*: You can convert interlace signals into progressive signals. (IP conversion)</p> <p>Off is ideal for images with a large amount of movement, Video for general video images, and Film/Auto for movie films, computer graphics, and animation.</p> <p>Noise Reduction: You can smooth out the roughness in progressive images.</p> <p>Detail Enhancement: You can enhance the contrast of details in an image.</p> <p>Reset: You can reset all adjustment values for Image Enhancement to their default values.</p>
Advanced	<p>You can make adjustments by choosing the following items.</p> <p>Gamma: You can adjust the coloring by selecting one of the gamma correction values, or referring to the projected image or a gamma graph.</p> <p>RGBCMY: You can adjust the hue, saturation, and brightness of each color R (red), G (green), B (blue), C (cyan), M (magenta), Y (yellow) individually.</p>

Submenu	Function
Light Source Control	<p>Light Source Control: Select the light source operations according to the image signal.  "Setting the Amount of Light of the Projected Image" p.79</p> <p>Dynamic Contrast: (This can be set only if Light Source Control is set to Dynamic Contrast) Automatically adjusts the amount of light when projecting according to the brightness of the image.</p> <p>Lights-Out Control: (This can be set only if Light Source Control is set to Lights-Out Control) Automatically turns off the light after the set time has elapsed at the specified video level.</p>
Reset	<p>You can reset all adjustment values for the Image menu to their default settings except for Color Mode. See the following to return all menu items to their default settings.  "Reset Menu" p.159</p>

* This can only be set when the input signal is 480i, 576i, or 1080i.

Signal Menu

Settable items vary depending on the image signal and source currently being projected. Setting details are saved for each image signal.

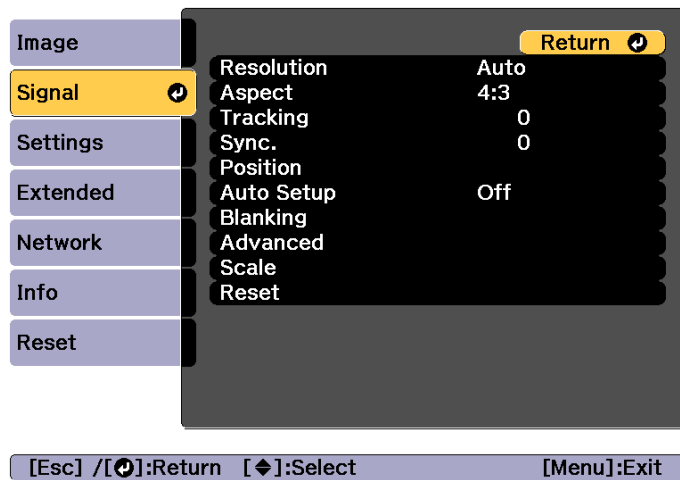

Submenu	Function
Resolution	<p>(Only available when an analog RGB computer signal is being input.)</p> <p>Set to Auto to automatically identify the resolution of the input signal. If images are not projected correctly when set to Auto, for example if some of the image is missing, set to Wide for wide screens, or set to Normal for 4:3 or 5:4 screens depending on the connected computer.</p> <p>Manual allows you to specify the resolution. This is ideal when connected computer is fixed.</p>
Aspect*1	<p>You can set the Aspect Ratio for projected images.</p> <p> "Changing the Aspect Ratio of the Projected Image" p.80</p>
Tracking	<p>(Only available when an analog RGB computer signal is being input.)</p> <p>You can adjust computer images when vertical stripes appear in the images.</p>

Submenu	Function
Sync.	<p>(Only available when an analog RGB computer signal is being input.)</p> <p>You can adjust computer images when flickering, fuzziness, or interference appear in the images.</p>
Position	<p>You can adjust the display position up, down, left, and right when a part of the image is missing so that the whole image is projected.</p>
Auto Setup	<p>(Only available when an analog RGB computer signal is being input.)</p> <p>Set to On to automatically adjust Tracking, Sync., and Position to the optimum state when the input signal changes.</p>
Overscan*1	<p>Changes the output image ratio (the range of the projected image). You can set the cropping range to 4% or 8%. When set to Auto, this is automatically adjusted according to the input signal.</p>
Blanking*1	<p>You can hide images in the set area. Use the [Left][Right] buttons to adjust the area. You can adjust by using a combination of Top, Bottom, Left, and Right. You can hide up to half of the projected image in each direction (except for one pixel).</p>
Color Space*1*2	<p>(Displayed when the current source is HDMI, DVI-D, HDBaseT, SDI, or DisplayPort)</p> <p>Sets the color space conversion method. When Auto is selected, the conversion method is set automatically. Select BT.709 or BT.2020 if necessary.</p>

Submenu	Function
Dynamic Range*1*2	<p>(Displayed when the current source is HDMI, DVI-D, HDBaseT, SDI, or DisplayPort)</p> <p>Make settings for the dynamic range.</p> <p>Dynamic Range: Select range automatically when receiving HDR (High Dynamic Range) signals. This is used when the HDR information is not recorded correctly in the video signal.</p> <p>HDR10 Setting: Set the PQ curve for the HDR PQ (Perceptual Quantizer) signal.</p> <p>HLG Setting: Set the HLG curve for the HDR HLG (Hybrid Log Gamma) signal.</p>

Submenu	Function
Advanced	<p>You can set by choosing the following items.</p> <p>Video Range: Select the video level for the input signal from the HDMI In port, DVI-D In port, HDBaseT port, SDI In port, or DisplayPort In port. If the brightness range is 16 to 235, select Limited (16-235), if it is 0 to 255, select Full (0-255).</p> <p>Input Signal: Select an input signal from the Computer In port. If set to Auto, the input signal is set automatically according to the connected equipment. If colors do not appear correctly when set to Auto, select the appropriate signal according to the connected equipment.</p> <p>EDID: (Displayed when the current source is HDMI, DVI-D, HDBaseT, or DisplayPort) Make settings related to EDID. Even in setups with multiple displays with different resolutions, you can switch the EDID of the current source and unify the EDID across the displays by setting the same EDID as the standard display.</p> <ul style="list-style-type: none"> • Preset EDID: Select the optimal setting from the presets prepared in advance. Change the preset settings for Resolution, Refresh Rate, and Color Depth if necessary. Select Set, and then press the [↵] button. • Resolution: Select from the resolutions displayed. • Refresh Rate: Select from the refresh rates displayed. • Color Depth: Select the maximum color depth limit supported by the projector. When you select 12bit, the projected images support signals up to 12 bits. • Reset: You can reset all adjustment values for EDID to their default values. <p>DDC Buffer: (Displayed when the current source is HDMI or DVI-D) Setting this to On can sometimes improve images that are not displayed correctly from devices connected using an HDMI or DVI extension cable.</p>
Scale*1	<p>When using multiple projectors to project one image, adjust the range of the image displayed by each projector.</p> <p>☞ "Displaying a Scaled Image" p.97</p>





Submenu	Function
Reset	<p>You can reset all adjustment values on the Signal menu to their default settings, except for Input Signal.</p> <p>See the following to return all menu items to their default settings.</p> <p>☛ "Reset Menu" p.159</p>

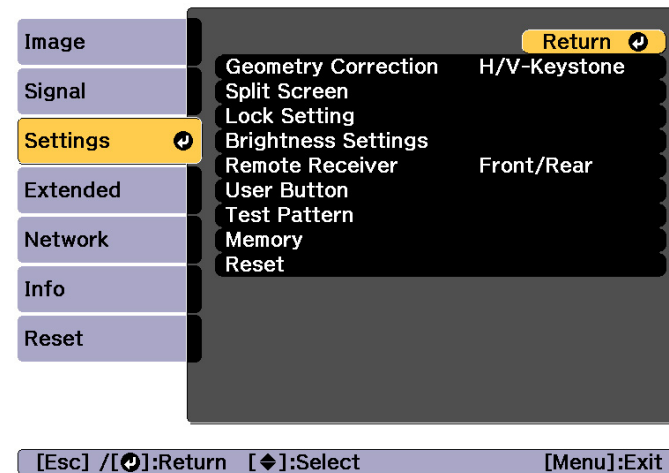

*1 This cannot be set when **Link Type** is set to **Dual (3840x2160)** or **Dual (1920x2160 Split Screen)** in **DisplayPort Settings**.

*2 This cannot be set when **Color Mode** is set to **BT.709**.

Settings Menu



Submenu	Function
Geometry Correction	<p>You can correct distortion.</p> <p> "Correcting Distortion in the Projected Image" p.65</p> <ul style="list-style-type: none"> • Off: Temporarily cancels the geometry correction. • H/V-Keystone: Adjust V-Keystone, V-Balance, H-Keystone, and H-Balance to correct vertical and horizontal keystone distortion. • Quick Corner: Select and correct the four corners of the projected image. • Curved Surface: Corrects distortion that occurs when projecting on a curved surface. • Corner Wall: Corrects distortion that occurs when projecting on a surface with right angles. • Point Correction: Divides the projected image into a grid and corrects the distortion by moving the selected point of intersection from side to side and up and down. • Memory: You can save the adjustment value of the geometry correction and load it when needed.  "Memory Function" p.105
Split Screen	<p>You can split the screen into two screens.</p> <p> "Projecting Two Images Simultaneously (Split Screen)" p.100</p>
Lock Setting	<p>Control Panel Lock: You can use this to restrict operation of the projector's control panel.  "Control Panel Lock" p.113</p> <p>Lens Lock: When set to On, buttons related to lens operations on the remote control are disabled.  "Lens Lock" p.114</p>

Submenu	Function
Brightness Settings	<p>Light Source Mode: Set the brightness for the light source.</p> <ul style="list-style-type: none"> • Normal: Select this if you do not want to decrease the brightness. This makes the light source operation time approximately 20,000 hours. • Quiet: Select this if you are concerned about the noise made by the fan. This sets the brightness at 70%. This makes the light source operation time approximately 20,000 hours. • Extended: Select this to extend the life expectancy of the light source. This sets the brightness at 70%. This makes the light source operation time approximately 43,000 hours. • Custom: Select this to set the brightness level within a range of 30 to 100%. <p>Brightness Level: (Only available when Light Source Mode is set to Custom) Sets the brightness for the light source.</p> <p>Constant Brightness: (Only available when Light Source Mode is set to Custom) When set to On, the brightness of the light source set in Brightness Level is maintained as it is. When Constant Brightness is set to On, you cannot change the settings for Light Source Mode and Brightness Level.</p> <p> "Setting the Brightness" p.77</p> <p>Estimated Remains: When Constant Brightness is set to On, this indicates the amount of time for which constant brightness can be maintained.  "Guide to Estimated Remains" p.78</p>
Remote Receiver	<p>You can limit the reception of the operation signal from the remote control.</p> <p>When set to Off, you cannot perform any operations from the remote control. If you want to make operations from the remote control, hold down the [Menu] button on the remote control for at least 15 seconds to reset the setting to its default value.</p>
User Button	<p>Select the items in the Configuration menu that you want to assign to the [User1], [User2], and [User3] buttons on the remote control. The following items can be assigned.</p> <p>Light Source Mode, Multi-Projection, Resolution, Display the QR Code, Image Enhancement, Screen Matching, Color Calibration, Help, Split Screen</p>

Submenu	Function
Test Pattern	You can display a test pattern to adjust the projection without connecting other equipment when you set up the projector. ☛ "Displaying the Test Pattern" p.37
Memory	Perform operations and make settings for the memory function. ☛ "Memory Function" p.105
Reset	You can reset all adjustment values on the Settings menu to their default settings, except for User Button . See the following to return all menu items to their default settings. ☛ "Reset Menu" p.159

Extended Menu

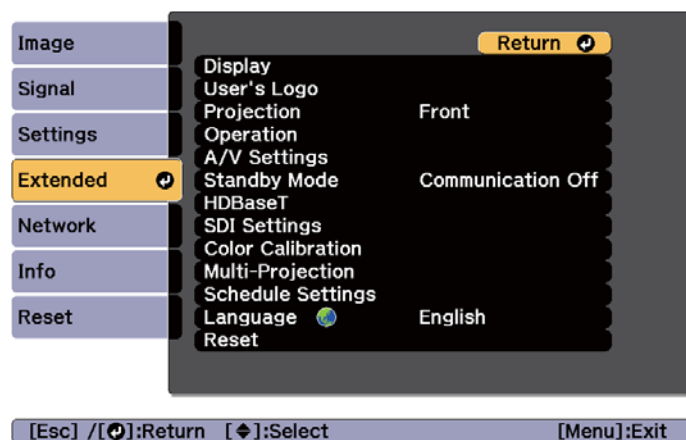



Submenu	Function
Display	You can make settings related to the projector's display. Menu Position: Select the position to display the menu on the projected screen. Message Position: Select the position to display the message on the projected screen. Messages: When set to Off , the following items will not be displayed. Item names when the Source, Color Mode, or Aspect is changed, messages when no signal is being input, and warnings such as High Temp Warning. Display Background*: You can set the screen background to Black , Blue , or Logo when no image signal is available. Startup Screen*: Set to On to display the User's Logo when you start projecting. Standby Confirmation: If it is set to Off , you can turn off the power simply by pressing the [Power] button once. Air Filter Notice: You can set whether or not (On/Off) to enable Air Filter Notice. When this is set to On and a clog in the air filter is detected, the message is displayed on the screen. Screen: (This is unavailable when projecting images from a computer over a network.) Set the aspect ratio and position of the projected screen according to the screen being used. ☛ "Screen Settings" p.36 Panel Alignment: Corrects color misalignments (red and blue) in the screen. ☛ "Panel Alignment" p.44 Color Uniformity: Adjusts the color tone balance for the whole screen. ☛ "Color Uniformity" p.211 OSD Rotation: Rotates the menu direction by 90 degrees.
User's Logo *	You can change the user's logo that is displayed as a background during Display Background, Shutter, and so on. ☛ "Saving a User's Logo" p.103



Submenu	Function
Projection	<p>Select from one of the following projection methods depending on how the projector is installed.</p> <p>Front, Front/Ceiling, Rear, Rear/Ceiling</p> <p>You can change the setting as follows by pressing down the [Shutter] button for about five seconds.</p> <p>Front ↔ Front/Ceiling</p> <p>Rear ↔ Rear/Ceiling</p>

Submenu	Function
Operation	<p>Direct Power On: Set to On to turn on the projector simply by supplying power.</p> <p>When the power cord is plugged in and the main power switch is turned on, note that the projector turns on automatically in cases such as a power outage being restored.</p> <p>Sleep Mode: When set to On, this automatically stops projection when no image signal is being input and no operations are carried out.</p> <p>Sleep Mode Timer: When Sleep Mode is set to On, you can set the time before the projector automatically turns off within a range of 1 to 30 minutes.</p> <p>High Altitude Mode: Set this to On if you are using the projector above an altitude of 1,500 meters.</p> <p>Startup Source Search: Set to On to automatically detect an image signal from another source and project the image when there is no image signal from the current source.</p> <p>Shutter Settings: Make settings related to the shutter.</p> <p> "Hiding the Image Temporarily (Shutter)" p.102</p> <ul style="list-style-type: none"> • Fade-in: Specify the number of seconds for fade-in when displaying an image. • Fade-out: Specify the number of seconds for fade-out when hiding an image. • Shutter Timer: When it is set to On, if no operations are performed for about 2 hours after shutter is activated, the projector turns off automatically. • Shutter Release: When it is set to Shutter, the following operations can be performed while the shutter function is still activated. <ul style="list-style-type: none"> - Change the source with the change input buttons on the remote control. - Use Epson Projector Professional Tool or Epson Projector Management to control the projector from your computer using communication commands.

Submenu	Function
	<p>The shutter function is only released by pressing the [Shutter] button (or by sending a command to release the shutter function).</p> <p>When set to Any Button, the shutter function is released when any operation is performed on the projector.</p> <ul style="list-style-type: none"> • Startup: Set the shutter status when the projector is turned on. • Standby: Set the shutter status when the projector is in standby mode. When Last Used is selected, the current shutter status is maintained when the projector is turned off. <p>Video Terminal Settings: Enable/disable each input port.</p> <p>Advanced: The following items can be set.</p> <ul style="list-style-type: none"> • Beep: When this is set to On, the confirmation buzzer beeps to notify you that the power turns on or off, or cooling down is finished. • Indicators: When set to Off, the projector's indicators are turned off, except for abnormality or warning. • Log Save Destination: Set where you want to save the operation logs for the projector. Select USB and Internal Memory to save the logs to the USB flash drive connected to the projector's USB-A port. Logs are saved as text files (.log) on the USB flash drive. The following logs are saved. <ul style="list-style-type: none"> - Error information - Laser information - Temperature logs - Operation logs • Batch Setup Range: Select All to copy all of the menu settings using the batch setting function. Select Limited if you do not want to copy the following settings. <ul style="list-style-type: none"> • EDID

Submenu	Function
	<ul style="list-style-type: none"> • All items except for the Notifications menu and the Others menu from the Network menu • AC Voltage Monitoring: When this is set to On, and the projector is turned off by any method (including direct shutdown) except for pressing the power button, an AC Voltage Warning dialog is displayed the next time the projector is turned on. Set this to Off if you use direct shutdown regularly. <ul style="list-style-type: none"> ☛ "Explanations of the Display Content" p.181 • Lens Type: When using the following lens, select the model number of the lens. ELPLS04, ELPLU02, ELPLR04, ELPLW04, ELPLM06, ELPLM07, ELPLL07 <p>Date & Time: Make system time settings for the projector. ☛ "Setting the Time" p.48</p> <p>Lens Calibration: Acquires the information of the lens installed on the projector.</p>
A/V Settings	<p>A/V Output: Set this to Always On to set a fixed IP address when the projector is in standby status.</p>
Standby Mode	<p>If you set Communication On, you can perform the following operations even if the projector is in standby mode.</p> <ul style="list-style-type: none"> • Monitor and control the projector over a network. • Communication from the HDBaseT port is enabled. (Only when Control Communications is set to On.) • Set the IP address on the LCD display. (Only when A/V Output is set to Always On.) <div style="border: 1px solid black; padding: 5px; margin-top: 10px;">  <p>When monitoring or controlling the projector using wireless LAN, set Connection Mode to Advanced.</p> <ul style="list-style-type: none"> ☛ Network - Wireless LAN - Connection Mode p.151 </div>

Submenu	Function
HDBaseT	<p>Control Communications: (This cannot be set when Extron XTP is set to On.) When set to On, Ethernet communication, serial communication, and the wired remote control through the HDBaseT Transmitter connected to the HDBaseT port are all enabled.</p> <p>Extron XTP: Set to On when you connect the Extron XTP transmitter or switcher to the HDBaseT port. See the following Extron Web site for more details on the XTP system.</p> <p>http://www.extron.com/</p> <div style="border: 1px solid black; padding: 5px; margin-top: 10px;">  <ul style="list-style-type: none"> • When Control Communications or Extron XTP is set to On, Standby Mode is automatically set to Communication On. • When Control Communications or Extron XTP is On, the projector's LAN port, RS-232 port, and Remote port are disabled. • When Extron XTP is set to On, the fan may rotate in standby mode but this is not abnormal. </div>

Submenu	Function
SDI Settings	<p>Set the signal for the SDI In port.</p> <p>Slot1/Slot2: Select when an SDI interface board is installed in a slot.</p> <ul style="list-style-type: none"> • Link Type: Select Single (Auto)/Single (Manual) to configure one screen with one input signal, or Quad (Auto)/Quad (Manual) to configure one screen with four input signals. To select Quad (Auto)/Quad (Manual), you need to enable the SDI1 In to SDI4 In ports in Video Terminal Settings. <p> Extended - Operation - Video Terminal Settings p.143</p> <p>When Single (Auto)/Quad (Auto) is selected, the signal is automatically determined from the input signal information. When you know the type of input signal, you can select Single (Manual)/Quad (Manual) and set the same signal as the input signal used in Manual Settings.</p> <p>For Manual Settings, set the following items, select Set, and then press the [] button. Not all combinations of items in Manual Settings are supported.</p> <ul style="list-style-type: none"> • SDI Type: Select from the SDI types displayed. • Resolution: Select from the resolutions displayed. • Refresh Rate: Select from the refresh rates displayed. • Color Sampling: Select from the color samplings displayed. • Color Depth: Select from the color depths displayed. • Stream Number (SDI1) to Stream Number (SDI4): (When Manual Settings (SDI Quad) is selected) Select the stream number. Select the appropriate stream number according to the input channel of the SDI1 In to SDI4 In ports. If you do not select the correct number, the image will not be displayed correctly. • Reset: You can reset all adjustment values for Manual Settings to their default values.

Submenu	Function
DisplayPort Settings	<p>Slot1/Slot2: Select when a DisplayPort interface board is installed in a slot.</p> <p>Link Type: Select Single to display the image signal being input to either of the DisplayPort1 In/DisplayPort2 In ports. When connecting two cables to the DisplayPort1 In and DisplayPort2 In ports and inputting a signal, select Dual (3840x2160). (On the computer's settings screen, the projector is recognized as a single display.) If the image is not displayed, you may be able to display it by setting Dual (1920x2160 Split Screen). (On the computer's settings screen, the projector is recognized as two displays.)</p>
Color Calibration	<p>Start Auto Adjustment: Automatically adjusts the color tone for the whole screen. ☛ "Color Calibration" p.210</p> <p>Undo: Undoes the auto adjustment.</p> <p>Redo: Redoes the auto adjustment.</p> <p>Color Uniformity: Adjusts the color tone balance for the whole screen. ☛ "Color Uniformity" p.211</p> <p>Reset: You can reset all adjustment values for Color Calibration to their default values.</p>

Submenu	Function
Multi-Projection	<p>Make settings when projecting from multiple projectors. ☛ "Multi-Projection Function" p.86</p> <p>Projector ID: Set the ID from 1 to 30. Off indicates that no ID is set. ☛ "ID Settings" p.46</p> <p>Projector Grouping: When using multiple projectors to project one image, select the projectors being used.</p> <p>Tiling: Set the number of split screens and positions of each projected image. ☛ "Tiling" p.88</p> <p>Geometry Correction: Corrects distortion in the projected image. ☛ "Correcting Distortion in the Projected Image" p.65</p> <p>Edge Blending: Corrects a border between multiple images to create a seamless screen. ☛ "Edge Blending" p.90</p> <p>Black Level: Adjusts the differences in brightness and tone for areas where images overlap and areas where the images do not overlap. ☛ "Black Level" p.92</p> <p>Scale: (This cannot be set when Link Type is set to Dual (3840x2160) or Dual (1920x2160 Split Screen) in DisplayPort Settings.) When using multiple projectors to project one image, adjust the range of the image displayed by each projector. ☛ "Displaying a Scaled Image" p.97</p> <p>Reset: You can reset all adjustment values for the Multi-Projection menu to their default settings.</p> <p>Screen Matching: Adjusts the tint and brightness for each projector. ☛ "Screen Matching" p.94</p>
Schedule Settings	<p>You can set the projector's schedule so that it performs a specific operation at a pre-scheduled time. ☛ "Scheduling Function" p.107</p>

Submenu	Function
Language	You can set the language for messages and menus.
Reset	<p>You can reset all adjustment values for the Extended menu to their default settings. However, the following items are not reset.</p> <p>Screen Type, Screen Position, Panel Alignment, Color Uniformity, Projection, High Altitude Mode, Startup Source Search, Shutter Release, Lens Type, Date & Time, Lens Calibration, A/V Output, Standby Mode, Control Communications, Extron XTP, Projector ID, Color Calibration, Multi-Projection, and Language</p> <p>See the following to return all menu items to their default settings.</p> <p> "Reset Menu" p.159</p>

* When **User's Logo Protection** is set to **On** in **Password Protection**, you cannot change settings related to user's logo. You can make changes after setting **User's Logo Protection** to **Off**.

 "Managing Users (Password Protection)" [p.111](#)

Network Menu

When **Network Protection** is set to **On** in **Password Protection**, a message is displayed and the network settings cannot be changed. Set **Network Protection** to **Off** and then configure the network.

 "Setting Password Protection" [p.111](#)

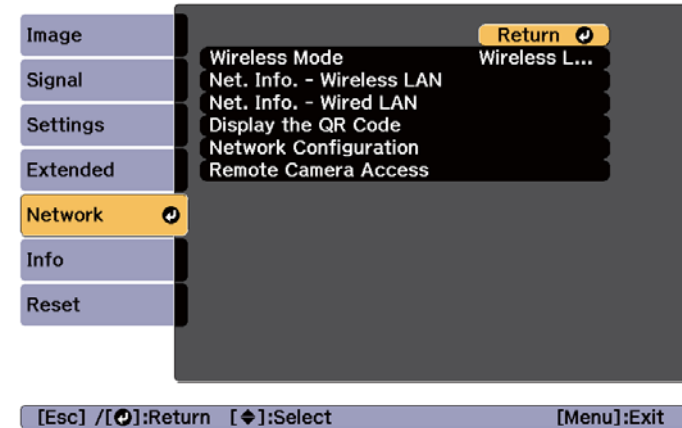

Submenu	Function
Wireless Mode	Set this to Wireless LAN On when connecting the projector and a computer via a wireless LAN. If you do not want to connect via wireless LAN, turn it Off to prevent unauthorized access by others.

Submenu	Function
Net. Info. - Wireless LAN	<p>Displays the following network setting status information.</p> <ul style="list-style-type: none"> • Connection Mode • Wireless LAN system • Antenna Level • Projector Name • SSID • DHCP • IP Address • Subnet Mask • Gateway Address • MAC Address • Region Code <p>When IPv6 is selected, the following information is displayed.</p> <ul style="list-style-type: none"> • IPv6 Address (Manual): IPv6 Address, Prefix Length, Gateway Address • IPv6 Address (Auto): Temporary Address, Link-local Address, Stateless Address, Stateful Address
Net. Info. - Wired LAN	<p>Displays the following network setting status information.</p> <ul style="list-style-type: none"> • Projector Name • DHCP • IP Address • Subnet Mask • Gateway Address • MAC Address • IPv6 Address (Manual): IPv6 Address, Prefix Length, Gateway Address • IPv6 Address (Auto): Temporary Address, Link-local Address, Stateless Address, Stateful Address
Display the QR Code	<p>When connecting iOS or Android devices using Epson iProjection, read the QR code displayed.</p>

Submenu	Function
Network Configuration	<p>The following menus are available for setting Network items. Basic, Wireless LAN, Wired LAN, Notifications, Others, Reset</p>
Remote Camera Access	<p>Set this to On to check the projected image from a remote location. You can also set a password when shooting images using remote camera access from Epson Web Control.</p> <p> "Checking the projected image from a remote location" p.220</p>

Notes on operating the Network menu

Selecting from the top menu and sub menus, and changing selected items is the same as making operations from the Configuration menu.

When done, make sure you go to the **Complete** menu, and select **Yes**, **No**, or **Cancel**. When you select **Yes** or **No**, you are returned to the Configuration menu.



Yes: Saves the settings and exits the Network menu.

No: Does not save the settings and exits the Network menu.

Cancel: Continues displaying the Network menu.

Soft keyboard operations

The Network menu contains items that require input of alphanumerics during setup. In this case, the following software keyboard is displayed. Use [▲][▼][◀][▶] buttons to move the cursor to the desired key, and then press the [↵] button to enter the selected character. Enter figures by holding down the [Num] button on the remote control, and pressing the numeric buttons. After inputting, press **Finish** on the keyboard to confirm your input. Press **Cancel** on the keyboard to cancel your input.



- Each time the **CAPS** key is selected and the [↵] button is pressed, it sets and changes between upper case and lower case letters.
- Each time the **SYM1/2** key is selected and the [↵] button is pressed, it sets and changes the symbol keys for the section enclosed by the frame.

The following types of character can be entered.

Numbers	0123456789
Letters	ABCDEFGHIJKLMNOPQRSTUVWXYZ abcdefghijklmnopqrstuvwxyz
Symbols	!"#\$%&'()*+,-./:;<=>?@[\\]^_`{ }~

Basic menu

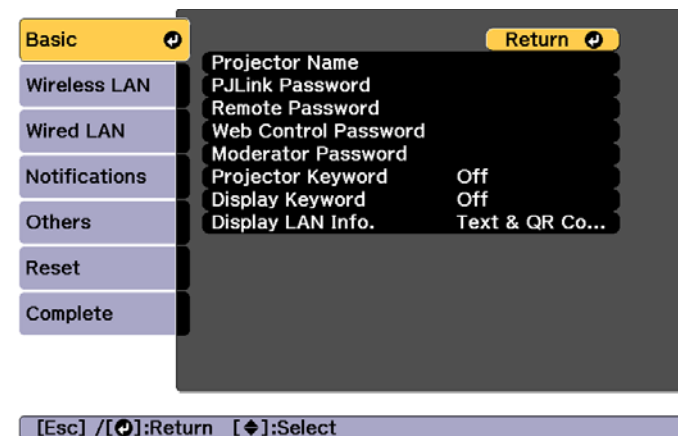

Submenu	Function
Projector Name	Enter the projector name used to identify the projector over a network. When editing, you can enter up to 16 single-byte alphanumeric characters. (" * + , / ; < = > ? [\] ` and spaces cannot be used.)
PJLink Password	Set a password to use when you access the projector using compatible PJLink software. You can enter up to 32 single-byte alphanumeric characters. (Spaces and symbols other than @ cannot be used.) ☛ "About PJLink" p.225
Remote Password	Set a password to use Remote in Epson Web Control. You can enter up to 8 single-byte alphanumeric characters. (* : and spaces cannot be used.) The default user name is "EPSONREMOTE" and the default password is "guest". ☛ "Changing Settings Using a Web Browser (Epson Web Control)" p.214

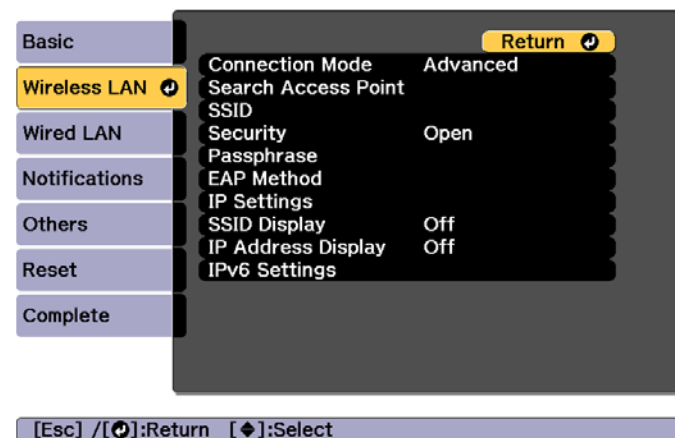

Submenu	Function
Web Control Password	Set a password for authentication to use when making settings and controlling the projector using Web Control in Epson Web Control. You can enter up to eight single-byte alphanumeric characters (* : and spaces cannot be used). The default user name is "EPSONWEB" and the default password is "admin". ☛ "Changing Settings Using a Web Browser (Epson Web Control)" p.214
Moderator Password	Enter the four digit authentication password for using Epson iProjection when connecting to the projector as a moderator. (There is no default password.)
Projector Keyword	Set this to On to enable a security password to prevent other users from accidentally projecting images. When projecting images from a computer or mobile device, you need to enter the keyword displayed on the projection screen in Epson iProjection.
Display Keyword	When this is set to On and when connecting to the projector using Epson iProjection, the projector keyword is displayed on the projection screen. This is only enabled when Projector Keyword is set to On .
Display LAN Info.	Set the display format for the projector's network information. If you display the QR code, you can connect to a network just by reading the QR code in Epson iProjection. Text & QR Code is set by default.

Wireless LAN menu



Submenu	Function
Connection Mode	Set the connection mode to use when connecting the projector and a computer via a wireless LAN. Quick: Lets you directly connect to a smartphone, tablet, or computer via a wireless LAN. Advanced: Lets you connect to a smartphone, tablet, or computer over a wireless LAN access point. The connection is established in infrastructure mode.
Search Access Point	When Connection Mode is set to Advanced , you can search for surrounding access points, and set the SSID to be connected from those access points. Depending on the access point settings, they may not be displayed in the list. ☛ "Search Access Point screen" p.154
SSID	Enter an SSID. When an SSID is provided for the wireless LAN system in which the projector participates, enter the SSID. You can enter up to 32 single-byte alphanumeric characters.

Submenu	Function
Security	<p>Select the security type according to the wireless LAN settings.</p> <p>Open: Security is not set.</p> <p>WPA2-PSK: Communication is performed using WPA2 security. Uses AES method for encryption. When establishing a connection from a computer to the projector, enter the value set in the passphrase.</p> <p>WPA/WPA2-PSK*: Connects in WPA personal mode. Encryption method is selected automatically according to the access point settings. Set a passphrase which is the same for the access point.</p> <p>WPA2-EAP*: Communication is performed using WPA2 security. Uses AES method for encryption.</p> <p>WPA/WPA2-EAP*: Connects in WPA enterprise mode. Encryption method is selected automatically according to the access point settings.</p>
Passphrase	<p>Enter a passphrase used to connect to the network when Security is set to WPA2-PSK or WPA/WPA2-PSK.</p> <p>You can enter at least 8 and up to 63 single-byte alphanumeric characters.</p> <p>You can enter up to 32 characters on the Configuration menu. When entering more than 32 characters, use your Web browser to enter the text.</p> <p> "Changing Settings Using a Web Browser (Epson Web Control)" p.214</p> <p>When Connection Mode is set to Quick, the initial passphrase is set.</p>

Submenu	Function
EAP Method	<p>Set protocols for WPA2-EAP and WPA/WPA2-EAP authentication.</p> <p>EAP Type: Select the certification protocol.</p> <ul style="list-style-type: none"> • PEAP: Authentication protocol widely used in Windows Server. • PEAP-TLS: Authentication protocol used in Windows Server. Select when using a client certificate. • EAP-TLS: Authentication protocol widely used to use a client certificate. • EAP-FAST, LEAP: Select this when these authentication protocols are used. <p>User name: Enter a user name to be used for authentication. You can enter up to 64 single-byte alphanumeric characters.</p> <p>You can enter up to 32 characters on the Configuration menu. When entering more than 32 characters, use your Web browser to enter the text.</p> <p> "Changing Settings Using a Web Browser (Epson Web Control)" p.214</p> <p>If you also need to enter a domain name, add the domain name before the user name separated by a backslash (domain name\user name).</p> <p>Password: Enter the password used for authentication in PEAP, EAP-FAST, and LEAP. You can enter up to 64 single-byte alphanumeric characters. You can enter up to 32 characters on the Configuration menu. When entering more than 32 characters, use your Web browser to enter the text.</p> <p> "Changing Settings Using a Web Browser (Epson Web Control)" p.214</p> <p>When the password is entered and Finish is selected, the value is set and displayed as an asterisk (*).</p> <p>Client Certificate: Imports client certificates for use in PEAP-TLS and EAP-TLS.</p>

Submenu	Function
	<p>Verify Server Cert.: Set to On to perform verification for the certificate of the certification server. To verify a server certificate, you need to set CA certificate.</p> <p>CA certificate: Imports CA certificates for use in PEAP, PEAP-TLS, EAP-TLS, and EAP-FAST.</p> <p>RADIUS Serv.Name: Specify the name of the certification server. You can enter up to 32 single-byte alphanumeric characters.</p>
Channel	You can select the channels used to connect in Quick mode. If interference from other signals occurs, use a different channel.
IP Settings*	<p>Perform network settings.</p> <p>DHCP: Set to On to configure the network using DHCP. If this is set to On, you cannot set any more addresses.</p> <p>IP Address: Enter the IP address assigned to the projector. You can enter a number from 0 to 255 in each field of the address. However, the following IP addresses cannot be used. 0.0.0.0, 127.x.x.x, 224.0.0.0 to 255.255.255.255 (where x is a number from 0 to 255)</p> <p>Subnet Mask: Enter the projector's subnet mask. You can enter a number from 0 to 255 in each field of the address. However, the following subnet masks cannot be used. 0.0.0.0, 255.255.255.255</p> <p>Gateway Address: Enter the IP address for the gateway for the projector. You can enter a number from 0 to 255 in each field of the address. However, the following Gateway Address cannot be used. 0.0.0.0, 127.x.x.x, 224.0.0.0 to 255.255.255.255 (where x is a number from 0 to 255)</p>
SSID Display	To prevent the SSID from being displayed on the LAN Standby screen, set this to Off .
IP Address Display	To prevent the IP address from being displayed on the LAN Standby screen, set this to Off .

Submenu	Function
IPv6 Settings	<p>Perform settings to use the IPv6 protocols.</p> <div style="border: 1px solid black; padding: 10px; margin: 10px 0;">  <ul style="list-style-type: none"> • The following functions support IPv6 protocols. <ul style="list-style-type: none"> - Epson Web Control - PjLink • When setting the IPv6 address manually, make settings in Advanced from Epson Web Control. <ul style="list-style-type: none"> ☛ "Changing Settings Using a Web Browser (Epson Web Control)" p.214 </div> <p>IPv6: Set this to On when using IPv6 protocols. Make sure one link local address is set when using IPv6. This is composed of the interface ID created from fe80:: and the projector's MAC address.</p> <p>Auto Configuration: Set this to On to automatically acquire an IPv6 address from RA (Router Advertisement). The address is composed as shown below.</p> <ul style="list-style-type: none"> • Stateless Address (0 to 6): Created automatically by combining the prefix acquired from the RA (Router Advertisement) and the interface ID created from the projector's MAC address. • Stateful Address (0 to 1): Created automatically from the DHCP server using DHCPv6. <p>Use Temporary Address: Set this to On to temporarily validate the IPv6 address (0 to 1) when Auto Configuration is On.</p>

* This can only be selected when Connection Mode is set to **Advanced**.

Type of security

When using in Advanced connection mode, it is strongly recommended that you set security.

WPA is an encryption standard that improves the security for wireless networks. The projector supports TKIP and AES encryption methods.

WPA also includes user authentication functions. WPA authentication provides two methods: using an authentication server, or authenticating between a computer and an access point without using a server. This projector supports the latter method, without a server.





For setting details, follow the instructions from your network administrator.

Search Access Point screen

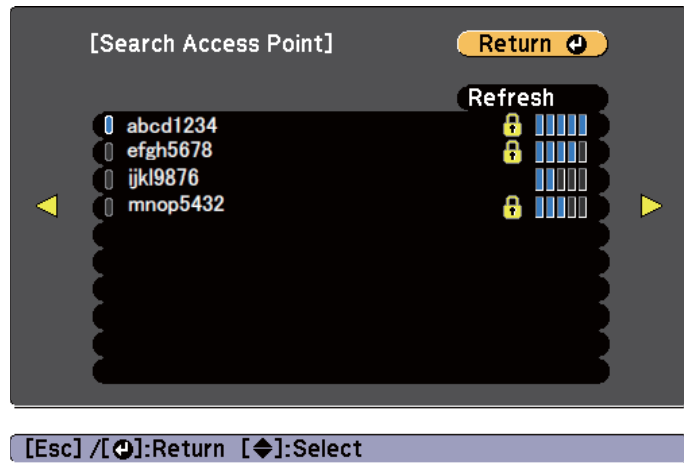
Detected access points are displayed in a list.



Submenu	Function
Refresh	Searches for the access point again.
	Indicates an already set access point.

Submenu	Function
	Indicates the access points where security is set. If you select an access point where security has not been set, the Wireless LAN menu is displayed. If you select an access point where security has been set, the Security menu is displayed. Select a type of security according to the security settings for the access point.

Wired LAN menu

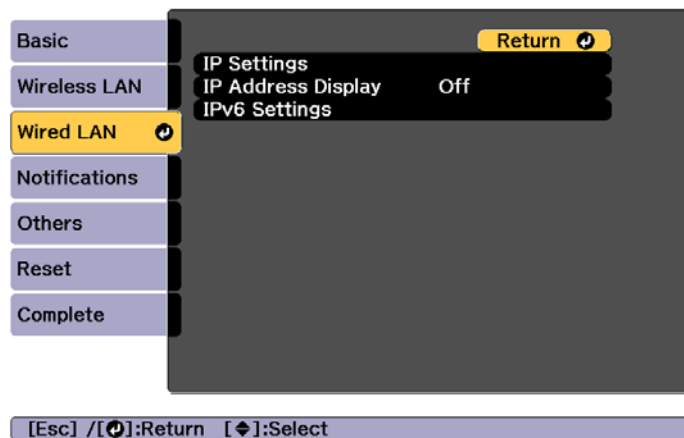

Submenu	Function
IP Settings	<p>You can make settings related to the following addresses.</p> <p>DHCP: Set to On to configure the network using DHCP. If this is set to On, you cannot set any more addresses.</p> <p>IP Address: Enter the IP address assigned to the projector. You can enter a number from 0 to 255 in each field of the address. However, the following IP addresses cannot be used. 0.0.0.0, 127.x.x.x, 224.0.0.0 to 255.255.255.255 (where x is a number from 0 to 255)</p> <p>Subnet Mask: Enter the projector's subnet mask. You can enter a number from 0 to 255 in each field of the address. However, the following subnet masks cannot be used. 0.0.0.0, 255.255.255.255</p> <p>Gateway Address: Enter the IP address for the gateway for the projector. You can enter a number from 0 to 255 in each field of the address. However, the following Gateway Address cannot be used. 0.0.0.0, 127.x.x.x, 224.0.0.0 to 255.255.255.255 (where x is a number from 0 to 255)</p>

Submenu	Function
IP Address Display	To prevent the IP address from being displayed on the LAN Standby screen, set this to Off .
IPv6 Settings	<p>Perform settings to use the IPv6 protocols.</p> <div style="border: 1px solid black; padding: 10px; margin: 10px 0;">  <ul style="list-style-type: none"> The following functions support IPv6 protocols. <ul style="list-style-type: none"> Epson Web Control PJLink When setting the IPv6 address manually, make settings in Advanced from Epson Web Control. <ul style="list-style-type: none"> "Changing Settings Using a Web Browser (Epson Web Control)" p.214 </div> <p>IPv6: Set this to On when using IPv6 protocols. Make sure one link local address is set when using IPv6. This is composed of the interface ID created from fe80:: and the projector's MAC address.</p> <p>Auto Configuration: Set this to On to automatically acquire an IPv6 address from RA (Router Advertisement). The address is composed as shown below.</p> <ul style="list-style-type: none"> Stateless Address (0 to 6): Created automatically by combining the prefix acquired from the RA (Router Advertisement) and the interface ID created from the projector's MAC address. Stateful Address (0 to 1): Created automatically from the DHCP server using DHCPv6. <p>Use Temporary Address: Set this to On to temporarily validate the IPv6 address (0 to 1) when Auto Configuration is On.</p>

Notifications menu

When this is set, you receive an email notification if a problem or warning occurs in the projector.

☛ "Reading error notification mail" p.222

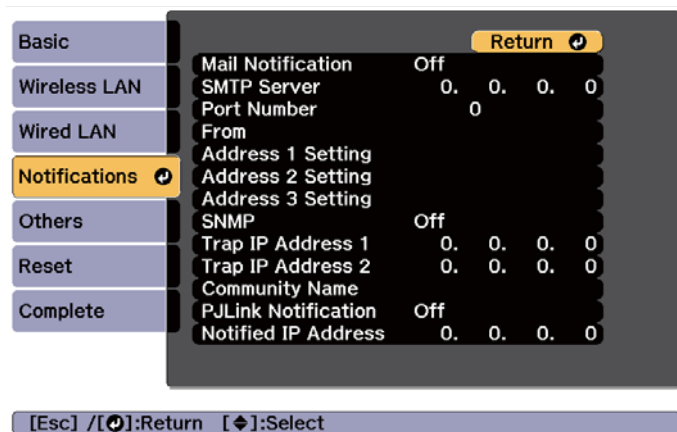



Submenu	Function
Mail Notification	Set to On to send an email to the preset addresses when a problem or warning occurs with a projector.
SMTP Server	You can input the IP Address for the SMTP server for the projector. You can enter a number from 0 to 255 in each field of the address. However, the following IP addresses cannot be used. 127.x.x.x, 224.0.0.0 to 255.255.255.255 (where x is a number from 0 to 255)
Port Number	You can input the port number for the SMTP server. The default value is 25. You can input numbers between 1 to 65535.
From	Enter the email address of the sender. You can enter up to 64 single-byte alphanumeric characters. You can enter up to 32 characters on the Configuration menu. When entering more than 32 characters, use your Web browser to enter the text. (" () , ; < > [\] and spaces cannot be used.) ☛ "Changing Settings Using a Web Browser (Epson Web Control)" p.214

Submenu	Function
Address 1 Setting/ Address 2 Setting/ Address 3 Setting	Set the destination email addresses for the notification email, and the notification content. You can register up to three destinations. You can enter up to 64 single-byte alphanumeric characters. You can enter up to 32 characters on the Configuration menu. When entering more than 32 characters, use your Web browser to enter the text. (" () , ; < > [\] and spaces cannot be used.) ☛ "Changing Settings Using a Web Browser (Epson Web Control)" p.214
SNMP	Set to On to monitor the projector using SNMP. To monitor the projector, you need to install the SNMP manager program on your computer. SNMP should be managed by a network administrator. The default value is Off .
Trap IP Address 1/Trap IP Address 2	You can register up to two IP addresses for the SNMP trap notification destination. You can enter a number from 0 to 255 in each field of the address. However, the following IP addresses cannot be used. 127.x.x.x, 224.0.0.0 to 255.255.255.255 (where x is a number from 0 to 255)
Community Name	Set the community name of SNMP. You can enter up to 32 single-byte alphanumeric characters. (Spaces and symbols other than @ cannot be used.)
PLink Notification	Set this to On to use the PLink notification function.
Notified IP Address	Enter the IP address to receive the projector's operating status when the PLink notification function is enabled. You can enter a number from 0 to 255 in each field of the address. However, the following IP addresses cannot be used. 127.x.x.x, 224.0.0.0 to 255.255.255.255 (where x is a number from 0 to 255)

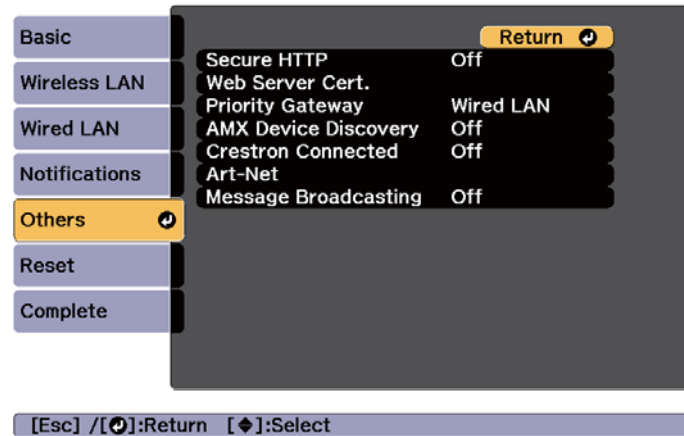
Others menu



Submenu	Function
Secure HTTP	To strengthen security, communication between the projector and computer in Epson Web Control is encrypted. When setting security with Epson Web Control, we recommend setting this to On .
Web Server Cert.	Imports the Web server certificate used in Secure HTTP.
Priority Gateway	For the priority gateway, select either Wired or Wireless .
AMX Device Discovery	When you want to allow the projector to be detected by AMX Device Discovery, set this to On . Set this to Off if you are not connected to an environment controlled by a controller from AMX or AMX Device Discovery.
Crestron Connected	Set this to On only when monitoring or controlling the projector over the network using Crestron Connected®. Otherwise, set this to Off .  "About Crestron Connected®" p.225 Changes in projector settings take effect upon restarting. When this is set to On , the Message Broadcasting feature in Epson Projector Management is not available.

Submenu	Function
Art-Net	Art-Net: Set this to On to control the projector using Art-Net.  "About Art-Net" p.230 Net/Sub-Net/Universe: Sets the projector's Net/Sub-Net/Universe. Start Channel: Sets the start channel that handles Art-Net.  "Channel definitions" p.230
Message Broadcasting	Set this to On to receive information sent by the Message Broadcasting feature in the Epson Projector Management software. Download software and User's Guides from the following Web site. http://www.epson.com

Reset menu

Resets all of the network settings.

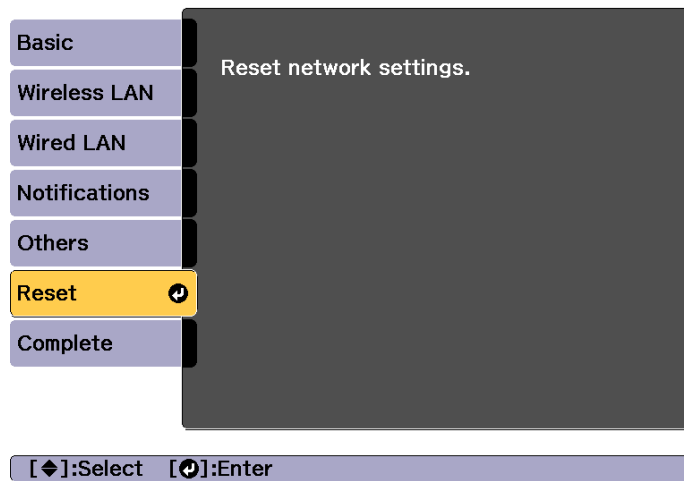

Submenu	Function
Reset network settings.	To reset all of the Network settings, select Yes.

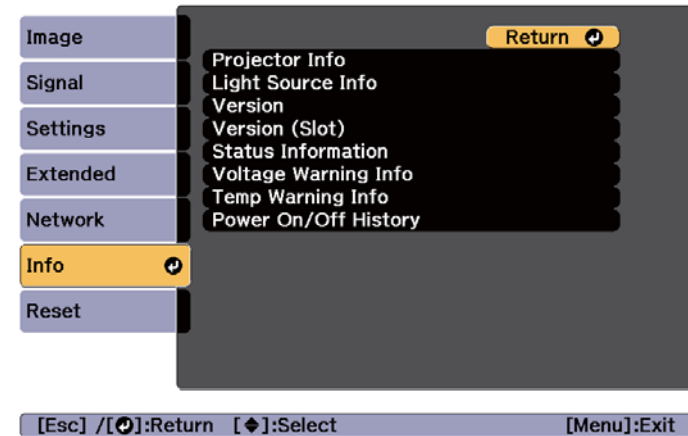

Submenu	Function	
Projector Info	Operation Hours	Displays the operation time after turning on the projector.
	Source	You can display the source name for the connected equipment currently being projected.
	Input Signal	You can display the content of Input Signal set in the Signal menu according to the source.
	Resolution	You can display the resolution.
	Refresh Rate	You can display the Refresh Rate.
	Sync Info	You can display the image signal information. This information may be needed if service is required.
	Color Format	Displays color space and dynamic range information.
	Status	This is information about errors that have occurred on the projector. This information may be needed if service is required.
	Serial Number	Displays the projector's serial number.

Info Menu (Display Only)

Lets you check the status of the image signals being projected and the status of the projector. Items that can be displayed vary depending on the source currently being projected.

Submenu		Function
	Lens Type	Displays the model number of your lens.
	Event ID	When problems occur when the projector and computer are connected through the network, information on the problem is displayed using an Event ID. See the following page for information on interpreting the Event ID. ☛ "About Event ID" p.201
	HDBaseT Signal Level	Displays the level for the image signal being input from the HDBaseT port. When this is displayed in yellow, the strength of the signal level is reduced. We recommend the following signal levels. <ul style="list-style-type: none"> • 1080p: 16 dB or more • 4K: 18dB or more
Light Source Info	Light Source Hours	Displays the operating time for the light source according to the light source mode.
	Estimated Remains	When Constant Brightness is set to On , this displays the amount of time for which the brightness of the light source can be maintained.
Version	Main Video2 Sub Sub2 Image Control Image Control2 HDBaseT HDBaseT2 Status Monitor AC Monitor	Displays the versions of the projector's software and the devices connected to the projector.
Version (Slot)	Slot1 Slot2	Displays the version of the interface board connected to Slot.

Submenu	Function
Status Information	Displays the projector's status. ☛ "Understanding the Status Information" p.178
Voltage Warning Info	Displays a warning regarding the power voltage.
Temp Warning Info	Displays a high temperature warning. When you select Detail when a Warning or Error is displayed, you can check detailed logs for before and after the error was detected.
Power On/Off History	Displays the power on/off logs.

Reset Menu

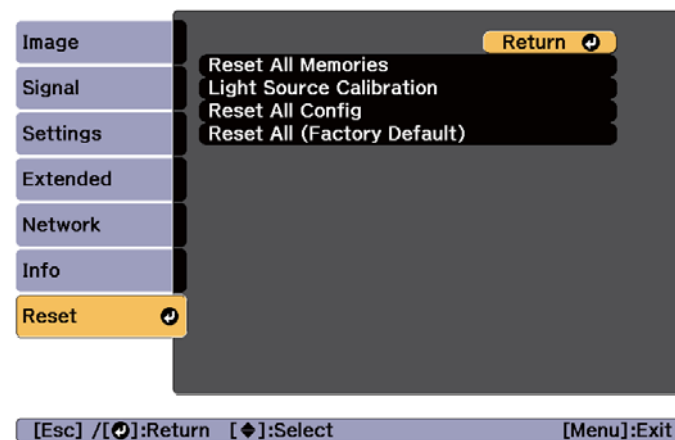

Submenu	Function
Reset All Memories	Resets all names and settings saved in Memory , Lens Position , and Geometry Correction . ☛ "Memory Function" p.105

Submenu	Function
Light Source Calibration	<p>Make settings related to Light Source Calibration. When performing Light Source Calibration, the differences in the White Balance and the Brightness Level for the light source are corrected. We recommend running this function periodically.</p> <ul style="list-style-type: none"> • Run Now: Starts Light Source Calibration. This cannot be started in the following cases. <ul style="list-style-type: none"> • Within 30 minutes of turning off the projector. • If the surrounding temperature gets too high, and the brightness has been automatically dimmed. • Run Periodically: When this is set to On, Light Source Calibration is performed every 100 hours of use. When Off is selected to maintain the projected image that has been adjusted using Multi-Projection, perform corrections using Run Now or set the scheduling function to perform Light Source Calibration periodically. • Schedule Settings: Displays the schedule settings screen. Set Light Source Calibration to run periodically. • Last Run: Displays the last date and time Light Source Calibration was performed.
Reset All Config	<p>You can reset all items in the Configuration menu to their default settings.</p> <p>The following items are not reset to their defaults: Input Signal, Memory, User's Logo, all items for Network menus, Language, Date & Time, Panel Alignment, Color Uniformity, Lens Calibration, Color Calibration, Projector Grouping, Screen Matching, Color Matching, Operation Hours, and Light Source Info.</p>
Reset All (Factory Default)	<p>Resets all of the projector's settings. However, Date & Time, Operation Hours, Light Source Info, Password Protection items and their passwords are not reset. You need to enter a password to perform a reset. The default password is set to "0000". Change this to your own desired password.</p>

Once the Configuration menu content has been set for one projector, you can use it to perform batch setup for multiple projectors (batch setup function). The batch setup function is only for projectors with the same model number.

Use one of the following methods.

- Setup using a USB flash drive.
- Setup by connecting the computer and projector with a USB cable.
- Set through Epson Projector Management.

This manual explains the USB flash drive and the USB cable methods.



- The content for Light Source Info and Status Information from the Info menu is not reflected by the batch setup function.
- Perform batch setup before adjusting the projected image. Adjustment values for the projected image, such as Geometry Correction are reflected by the batch setup function. If batch setup is performed after adjusting the projected image, the adjustments you made may change.
- By using the batch setup function, the registered User's Logo is set for the other projectors. Do not register confidential information and so on as the User's Logo.
- If you do not want to copy the following settings, set **Batch Setup Range** to **Limited**.
 - EDID from the **Signal** menu
 - **Network** menu (except for the **Notifications** menu and the **Others** menu)
-  **Extended - Operation - Advanced - Batch Setup Range** [p.143](#)
- Items for which Password Protection is set are not copied.



Caution

Performing batch setup is the customer's responsibility. If batch setup fails due to a power failure, communication error, and so on, the customer is responsible for any repair costs incurred.

Setup Using a USB Flash Drive

This section explains how to perform batch setup using a USB flash drive.



- Use a FAT format USB flash drive.
- The batch setup function cannot be used by USB flash drives that incorporate security functions. Use a USB flash drive that does not incorporate security functions.
- The batch setup function cannot be used by USB card readers or USB hard disks.

Saving settings to the USB flash drive

- 1 Turn off the main power switch while the power cord is connected to the projector, and check that all of the projector's indicators turn off.
- 2 Connect the USB flash drive to the projector's USB-A port.

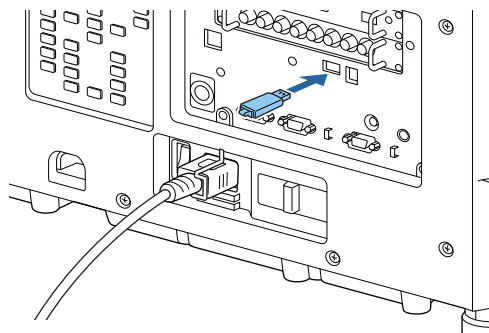

- Connect the USB flash drive directly to the projector. If the USB flash drive is connected to the projector through a USB hub, the settings may not be saved correctly.
- Connect an empty USB flash drive. If the USB flash drive contains data other than the batch setup file, the settings may not be saved correctly.
- If you have saved a batch setup file from another projector to the USB flash drive, delete the file or change the file name. The batch setup function cannot overwrite a batch setup file.
- The file name for the batch setup file is PJCONFDATA.bin. If you need to change the file name, add text after PJCONFDATA. If you change the file name in any other way, the projector may not be able to recognize the file correctly.
- You can only use single-byte characters for the file name.

- 3 While holding down the [Esc] button, turn on the main power switch.

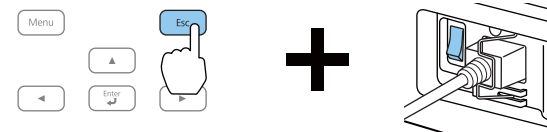

When the projector's indicators turn on as follows, release the [Esc] button.

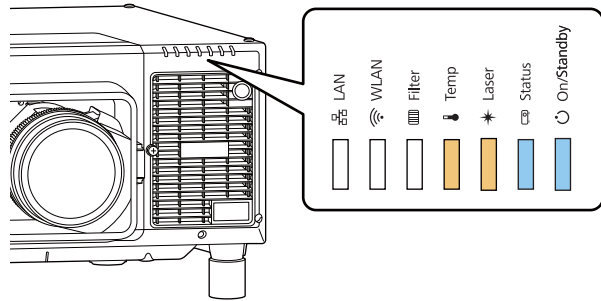

Power	Status	Laser	Temp
Blue - On	Blue - On	Orange - On	Orange - On

When all of the indicators start flashing, the batch setup file is being written.

⚠ Caution

- Do not disconnect the power cord from the projector or turn off the main power switch while the file is being written. If power is not being supplied, the projector may not startup correctly.
- Do not disconnect the USB flash drive from the projector while the file is being written. If the USB flash drive is disconnected, the projector may not start correctly.

When writing completes normally, the projector enters standby status.

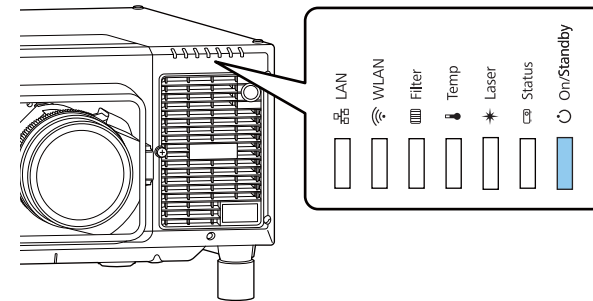

Power
Blue - On

When the projector is in standby status, remove the USB flash drive.

Reflecting saved settings to other projectors

- 1** Turn off the main power switch while the power cord is connected to the projector, and check that all of the projector's indicators turn off.
- 2** Connect the USB flash drive on which the settings are saved to the projector's USB-A port.

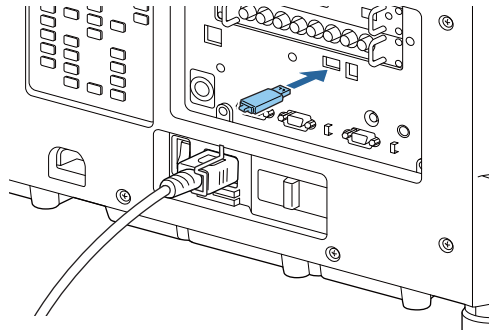

- When the USB flash drive contains 1 to 3 types of batch setup files, the file is reflected to the projector with the same model number. If there are multiple files for a projector with the same model number, the settings may not be reflected correctly.
- When there are four or more types of batch setup files on the USB flash drive, the settings may not be reflected correctly.
- Do not store any data except for the batch setup file on the USB flash drive. If the USB flash drive contains data other than the batch setup file, the settings may not be reflected correctly.

- 3** While holding down the [Menu] button, turn on the main power switch.

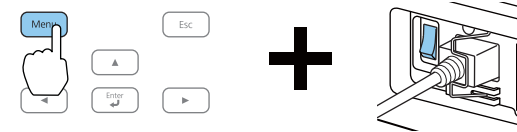

When the projector's indicators turn on as follows, release the [Menu] button.

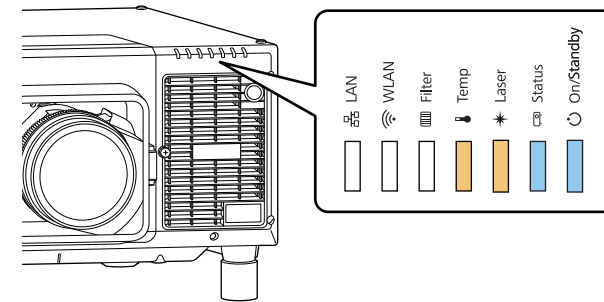

Power	Status	Laser	Temp
Blue - On	Blue - On	Orange - On	Orange - On

The indicators remain on for about 75 seconds.

When all of the indicators start flashing, the settings are being written.

Caution

- Do not disconnect the power cord from the projector or turn off the main power switch while the settings are being written. If power is not being supplied, the projector may not startup correctly.
- Do not disconnect the USB flash drive from the projector while the settings are being written. If the USB flash drive is disconnected, the projector may not start correctly.

- 4** When writing completes normally, the projector enters standby status.

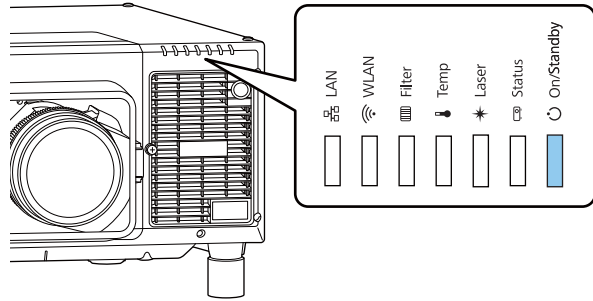

Power
Blue - On

When the projector is in standby status, remove the USB flash drive.

Setup by Connecting the Computer and Projector with a USB Cable



The following operating systems support the batch setup function.

- Windows Vista or later
- OS X 10.7.x or later

Saving settings to a computer

- 1** Turn off the main power switch while the power cord is connected to the projector, and check that all of the projector's indicators turn off.
- 2** Connect the computer's USB port to the projector's Service port with a USB cable.

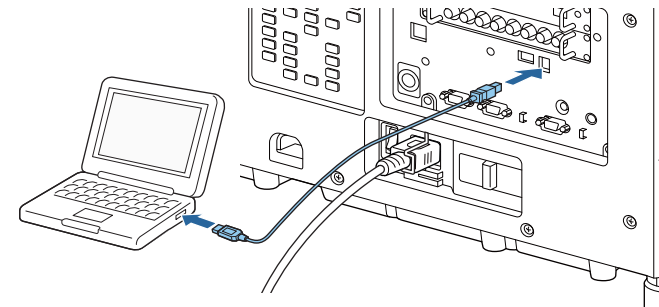

- 3** While holding down the [Esc] button, turn on the main power switch.

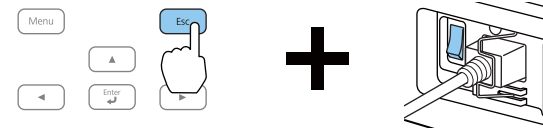

When the projector's indicators turn on as follows, release the [Esc] button.

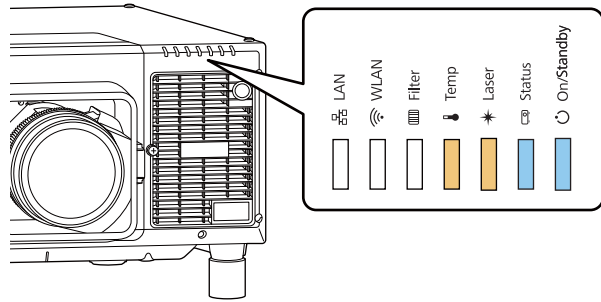

Power	Status	Laser	Temp
Blue - On	Blue - On	Orange - On	Orange - On

The projector is recognized as a removable disk by the computer.

- 4 Open the removable disk, and save the batch setup file (PJCONFDATA.bin) to the computer.



If you need to change the name of the batch setup file, add text after PJCONFDATA. If you change the file name, the projector may not be able to recognize the file correctly.

- 5 Perform "Remove USB device" on your computer, and then disconnect the USB cable.



When using Mac, perform "Remove EPSON_PJ".

The projector enters standby status.

Reflecting saved settings to other projectors

- 1 Turn off the main power switch while the power cord is connected to the projector, and check that all of the projector's indicators turn off.
- 2 Connect the computer's USB port to the projector's Service port with a USB cable.

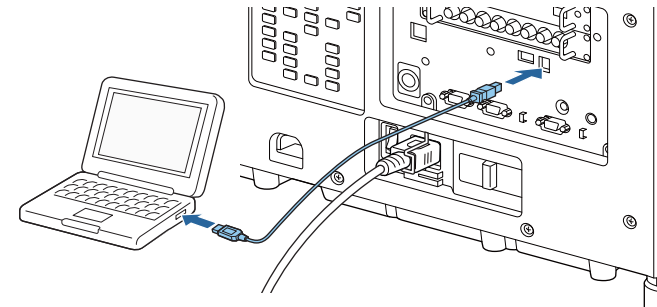

- 3** While holding down the [Menu] button, turn on the main power switch.

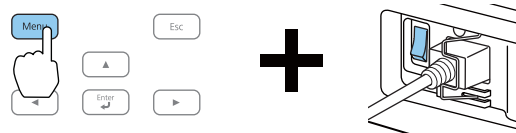

When the projector's indicators turn on as follows, release the [Menu] button.

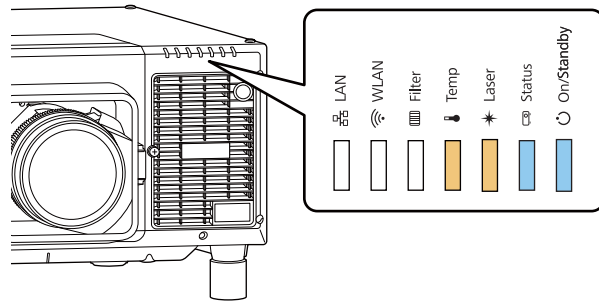

Power	Status	Laser	Temp
Blue - On	Blue - On	Orange - On	Orange - On

The projector is recognized as a removable disk by the computer.

- 4** Copy the batch setup file (PJCONFDATA.bin) that you saved to your computer to the top level folder of the removable disk.



Do not copy any files or folders other than the batch setup file to the removable disk.

- 5** Perform "Remove USB device" on your computer, and then disconnect the USB cable.



When using Mac, perform "Remove EPSON_PJ".

When all of the indicators start flashing, the settings are being written.



Caution

Do not disconnect the power cord from the projector or turn off the main power switch while the settings are being written. If power is not being supplied, the projector may not startup correctly.

When writing completes normally, the projector enters standby status.

When Setup Fails

The Indicators notify you if an error occurs. Check the status of the projector's Indicators and follow the instructions described in the table here.

Status of the Indicators	Remedy
 <p>Temp: Orange - flashing fast Laser: Orange - flashing fast</p>	<p>The batch setup file may be corrupt, or the USB flash drive may not be connected correctly. Disconnect the USB flash drive, unplug and then plug in the projector's power cord, and then try again.</p>
 <p>Temp: Orange - flashing fast Laser: Orange - flashing fast Status: Blue - flashing fast Power: Blue - flashing fast</p>	<p>Writing the settings may have failed and an error may have occurred in the projector's firmware. Stop using the projector, remove the power plug from the electrical outlet, and contact your local dealer or the nearest address provided in the Epson Projector Contact List. Epson Projector Contact List</p>



Troubleshooting

This chapter explains how to identify problems and what to do if a problem is found.

If a problem occurs with the projector, you can display the Help screen to assist you. You can also set the projector to an appropriate state by answering the questions.

 Before displaying the help screen, assign **Help** to a **User Button**.
 🖱️ **Settings - User Button** p.141

1 Press the [User] button to which **Help** was assigned.
 The Help screen is displayed.

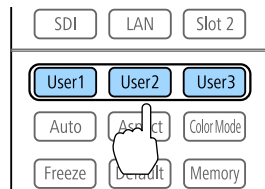

2 Select a menu item.

[Help]

The image is small. ⬇️

The image is distorted.

The color tone is unusual.

There is no audio or it is too low.

[⬅️]:Select [⬇️]:Enter [Menu]:Exit

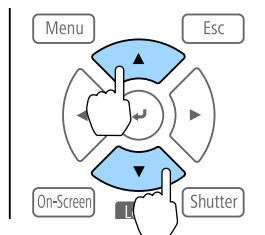

3 Confirm the selection.

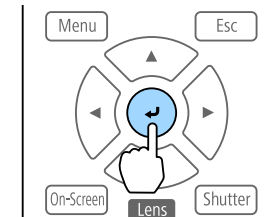

Questions and solutions are displayed as shown on the screen below.
 Press the [Menu] button to exit Help.

The image is small.

❓ Is zoom set to minimum?
 · Press the [Zoom] button to change the size of the image.

❓ Is the projector too close to the screen?
 · Move the projector away from the screen.

[Esc] :Return [Help] :Exit

 See the following if the Help function does not provide a solution to the problem.
 🖱️ "Reading the Indicators" p.171



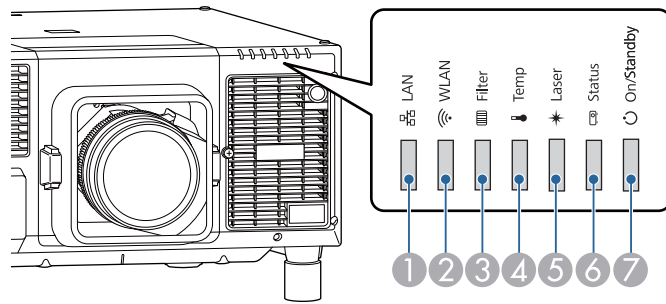

This projector has the following seven indicators to indicate the projector's status.



























- ① LAN indicator
Indicates the status of the wired LAN or the HDBaseT.
- ② WLAN indicator
Indicates the wireless LAN status.
- ③ Filter indicator
Indicates the air filter status. This is normally turned off.
- ④ Temp indicator
Indicates the internal temperature status. This is normally turned off.
- ⑤ Laser indicator
Indicates the light source status.
- ⑥ Status indicator
Indicates the projector's status.
- ⑦ Power indicator
Indicates the projector's status.





















The following indicator status are used during regular operation.











"Status varies" indicates that the indicators turn on, off, or flash depending on the status of the projector.































Indicator					Projector's Status	Explanation
Power	Status	Laser	Temp	Filter		
					Standby condition	Power is being supplied to the projector. In this status, you can start projecting by pressing the [ⓘ] button on the remote control or control panel. (Sometimes, when the power cord is unplugged, the power indicator remains lit for a short period, but this is not a fault.)
Blue - On	Off	Off	Off	Off	Network monitoring status	The projector is being monitored and controlled over a network (when Standby Mode is set to Communication On). If the power cord is disconnected and then reconnected in this status, the power indicator flashes blue.



























Indicator					Projector's Status	Explanation
Power	Status	Laser	Temp	Filter		
 Blue - On	 Blue - Flashing	 Status varies	 Off	 Off	Warm-up status	This is the status immediately after turning on the projector. Warm-up takes approximately 30 seconds after the light source turns on. The [⏻] button is disabled during warm-up.
 Blue - On	 Blue - On	 Status varies	 Off	 Off	Projecting	The projector is projecting.
 Blue - On	 Blue - Flashing	 Off	 Off	 Off	Cool down status	This is the status immediately after turning off the power. In this status, all buttons are disabled.
 Blue - Flashing	 Off	 Off	 Off	 Off	Preparing Network monitoring	Preparing to monitor and control this projector over a network. During network monitoring preparation, all button operations are disabled.
 Blue - On	 Blue - On	 Blue - Flashing	 Off	 Off	Shutter is active	The Shutter function is activated.

When an error has occurred in the projector, the error status is indicated by the indicator's color and combination of flashing or lit. Refer to the following table to see what the indicators mean and how to remedy problems that they indicate.





Indicator					Cause	Problem and solutions	LCD Display
Power	Status	Laser	Temp	Filter			
 Off	 Blue - Flashing	 Orange - Flashing	 Off	 Off	Internal Error	Make sure that the screws on the interface board are tightened securely. Turn off the projector, unplug the power plug from the outlet, and then remove and re-install the interface board. Special techniques are required to install and remove the interface board, so make sure you contact a specialist. If the error continues after checking the points above, stop using the projector, remove the power plug from the electrical outlet, and contact your local dealer or the nearest address provided in the Epson Projector Contact List.  Epson Projector Contact List	Internal Error
 Off	 Blue - Flashing	 Off	 Orange - Flashing	 Off	Fan Error Sensor Error Pump Error	Stop using the projector, remove the power plug from the electrical outlet, and contact your local dealer or the nearest address provided in the Epson Projector Contact List.  Epson Projector Contact List	Fan Error Sensor Error Pump Error
 Off	 Blue - Flashing	 Off	 Orange - On	 Off	High Temp Error (Overheating)	The light source turns off automatically and projection stops. Wait for about five minutes. After about five minutes, the projector switches to standby mode, so check the following four points. <ul style="list-style-type: none"> • Check that the Air filters, Air exhaust vent, and Air intake vent are clear, and that the projector is not positioned against a wall. • Check if the air intake temperature is too high. • If the air filter is clogged, remove the power cord from the electrical outlet, and then clean or replace them. <ul style="list-style-type: none">  "Cleaning the Air Filter and Air Intake Vent" p.204  "Replacing the Air Filter" p.208 • Use the projector in an environment that is not too hot. If the error continues after checking the points above, stop using the projector, remove the power plug from the electrical outlet, and contact your local dealer or the nearest address provided in the Epson Projector Contact List.  Epson Projector Contact List	Temp Error

Indicator					Cause	Problem and solutions	LCD Display
Power	Status	Laser	Temp	Filter			
						When using at an altitude of 1500 m or more, set High Altitude Mode to On . ☛ Extended - Operation - High Altitude Mode p.143	
Off	 Blue - Flashing	 Orange - On	Off	Off	Laser Error Retardation Plate Error	Stop using the projector, remove the power plug from the electrical outlet, and contact your local dealer or the nearest address provided in the Epson Projector Contact List. ☛ <i>Epson Projector Contact List</i>	Laser Error
Off	 Blue - Flashing	Off	Off	 Orange - On	Filter Airflow Error	Check the following two points. <ul style="list-style-type: none"> • Check that the air filter and air exhaust vents are clear, and that the projector is not positioned against a wall. • If the air filter is clogged, turn off the power, remove the power cord from the electrical outlet, and then clean or replace them. ☛ "Cleaning the Air Filter and Air Intake Vent" p.204 ☛ "Replacing the Air Filter" p.208 After checking, connect the power cord to the electrical outlet. If the error continues after checking the points above, stop using the projector, remove the power plug from the electrical outlet, and contact your local dealer or the nearest address provided in the Epson Projector Contact List. ☛ <i>Epson Projector Contact List</i>	Airflow Error
Off	 Blue - Flashing	 Orange - On	 Orange - On	Off	Lens Shift Error Supply Voltage Error	Stop using the projector, remove the power plug from the electrical outlet, and contact your local dealer or the nearest address provided in the Epson Projector Contact List. ☛ <i>Epson Projector Contact List</i>	Lens Error Power Error
Off	 Blue - Flashing	 Orange - On	 Orange - On	Off	Lens Error No Lens	Install the lens unit. If the lens unit is already installed, remove it and then reinstall it. If the error continues after checking the points above, stop using the projector, remove the power plug from the electrical outlet, and contact your local dealer or the nearest address provided in the Epson Projector Contact List. ☛ <i>Epson Projector Contact List</i>	Lens Error



Indicator					Cause	Problem and solutions	LCD Display
Power	Status	Laser	Temp	Filter			
 Off	 Blue - Flashing	 Orange - Flashing	 Orange - Flashing	 Off	Shutter Error	Stop using the projector, remove the power plug from the electrical outlet, and contact your local dealer or the nearest address provided in the Epson Projector Contact List.  Epson Projector Contact List	Shutter Error
 Blue - Flashing	 Status varies	 Status varies	 Orange - Flashing	 Status varies	High Temp Warning	This is not an error. However, if the temperature rises too high again, projection stops automatically. Check the following four points. <ul style="list-style-type: none"> • Check that the Air filters, Air exhaust vent, and Air intake vent are clear, and that the projector is not positioned against a wall. • Check if the air intake temperature is too high. • If the air filter is clogged, turn off the power, remove the power cord from the electrical outlet, and then clean or replace them. <ul style="list-style-type: none">  "Cleaning the Air Filter and Air Intake Vent" p.204  "Replacing the Air Filter" p.208 • Use the projector in an environment that is not too hot. 	Temp Warning
 Blue - Flashing	 Status varies	 Orange - Flashing	 Status varies	 Status varies	Laser Warning	Stop using the projector, remove the power plug from the electrical outlet, and contact your local dealer or the nearest address provided in the Epson Projector Contact List.  Epson Projector Contact List	Laser Warning
 Blue - Flashing	 Status varies	 Orange - Flashing	 Status varies	 Status varies	Lens Warning	An unsupported lens is attached. Use a supported lens.  "Optional Accessories and Consumables" p.236	Lens Error
 Blue - Flashing	 Status varies	 Orange - Flashing	 Status varies	 Status varies	Power Warning	The power voltage was not measured correctly, so the brightness of the light source has been dimmed. Contact your local dealer or the nearest address provided in the Epson Projector Contact List.  Epson Projector Contact List	Power Warning

Indicator					Cause	Problem and solutions	LCD Display
Power	Status	Laser	Temp	Filter			
 Blue - Flashing	 Status varies	 Orange - Flashing	 Orange - Flashing	 Status varies	Shutter Warning	Stop using the projector, remove the power plug from the electrical outlet, and contact your local dealer or the nearest address provided in the Epson Projector Contact List.  Epson Projector Contact List	Shutter Warning
 Blue - Flashing	 Status varies	 Status varies	 Status varies	 Orange - On	Low Air Flow	This is not an error. However, projection stops automatically if the airflow falls any further. The message "The air filter is clogged. Clean or replace the air filter." is displayed. Check the following two points. <ul style="list-style-type: none"> • Check that the air filter and air exhaust vents are clear, and that the projector is not positioned against a wall. • If the air filter is clogged, turn off the power, remove the power cord from the electrical outlet, and then clean or replace them. <ul style="list-style-type: none">  "Cleaning the Air Filter and Air Intake Vent" p.204  "Replacing the Air Filter" p.208 If the error continues after checking the points above, stop using the projector, remove the power plug from the electrical outlet, and contact your local dealer or the nearest address provided in the Epson Projector Contact List.  Epson Projector Contact List	Airflow Decline
 Status varies	 Status varies	 Status varies	 Status varies	 Orange - Flashing	Air Filter Notice	"Time to clean the air filter. Clean or replace the air filter." is displayed. Turn off the projector's power, unplug the power cord from the electrical outlet, and then clean the air filter.  "Cleaning the Air Filter and Air Intake Vent" p.204 The indicators or messages regarding air filter notice are displayed only when Air Filter Notice is set to On in the Configuration menu.  Extended - Display - Air Filter Notice p.143	Clean Filter
 Status varies	 Status varies	 Orange - Flashing	 Status varies	 Status varies	Constant Brightness End	Ends the Constant Brightness mode in Brightness Settings .  "Setting the Brightness" p.77	ConstBRT Expired

Wireless LAN status

WLAN indicator	Problem and solutions
 Blue - On	Wireless LAN is available.
 Flashing blue quickly	Connecting to device.
 Flashing blue slowly	An error has occurred. Turn the projector off and then on again.
 Off	Wireless LAN is un-available. Make sure the wireless LAN settings are correct.

Wired LAN/HDBaseT status

LAN indicator	Problem and solutions
 Blue - On	You can use a wired LAN or an HDBaseT transmitter.
 Off	You cannot use a wired LAN or an HDBaseT transmitter. Check that the wired LAN or HDBaseT transmitter settings are correct. Also, make sure that the LAN cable is connected correctly.



- See the following if the projector is not operating properly, even though the indicators are all showing normal.
 - ☛ "Problem Solving" [p.189](#)
- If the indicators are in a state not shown in this table, stop using the projector, remove the power plug from the electrical outlet, and contact your local dealer or the nearest address provided in the Epson Projector Contact List.
 - ☛ [Epson Projector Contact List](#)

The LCD on the control panel indicates the projector's status. Also, you can check the detailed status or error history of this projector by using the buttons on the control panel.

Checking the Status

To display the status, press the [>] button on the control panel.

There are eight display categories for the status, and each time you press the [>][<] buttons, the category switches in the following order.

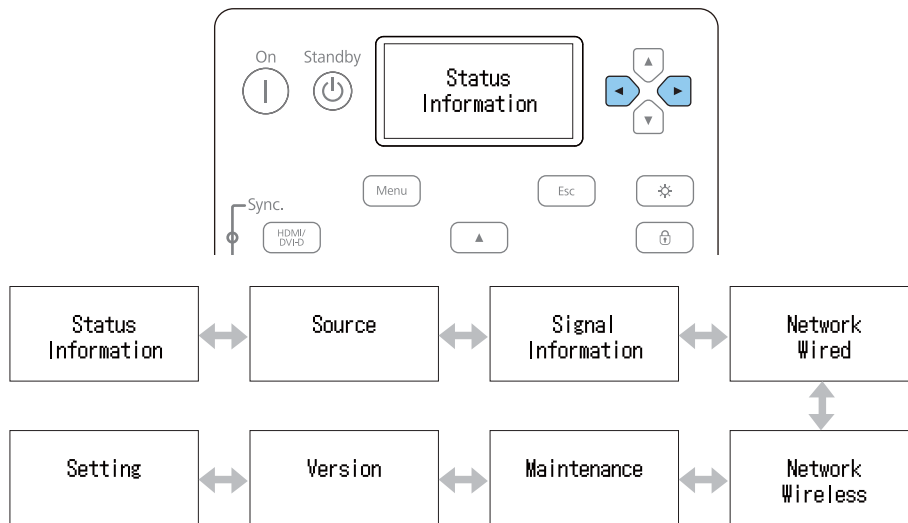

You can check the items and information of each category by using the [>][<] buttons.

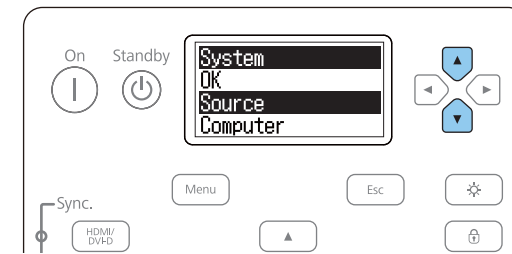

The LCD display turns on in the following situations.

- When one button is pressed on the control panel
- When an error or a warning occurs
- When adjusting the zoom, focus, or lens shift
- When checking the projector ID
 - "Checking the projector ID" [p.47](#)

Understanding the screen

Normal display

Each display category contains the following information.

- Status Information : Operating status of the projector
- Source : Input signal information
- Signal Information : Input digital signal information
- Network Wired : Wired LAN settings
- Network Wireless : Wireless LAN settings
- Maintenance : Operating time for the projector and light source
- Version : Projector's firmware version

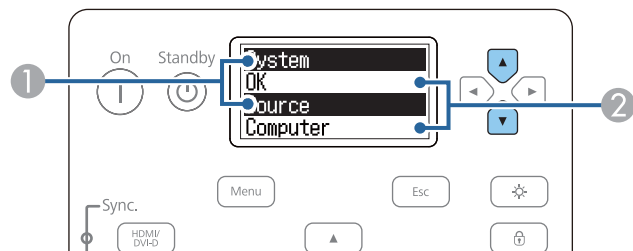

❶	Displays the item name. ☛ "Explanations of the Display Content" p.181
❷	Information about the items.

Display when error or warning occurs

When a problem has occurred in the projector, the following is displayed.

When an error occurs

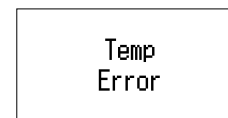

When a warning occurs

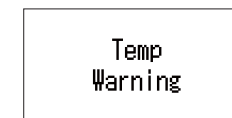

If the problem is cleared, or one of the [⏪][⏩][⏴][⏵] buttons is pressed, the display returns to normal.

See the following for more information on the error or warning contents and remedies.

☛ "Reading the Indicators" [p.171](#)

Setting the screen display (LCD)

You can adjust the contrast and the lighting time for the back light.

- 1 Press the [◀][▶] buttons to select **Setting**.

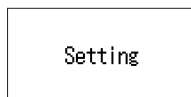

- 2 Press the [↓] button to display the following screen.

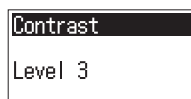

- 3 Press the [◀][▶] buttons to adjust the contrast.

- 4 Press the [↓] button to display the following screen.



- 5 Press the [◀][▶] buttons to set the lighting time for the back light.

The default is set to **30sec** (30 seconds). You can set from **Off** (light is off), **10-60sec**, **30min** (30 minutes), and **Always** (Always On).

Explanations of the Display Content

Items displayed vary depending on the model being used and the image signal and source being projected.

Category	Item	Status Display	Explanation
Status Information	System	Displays the projector's status. See the following for more information on errors or warnings displayed and remedies. ☛ "Reading the Indicators" p.171	
		OK	The projector is in normal status.
		Warm-Up	The projector is warming up.
		Standby	The projector is in standby status.
		Cool Down	The projector is in cool down status.
	Last Warn/Err	–	Displays the most recent warnings and errors for the status displayed in the System.
	Source	–	Displays the source name for the connected equipment currently being projected.
	On-Screen Display	On	Displays the settings for the On-Screen Display . When set to Off , the menus or messages are not displayed on the projected images.
		Off	
	Shutter	On	Displays the projector's Shutter function status.
		Off	
	Shutter Startup	Open	Displays the settings for Startup .
		Close	☛ Extended - Operation - Shutter Settings - Startup p.143
	Shutter Standby	Last Used	Displays the settings for Standby .
		Open	☛ Extended - Operation - Shutter Settings - Standby p.143
Close			
Intake Air Temp	–	Displays the air intake temperature. When you press the [◀][▶] buttons for five seconds, the Warning/Error Log screen is displayed. Press the [▶] button twice to display the Temp Log screen. Press the [▶][▶] buttons for five seconds to return to the Status Information screen.	
Internal Temp Lv	–	Displays the projector's internal temperature.	

Category	Item	Status Display	Explanation
Status Information	AC Voltage		<p>Monitors the status of the input voltage, and displays a warning or an error when a momentary voltage drop occurs.</p> <p>When you press the [◀][▶] buttons for five seconds, the Warning/Error Log screen is displayed. Press the [▶] button to display the Voltage Log screen.</p> <p>The Voltage Log screen displays the latest 30 logs.</p> <p>Example: 175V: Indicates that the voltage is 175 V. B50V: Indicates that the voltage is less than 50 V. ---V: Indicates that the voltage log cannot be measured.</p> <p>Press the [◀][▶] buttons for five seconds to return to the Status Information screen.</p> <p>Check the following if logs are not displayed correctly. 🖱️ "Detailed logs and error message" p.200</p>
		<Warning1>	<p>Voltage drops (when operating at 200 V): If the input voltage is less than 180 V for more than 1000 msec, logs (120) are displayed for approximately one second* before and after the issue occurred.</p> <p>Voltage drops (when operating at 100 V): If the input voltage is less than 89 V for more than 1000 msec, logs (120) are displayed for approximately one second* before and after the issue occurred.</p> <p>* The number of seconds varies according to the power supply frequency (50 Hz/60 Hz).</p>
		<Warning2>	<p>Voltage drops (when operating at 200 V): If the input voltage is less than 160 V for more than 500 msec, logs (120) are displayed for approximately one second* before and after the issue occurred.</p> <p>* The number of seconds varies according to the power supply frequency (50 Hz/60 Hz).</p>
		<Warning3>	<p>Power flicker: If the input voltage drops below 85 V for more than 40 msec, and the voltage returns within 60 msec, logs for approximately one second before the power flicker was detected (54 logs) and for approximately 0.1 seconds after (6 logs) are displayed.</p>
		<Error>	<p>Power cut: If the input voltage drops below 85 V for more than 60 msec, the projector is automatically disconnected from the power supply. Logs for approximately one second before the event was detected (60 logs) are displayed.</p> <p>When direct shutdown is enabled, an <Error> is generated when a direct shutdown is performed, however this is not an actual error.</p>

Category	Item	Status Display	Explanation
	Laser Status	On	Displays the operating status of the light source.
		Off	
Status Information	SLOT1 Model	–	Displays the product name for the interface board connected to Slot1.
	SLOT1 Condition	–	Displays the status for the interface board connected to Slot1.
	SLOT1 Board ID	–	Displays the ID for the interface board connected to Slot1.
	SLOT1 Board Ver	–	Displays the version for the interface board connected to Slot1.
	SLOT2 Model	–	Displays the product name for the interface board connected to Slot2.
	SLOT2 Condition	–	Displays the status for the interface board connected to Slot2.
	SLOT2 Board ID	–	Displays the ID for the interface board connected to Slot2.
	SLOT2 Board Ver	–	Displays the version for the interface board connected to Slot2.
Source	Source	–	Displays the source name for the connected equipment currently being projected.
	Resolution	–	Displays the resolution of the current input signal. No Signal: No signals are being input. Not Supported: The projector does not support the current input signal.
	Color Space	–	Displays the color space of the current input signal.
	H-Frequency	–	Displays the horizontal frequency of the current input signal.
	V-Frequency	–	Displays the vertical frequency of the current input signal.
	Sync Polarity	H:Posi / V:Posi	Displays the Sync polarity.
		H:Posi / V:Nega	
		H:Nega / V:Posi	
		H:Nega / V:Nega	
	Sync Mode	Composite Sync	Displays the sync type.
		Separate Sync	
Sync On Green			
Detected Mode	–	Displays the discriminant resolution of the current input signal.	
Transport	Interlace	Displays the scanning method.	
	Progressive		

Category	Item	Status Display	Explanation
	Video Range	Auto(Limited)	Displays the video level of the projector.
		Auto(Full)	
		Limited(16-235)	
		Full(0-255)	



Items displayed for source vary depending on the model being used and the image signal and source being projected.

Category	Item	Status Display	Explanation
Signal Information	5V Detect	Detected	Displays the detection results of 5V signals.
		Not Detected	
	TMDS Clock	–	Displays the TMDS frequency of the current input signal.
	H-Frequency	–	Displays the horizontal frequency of the current input signal.
	V-Frequency	–	Displays the vertical frequency of the current input signal.
	DetChg 5CFHMP123	–	Displays the factors of signal changes.
	Stable Time	–	Displays the operating time since the input source is determined.
	HDCP Status	Non-HDCP	Displays the HDCP status.
		Passed	
		Failed	
	HDCP Ver	–	Displays the HDCP version.
	AVI VIC	–	Displays the VIC information (AVI) of the current input signal.
	AVI Checksum	OK	Displays the checksum result for AVI.
		NG	
	AVI Sampling Str	RGB4:4:4	Displays color sampling for AVI.
		YCbCr4:4:4	
		YCbCr4:2:2	
		YCbCr4:2:0	
	Signal Mode	HDMI	Displays the signal mode.
		DVI	
Color Space	–	Displays the color space conversion method.	
HDR Mode	–	Displays the HDR mode.	
EDID Mode	–	Displays the EDID mode.	
HDBaseT Level	–	You can display the image signal information from the HDBaseT port.	
SDI Link Mode	–	Displays the linking type for SDI.	
Sync Detect	–	Displays the results of signal detection for each SDI port.	

Category	Item	Status Display	Explanation
	PayloadID Detect	–	Displays the results of SDI payload ID detection.

Category	Item	Status Display	Explanation
Signal Information	Resolution	–	Displays the resolution.
	Refresh Rate	–	Displays the refresh rate for SDI.
	Color Sampling	–	Displays the color sampling.
	Pixel Depth	–	Displays the color depth for SDI.
	SDI Type	–	Displays the type of SDI.
	Division Type	–	Displays the split transmission method for SDI.
	3G Mapping Level	–	Displays the mapping level for 3G-SDI.
	Stream No. CH1/2	–	Displays the input payload ID information for the SDI1 In port or the SDI2 In port, or displays the setting for the Configuration menu.
	Stream No. CH3/4	–	Displays the input payload ID information for the SDI3 In port or the SDI4 In port, or displays the setting for the Configuration menu.
	Cable Detect	–	Displays the detection results of the AUX channel for DisplayPort.
Pixel Clock	–	Displays the frequency of the DisplayPort image signal.	



Items displayed for Signal Information vary depending on the model being used and the image signal and source being projected.











Category	Item	Status Display	Explanation
Network Wired	Projector Name	–	Displays the projector name used to identify the projector when connected to a network.
	Connection Mode	HDBaseT	Displays the connection path for LAN.
		LAN	
	DHCP	On	Displays the DHCP settings.
		Off	
	IP Display	On	Displays the IP address display settings.
		Off	
IP Address	–	Displays the IP address.	
MAC Address	–	Displays the MAC address.	
Network Wireless	Projector Name	–	Displays the projector name used to identify the projector when connected to a network.
	Connection Mode	Quick	Displays the connection mode to use when connecting the projector and a computer over a wireless LAN.
		Advanced	
	SSID Display	On	Displays the SSID display settings.
		Off	
	IP Display	On	Displays the IP address display settings.
		Off	
	SSID	–	Displays the SSID.
	IP Address	–	Displays the IP address.
	DHCP	On	Displays the DHCP settings.
		Off	
MAC Address	–	Displays the MAC address.	
Security	–	Displays the security settings.	
Antenna Level	LEVEL 0-5	Displays the reception status for Wi-Fi.	



Category	Item	Status Display	Explanation
Maintenance	Operation Time	–	Displays the total operation time of the projector.
	Laser Op.Time	–	Displays the laser operating time for each setting in Light Source Mode.
Version	Serial No.	–	Displays the projector's serial number.
	Main	–	Displays the projector's firmware version information.
	Video2	–	
	Sub	–	
	Sub2	–	
	HDBaseT	–	
	Status Monitor	–	

If any of the following problems occur and the indicators do not offer a solution, refer to the pages given for each problem.

Problems Relating to Images









<ul style="list-style-type: none"> • No images appear Projection does not start, the projection area is completely black, or the projection area is completely blue. 	 p.190
<ul style="list-style-type: none"> • Moving images are not displayed Videos played back on a computer are black or no image is projected, or the video is not played back on the computer. 	 p.191
<ul style="list-style-type: none"> • Projection stops automatically 	 p.191
<ul style="list-style-type: none"> • The message "Not supported" is displayed 	 p.191
<ul style="list-style-type: none"> • "No Signal" is displayed 	 p.191
<ul style="list-style-type: none"> • Images are fuzzy, out of focus, or distorted 	 p.192
<ul style="list-style-type: none"> • Interference or distortion appear in images 	 p.192
<ul style="list-style-type: none"> • The image is truncated (large) or small, the aspect ratio is not suitable, or the image has been reversed Only part of the image is displayed, the height and width ratios of the image are not correct, or the image may appear reversed from top to bottom or left to right. 	 p.193
<ul style="list-style-type: none"> • Image colors are not right The whole image appears purplish or greenish, images are black & white, or colors appear dull. 	 p.194
<ul style="list-style-type: none"> • Images appear dark 	 p.195
<ul style="list-style-type: none"> • Automatic adjustments are not performed correctly 	 p.195

Problems when Projection Starts

<ul style="list-style-type: none"> • The projector does not turn on 	 p.196
---	---

Other Problems

<ul style="list-style-type: none"> • The remote control does not work 	 p.197
---	---

<ul style="list-style-type: none"> • Cannot control correctly using Art-Net 	 p.198
<ul style="list-style-type: none"> • Nothing appears on the external monitor 	 p.199
<ul style="list-style-type: none"> • I want to change the language for messages and menus 	 p.199
<ul style="list-style-type: none"> • Email is not received even if a problem occurs in the projector 	 p.199
<ul style="list-style-type: none"> • "The battery that saves your clock settings is running low." is displayed 	 p.199
<ul style="list-style-type: none"> • "The projector did not turn off correctly." is displayed 	 p.200
<ul style="list-style-type: none"> • Detailed logs and error message are not displayed 	 p.200
<ul style="list-style-type: none"> • "An error occurred in the interface board." is displayed 	 p.200

Problems Relating to Images

No images appear

Check	Remedy
Is the main power switch set to Off?	Turn on the main power switch to supply power to the projector.
Did you press the [ⓘ] button on the remote control or control panel?	Press the [ⓘ] button to turn on the power.
Are the indicators switched off?	The power cord is not connected correctly or power is not being supplied. Connect the projector's power cord correctly. Check that your electrical outlet or power source is functioning correctly.
Is Shutter active?	Press the [Shutter] button to release the Shutter function. ☛ "Hiding the Image Temporarily (Shutter)" p.102
Are the Configuration menu settings correct?	Reset all of the settings. ☛ Reset - Reset All Config p.159
Is the image to be projected completely black? (Only when projecting computer images)	Some input images, such as screen savers, may be completely black.
Is Windows Media Center displayed in full screen? (Only during network connection)	When Windows Media Center is displayed at full screen, you cannot project using a network connection. Reduce the screen size.
Is an application using the Windows DirectX function displayed? (Only during network connection)	Applications using the Windows DirectX function may not display images correctly.
Are you using any other image display equipment with the projector?	Other image display equipment may have a different resolution. Change the EDID setting on the Signal menu. ☛ Signal - Advanced - EDID p.138
Is the signal from the SDI In port set correctly?	Check the SDI Settings from the Configuration menu. ☛ Extended - SDI Settings p.143
Is the signal from the DisplayPort set correctly?	Check the DisplayPort Settings from the Configuration menu. Try changing the Link Type setting when connecting two cables and inputting signals. ☛ Extended - DisplayPort Settings p.143
Is the EDID set correctly?	Disconnect the cable for the image currently being projected from the projector, and then make EDID settings again. ☛ Signal - Advanced - EDID p.138

Moving images are not displayed

Check	Remedy
Is the computer's image signal being output to the LCD and the monitor? (Only when projecting images from a laptop computer or a computer with a built-in LCD screen)	Change the image signal from the computer to external output only. Check your computer's documentation, or contact the computer's manufacturer.
Are the contents of the moving image you are trying to project copyright protected?	The projector may not be able to project copyright protected moving images that are being played back on a computer. For more details, see the user's guide supplied with the player.

Projection stops automatically

Check	Remedy
Is Sleep Mode set to On ?	Press the [ⓘ] button to turn on the power. If you do not want to use Sleep Mode, change the setting to Off . ☛ Extended - Operation - Sleep Mode p.143

"Not supported" is displayed

Check	Remedy
Do the image signal resolution and the refresh rate correspond to the mode? (Only when projecting computer images)	Refer to the computer's documentation for how to change the image signal resolution and the refresh rate output from the computer. ☛ "Supported Monitor Displays" p.246

"No Signal" is displayed

Check	Remedy
Are the cables connected correctly?	Check that all the cables required for projection are securely connected. Check that no cables are disconnected and that there are no poor contacts in the cables.
Is the correct port selected?	Change the image by pressing the [Search] button. ☛ "Changing the Projected Image" p.62
Is the power for the computer or video source turned on?	Turn the power on for the equipment.

Check	Remedy
<p>Are the image signals being output to the projector? (Only when projecting images from a laptop computer or a computer with a built-in LCD screen)</p>	<p>If the image signals are only being output to the computer's LCD monitor or to the accessory monitor, you need to change the output to an external destination as well as the computer's own monitor. For some computer models, when the image signals are output externally, they no longer appear on the LCD monitor or accessory monitor.</p> <p>If the connection is made while the power of the projector or computer is already turned on, the Fn key (Function key) that changes the computer's image signal to external output may not work. Turn the power for the computer and the projector off and then back on again.</p> <p>☛ Computer's documentation and so on</p>

Images are fuzzy, out of focus, or distorted

Check	Remedy
<p>Is the focus adjusted correctly?</p>	<p>Make sure that at least 30 minutes has passed after the projection starts, and press the [Focus] button on the remote control to adjust the focus.</p> <p>☛ "Correcting the Focus" p.41</p>
<p>Is the projector at the correct distance?</p>	<p>Is it projecting outside of the recommended projection distance range? Setup within the recommended range.</p> <p>☛ "Screen Size and Projection Distance" p.237</p>
<p>Has condensation formed on the lens?</p>	<p>If the projector is suddenly taken from a cold environment to a warm environment, or if sudden ambient temperature changes occur, condensation may form on the surface of the lens, and this may cause the images to appear fuzzy. Set the projector up in the room about one hour before it is used. If condensation forms on the lens, turn the projector off and wait for the condensation to disappear.</p>

Interference or distortion appear in images

Check	Remedy
<p>Are the cables connected correctly?</p>	<p>Check that all the cables required for projection are securely connected.</p> <p>☛ "Connecting Equipment" p.51</p>
<p>Is an extension cable being used?</p>	<p>If an extension cable is used, electrical interference may affect the signals. Use the cables supplied with the projector to check if the cables you are using may be causing the problem.</p>

Check	Remedy
Is the correct resolution selected? (Only when projecting computer images)	Set the computer so that the signals being output are compatible with the projector. ☛ "Supported Monitor Displays" p.246 ☛ Computer's documentation and so on
Is the Sync./Tracking adjusted correctly? (Only when projecting computer images)	Press the [Auto] button on the Remote Control or the [↵] button on the Control panel to perform automatic adjustment. If the images are not adjusted correctly even after performing automatic adjustment, you can also make adjustments from the Configuration menu. ☛ Signal - Tracking, Sync. p.138
Is the Resolution set to anything other than Auto ? (Only when projecting on a split screen)	The image may be collapsed if the Resolution on the Configuration menu and the resolution of the projected image are not the same. If the image is collapsed, set the Resolution to Auto . ☛ Signal - Resolution p.138

The image is truncated (large) or small, the aspect is not suitable, or the image has been reversed

Check	Remedy
Have the Screen been set correctly?	Make the appropriate Screen for the screen being used. ☛ "Screen Settings" p.36
Is the aspect adjusted correctly?	Press the [Aspect] button to select an aspect suitable for the input source. ☛ "Changing the Aspect Ratio of the Projected Image" p.80
Is Scale turned on?	Set Scale to Off on the configuration menu. ☛ Signal - Scale - Scale p.138
Is the display range restricted by Blanking ?	Appropriately set Blanking in the configuration menu. ☛ Signal - Blanking p.138
Is the image position adjusted correctly?	(Only when projecting analog RGB signals input from the Computer In port) Press the [Auto] button on the remote control or the [↵] button on the control panel to adjust the position. You can also adjust the position from the Configuration menu. ☛ Signal - Position p.138
Is the computer set for dual display? (Only when projecting computer images)	If dual display is activated in the Display Properties of the computer's Control Panel, only about half of the image on the computer screen is projected. To display the entire image on the computer screen, turn off the dual display setting. ☛ Computer video driver's documentation

Check	Remedy
Is the correct resolution selected? (Only when projecting computer images)	Set the computer so that the signals being output are compatible with the projector. <ul style="list-style-type: none"> ☛ "Supported Monitor Displays" p.246 ☛ Computer's documentation and so on
Is the image direction correct?	Make the correct settings in Projection from the Configuration menu. <ul style="list-style-type: none"> ☛ "Installation Settings" p.35

Image colors are not right

Check	Remedy
Do the input signal settings match the signals from the connected device?	Change the setting according to the signal for the connected equipment. <ul style="list-style-type: none"> ☛ Signal - Advanced - Input Signal p.138
Is the image brightness adjusted correctly?	Adjust the Brightness setting from the Configuration menu. <ul style="list-style-type: none"> ☛ Image - Brightness p.137
Are the cables connected correctly?	Check that all the cables required for projection are securely connected. Check that no cables are disconnected and that there are no poor contacts in the cables. <ul style="list-style-type: none"> ☛ "Connecting Equipment" p.51
Is the Contrast adjusted correctly?	Adjust the Contrast setting from the Configuration menu. <ul style="list-style-type: none"> ☛ Image - Contrast p.137
Is the color adjustment set correctly?	Adjust the Gamma or RGBCMY setting from the Configuration menu. <ul style="list-style-type: none"> ☛ Image - Advanced p.137 ☛ "Adjusting the Image" p.81
Are the color saturation and tint adjusted correctly?	Adjust the Color Saturation and Tint settings from the Configuration menu. <ul style="list-style-type: none"> ☛ Image - Color Saturation, Tint p.137
Is the brightness of the room appropriate?	If the room is darker than when the auto adjustment was performed, the tint of the projected images may not be displayed correctly. Make the room darker and then perform auto adjustment again. <ul style="list-style-type: none"> ☛ "Screen Matching" p.94 ☛ "Color Calibration" p.210



Check	Remedy
Are you projecting from multiple projectors at the same time?	<p>Make sure that Light Source Calibration from the Reset menu is set correctly for all of the projectors. If Light Source Calibration is only executed for some of the projectors, there may be differences between the White Balance or the Brightness Level.</p> <p>If you perform Screen Matching regularly, make sure you execute Screen Matching after performing Light Source Calibration. If there are still differences in the color, set Light Source Calibration to Off.</p>

Images appear dark

Check	Remedy
Is the image brightness set correctly?	<p>Check the Brightness and Brightness Settings values from the Configuration menu.</p> <ul style="list-style-type: none"> ☛ Image - Brightness p.137 ☛ Settings - Brightness Settings p.141
Is the Contrast adjusted correctly?	<p>Adjust the Contrast setting from the Configuration menu.</p> <ul style="list-style-type: none"> ☛ Image - Contrast p.137
Is only one projector being used?	<p>Check if the following item is set to dark.</p> <ul style="list-style-type: none"> ☛ Extended - Multi-Projection - Screen Matching - Brightness Settings p.143
Is the HDR adjusted correctly?	<p>Adjust HDR10 Setting and HLG Setting from the Configuration menu.</p> <ul style="list-style-type: none"> ☛ Signal - Dynamic Range - HDR10 Setting, HLG Setting p.138
Is the video level adjusted correctly?	<p>Check the Video Range from the Configuration menu.</p> <ul style="list-style-type: none"> ☛ Signal - Dynamic Range - Advanced - Video Range p.138

Automatic adjustments are not performed correctly

Check	Remedy
Have at least 30 minutes passed since the power was turned on?	Auto adjustment does not work correctly until the temperature of the projector is stable. Perform auto adjustment 30 minutes after turning on the projector or canceling Shutter.
Is the cover of the built-in camera clean?	Make sure that the cover of the built-in camera is clean. Clean the cover if it is dirty.
Was auto correction performed while the protection plate was attached to the built-in camera?	Remove the protection plate.

Check	Remedy
Are you using a lens that does not support specific operations?	Auto adjustment is not available when using the following lenses. <ul style="list-style-type: none"> • Screen Matching, Tiling Assist ELPLX02, ELPLX02W, ELPLU02, ELPLU03, ELPLU03S, ELPLU04, ELPLL07, ELPLL08, ELPLR04 • Color Calibration ELPLX02, ELPLX02W, ELPLR04, ELPLL07, ELPLL08
Is an analog signal being input?	When inputting an analog signal, the color and brightness of the input image changes, and the results of adjustment may not be applied correctly.
Has the image been corrected using Geometry Correction?	If the angle of projection onto the screen is too large, auto correction may not work correctly for images corrected using Geometry Correction. Set Geometry Correction to Off or reduce the correction range.  Settings - Geometry Correction p.141
Is the brightness of the surroundings appropriate?	If a powerful spotlight or natural light shines into the area during auto adjustment, the brightness of the surroundings changes and auto adjustment does not operate correctly. Make sure the brightness of the surroundings does not change.
Is the blending width appropriate?	If the blending width in Edge Blending exceeds the following range, auto correction may not work properly. Check the blending width. <ul style="list-style-type: none"> • Screen Matching 15 to 45% • Tiling Assist: 15 to 43%  Extended - Multi-Projection - Edge Blending p.143
Is the message "An error occurred during auto adjustment." displayed?	The following items explain the error codes displayed in the message. <ul style="list-style-type: none"> • During Screen Matching: 0101 Measurement value error; 0102 Measurement failure; 0103 Switch camera failure • During Color Matching: 0201 Measurement value error; 0202 Measurement failure; 0203 Switch camera failure For more details, contact your local dealer or the nearest address provided in the Epson Projector Contact List.  Epson Projector Contact List

Problems when Projection Starts

The projector does not turn on

Check	Remedy
Is the main power switch set to Off?	Turn on the main power switch to supply power to the projector.
Did you press the [ⓘ] button on the remote control or control panel?	Press the [ⓘ] button to turn on the power.

Check	Remedy
Are the indicators switched off?	The power cord is not connected correctly or power is not being supplied. Disconnect and then reconnect the power cord. Check that your electrical outlet or power source is functioning correctly.
Do the indicators turn on and off when the power cord is touched?	There is probably a poor contact in the power cable, or the power cable may be defective. Reinsert the power cable. If this does not solve the problem, stop using the projector, disconnect the power cable from the electrical outlet, and contact your local dealer or the nearest address provided in the Epson Projector Contact List. ☛ Epson Projector Contact List
Is the Control Panel Lock set to Full Lock ?	Press the [ⓘ] button on the remote control. If you do not want to use Control Panel Lock , change the setting to Off . ☛ "Control Panel Lock" p.113
Is the correct setting for the remote receiver selected?	Check the Remote Receiver from the Configuration menu. ☛ Settings - Remote Receiver p.141
Was the power cord plugged back in or was the breaker turned on immediately after direct shutdown?	If the operation described in the column on the left is performed when Direct Power On is set to On , the power may not turn back on. Press the [ⓘ] button to turn on the power.
Is the [ID] switch on the remote control set to On?	When the switch is set to On, you can use the remote control to operate only a projector with a matching ID. Set the [ID] switch to Off. ☛ "Setting the remote control ID" p.47

Other Problems

The remote control does not work

Check	Remedy
Is the remote control light-emitting area pointing towards the remote receiver on the projector during operation?	Point the remote control towards the remote receiver. ☛ "Remote control operating range" p.28
Is the remote control too far from the projector?	Check the operating range. ☛ "Remote control operating range" p.28
Is direct sunlight or strong light from fluorescent lamps shining onto the remote receiver?	Set the projector up in a location where strong light does not shine onto the remote receiver.

Check	Remedy
Is the correct setting for the Remote Receiver selected?	Check the Remote Receiver from the Configuration menu. ☛ Settings - Remote Receiver p.141
Are the batteries dead or have the batteries been inserted correctly?	Make sure the batteries are inserted correctly or replace the batteries with new ones if necessary. ☛ "Replacing the remote control batteries" p.27
Are the remote control ID and the projector ID matched?	Make sure the ID for the projector you want to operate and the ID for the remote control match. To operate all projectors by remote control regardless of the ID setting, set the [ID] switch on the remote control to Off. ☛ "ID Settings" p.46
Is the optional remote control cable connected to the projector's Remote port?	When the remote control cable is connected, the projector's remote receiver is disabled. When not using the remote control cable set, disconnect it from the Remote port.
Is Control Communications or Extron XTP set to On ?	The Remote port is disabled. When using the optional remote control cable set, set Control Communications or Extron XTP to Off . ☛ Extended - HDBaseT p.143
Is the remote control button lock set?	When the remote control button lock is set, buttons except for those needed for basic remote control operations are deactivated. Hold down the [] button to cancel the remote control button lock. ☛ "Remote control button lock" p.114

Cannot control correctly using Art-Net

Check	Remedy
While controlling the projector using Art-Net, did you operate the projector using the remote control or control panel?	While controlling the projector using Art-Net and performing operations from the remote control or control panel, settings made by the DMX controller or application software may not be applied to the projector correctly. When you want to apply all the channel controls to the projector, set Channel 13 to "Cannot control", then set it back to "Can control". ☛ "About Art-Net" p.230

Nothing appears on the external monitor

Check	Remedy
Are you projecting a split screen?	Only RGB signals projected on the left screen from the Computer In port can be displayed on an external monitor. ☛ "Projecting Two Images Simultaneously (Split Screen)" p.100
Is the projector in standby mode?	No images are input when the projector is in standby mode.

I want to change the language for messages and menus

Check	Remedy
Change the Language setting.	Adjust the Language setting from the Configuration menu. ☛ Extended - Language p.143

Email is not received even if a problem occurs in the projector

Check	Remedy
Is Standby Mode set to Communication On ?	To use the Mail Notification function when the projector is in standby, set Communication On in Standby Mode from the Configuration menu. ☛ Extended - Standby Mode p.143
Is power being supplied to the projector?	Check that your electrical outlet or power source is functioning correctly.
Is the Mail Notification function set correctly in the Configuration menu?	An error notification email is sent according to the Notifications settings in the Configuration menu. Check if it is set correctly. ☛ "Notifications menu" p.155

"The battery that saves your clock settings is running low." is displayed

Check	Remedy
The internal power supply that saves your clock settings is running low.	Contact your local dealer or the nearest address provided in the Epson Projector Contact List. ☛ Epson Projector Contact List

"The projector did not turn off correctly." is displayed

Check	Remedy
Is direct shutdown enabled or did the voltage drop due to a sudden blackout?	Check detailed logs in the status monitor. ☛ "Understanding the Status Information" p.178

Detailed logs and error message are not displayed





Check	Remedy
Depending on the environment, errors and warnings may not be displayed when turning on the projector after a sudden voltage drop, blackout, or power cut.	Wait for at least 10 seconds after turning off the main power switch or unplugging the power cable. Next, turn the main power switch back on or plug in the power cable. If the projector turns on, check the status monitor.

"An error occurred in the interface board." is displayed

Check	Remedy
You may need to replace the interface board for the slot indicated in the message.	See the following for more information on the error or warning contents and remedies. ☛ "Reading the Indicators" p.171 If the error continues after checking the points above, contact your local dealer or the nearest address provided in the Epson Projector Contact List. ☛ Epson Projector Contact List

Check the numbers and then apply the following countermeasures. If you cannot resolve the problem, contact your network administrator, or contact your local dealer or the nearest address provided in the Epson Projector Contact List.

 [Epson Projector Contact List](#)

Event ID	Cause	Remedy
0432 0435	Failed to start the network software.	Restart the projector.
0434 0481 0482 0485	Network communication is unstable.	Check the network communication status, and reconnect after waiting for a while.
0433	Cannot play transferred images.	Restart the network software.
0484	Communication was disconnected from the computer.	
0483 04FE	The network software ended unexpectedly.	Check the status of network communications. Restart the projector.
0479 04FF	A system error occurred in the projector.	Restart the projector.
0891	Cannot find an access point with the same SSID.	Set the computer, the access point, and the projector to the same SSID.
0892	The WPA/WPA2 authentication type does not match.	Check that the wireless LAN security settings are correct.
0893	The TKIP/AES encryption types do not match.	 Network - Wireless LAN p.151
0894	Communication was disconnected because the projector connected to an unauthorized access point.	Contact your network administrator for more information.
0898	Failed to acquire DHCP.	Check that the DHCP server is operating correctly. If you are not using DHCP, turn off the DHCP setting.  Network - Wireless LAN p.151 , Wired LAN p.155
0899	Other communication errors	If restarting the projector or network software does not solve the problem, contact your local dealer or the nearest address provided in the Epson Projector Contact List.  Epson Projector Contact List
089A	The EAP authentication type is not the same.	Check that the wireless LAN security settings are correct. Also, check if the certificate is installed correctly.  Network - Wireless LAN p.151
089B	EAP server authentication failed.	
089C	EAP client authentication failed.	



Event ID	Cause	Remedy
089D	Key exchange failed.	
0920	The internal power supply that saves your clock settings is running low.	Contact your local dealer or the nearest address provided in the Epson Projector Contact List.  Epson Projector Contact List



Maintenance

This chapter provides information on maintenance procedures to ensure the best level of performance from the projector for a long time to come.

You should clean the projector if it becomes dirty or if the quality of projected images starts to deteriorate.

Caution

When cleaning, turn off the main power switch, and then unplug the power cord from the electric outlet. Otherwise, it could cause an electric shock.

Attention

We recommend cleaning the inside of the projector once a year. If the inside of the projector is not cleaned for a long time, dust collects which could cause a fire or electric shock.

Cleaning the Projector

Clean the projector's surface by wiping it gently with a soft cloth.

If the projector is particularly dirty, moisten the cloth with water containing a small amount of neutral detergent, and then firmly wring the cloth dry before using it to wipe the projector's surface.

Attention

Do not use volatile substances such as wax, alcohol, or thinner to clean the projector's surface. The quality of the case may change or become discolored.

Cleaning the Lens

Clean any dirt on the lens wiping it gently with a soft, dry cloth.

Warning

Do not use sprays that contain flammable gas to remove dust and lint from the lens. The projector may catch fire due to the high internal temperature.

Use a vacuum cleaner or a hand-held air blower to remove any dust and lint attached to the lens.

Attention

Do not rub the lens with harsh materials or subject the lens to shocks, as it can easily become damaged.

Cleaning the Air Filter and Air Intake Vent

When the following message is displayed and the filter indicator flashes orange, clean the air filter and the air intake vent.

"Time to clean the air filter. Clean or replace the air filter."

"The projector is overheating. Make sure nothing is blocking the air vent, and clean or replace the air filter."

The message "The air filter is clogged. Clean or replace the air filter."

Warning

Do not use sprays that contain flammable gas to remove dust and lint from the filter.

The projector may catch fire due to the high internal temperature. Use a vacuum cleaner or a hand-held air blower to remove any dust and lint attached to the air filter and so on.

Attention

- If dust collects on the air filter, it can cause the internal temperature of the projector to rise, and this can lead to problems with operation and shorten the optical engine's service life. Clean the air filter immediately when the message is displayed.
- Do not rinse the air filter in water. Do not use detergents or solvents.
- When using a brush for cleaning, use one with long soft bristles, and brush it lightly. If it is brushed too strongly, dust will be ground into the air filter and cannot be removed.



When using a projector with an air filter on the ceiling side, the air filter will become clogged frequently.

Cleaning the air filter

This projector has two air filters on the front (see the following illustration). This explanation uses cleaning the air filter on the right as an example.

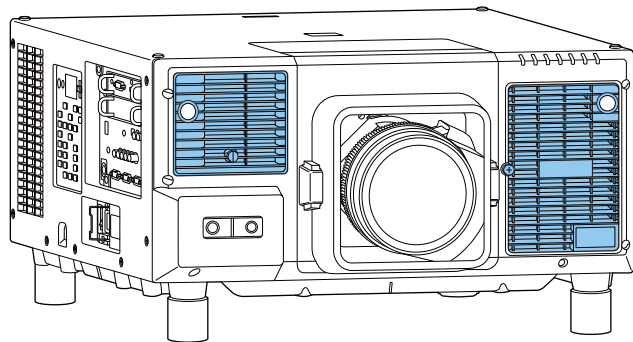

- 1** After you turn off the projector's power and the confirmation buzzer beeps, disconnect the power cord.
- 2** Loosen the fixing screw and open the air filter cover.

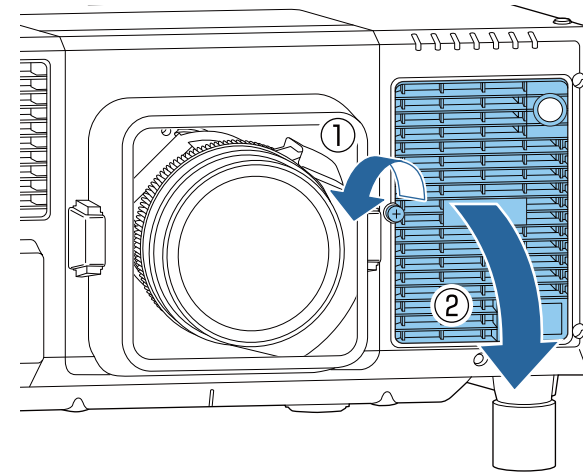

- 3** Remove the air filter.
Grip the tab of the air filter, and pull it straight out.

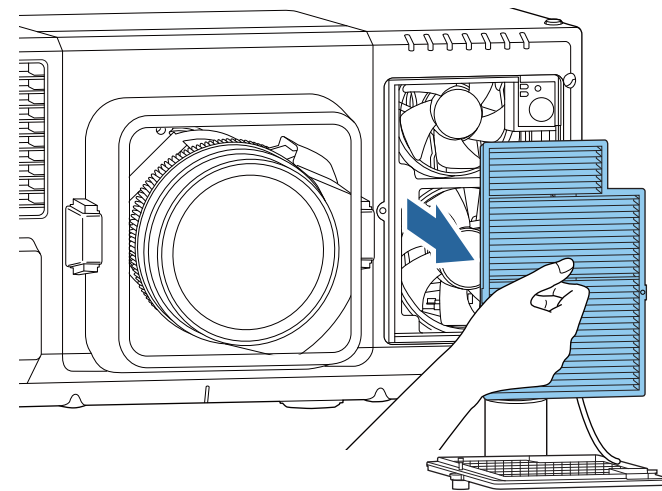

- 4** With the front (the side with tabs) of the air filter facing down, tap the air filter four or five times to shake off the dust. Turn it over and tap the other side in the same way.

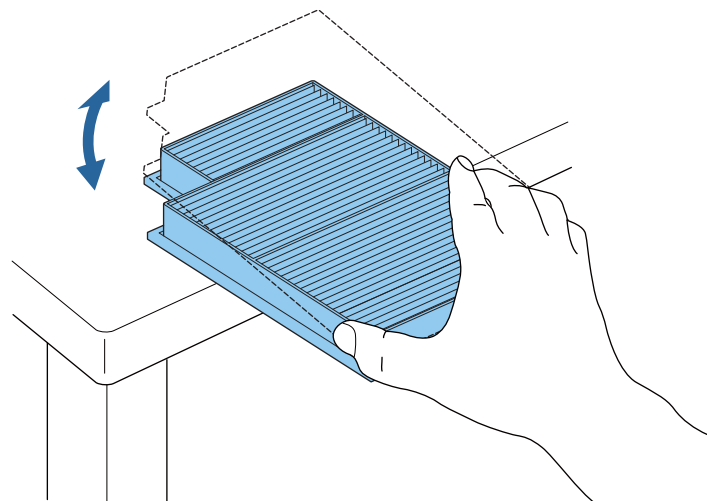

Attention

If the air filter is hit too hard, it may become unusable due to deformities and cracks.

- 5** Remove any dust remaining on the air filter by using a vacuum cleaner from the front side.

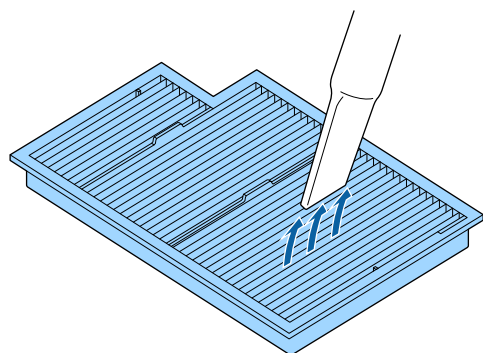

- 6** Replace the air filter.
Press until it clicks into place.

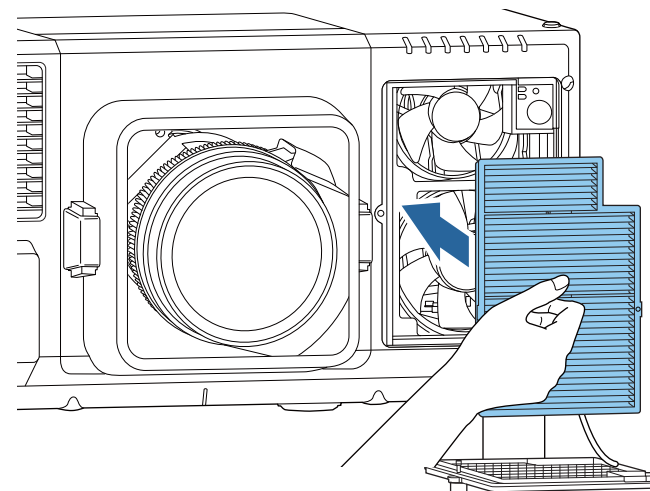

- 7** Close the air filter cover and tighten the fixing screw.

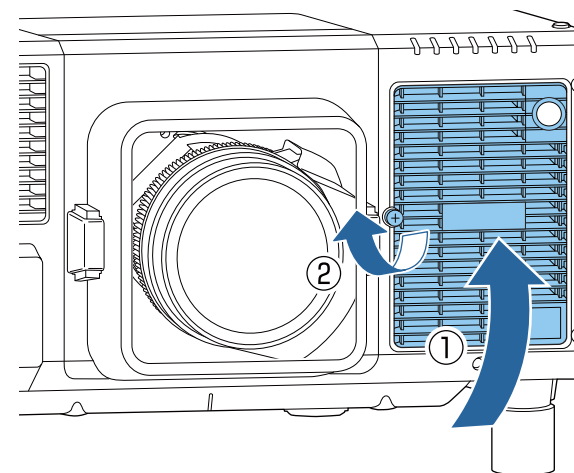



- If a message is frequently displayed, even after cleaning, it is time to replace the air filter. Replace it with a new air filter.
 - ☛ "Replacing the Air Filter" [p.208](#)
- It is recommended that you clean the air filter every 20,000 hours. Clean it more often than this if using the projector in a particularly dusty environment.
- The indicators or messages regarding Air Filter Notice are displayed only when **Air Filter Notice** is set to **On** from the Configuration menu.
 - ☛ **Extended - Display - Air Filter Notice** [p.143](#)

- 1** After you turn off the projector's power and the confirmation buzzer beeps, disconnect the power cord.
- 2** Use a vacuum cleaner or a soft brush to carefully remove the dust.

Cleaning the air intake vent

Clean off any dust that adheres to the air intake vents on the side and bottom of the projector.

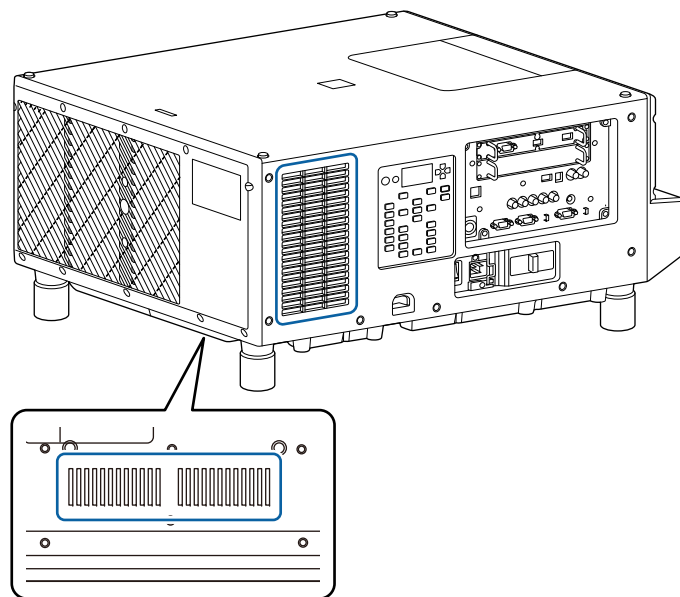

This section explains how to replace the air filter.

Replacing the Air Filter

Air filter replacement period

If the message is displayed frequently even though the air filter has been cleaned, replace the air filter.

Attention

When using the projector in smoky environments such as at events and so on, make sure you replace the air filter after approximately 240 hours of use. (This is a guideline when using the projector in an environment with an atmospheric concentration of ondina oil of approximately 0.00000013%. The air filter replacement time may be shorter depending on the operating environment.)

Using the projector in a smoky environment may cause the filter's dust collection function to decline and dust may adhere to the inside of the projector or the power supply; this may cause a malfunction to occur.

Replacing the air filter

This projector has two air filters on the front. This explanation uses replacing the air filter on the right as an example.

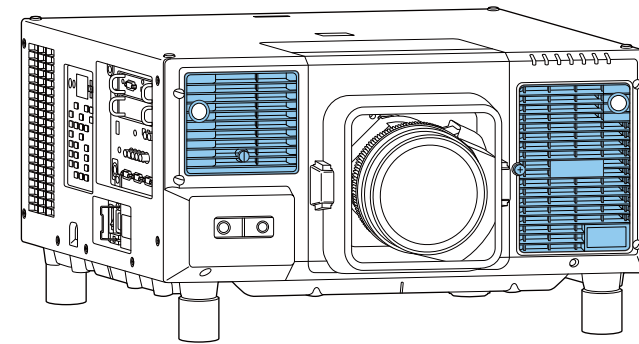

1 After you turn off the projector's power and the confirmation buzzer beeps, disconnect the power cord.

2 Loosen the fixing screw and open the air filter cover.

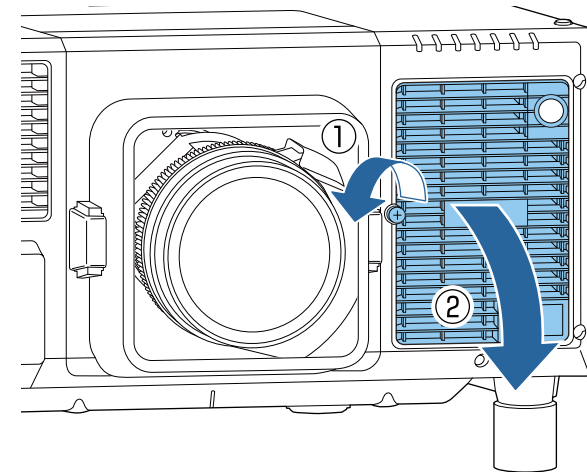

3 Remove the air filter.
Grip the tab of the air filter, and pull it straight out.

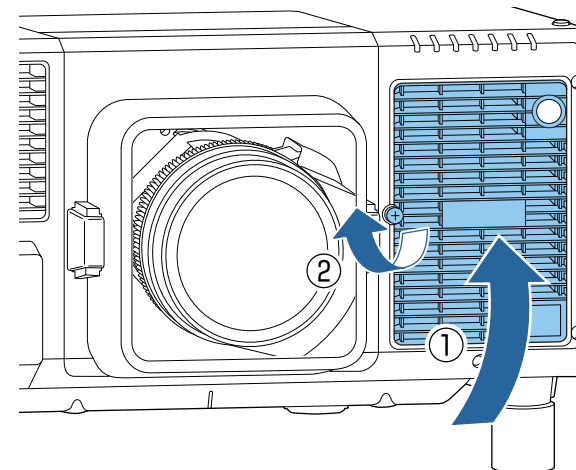
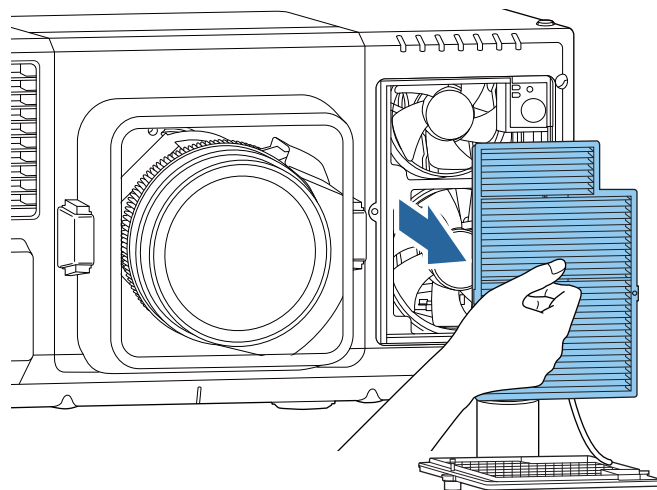

- 4** Install the new air filter.
Press until it clicks into place.

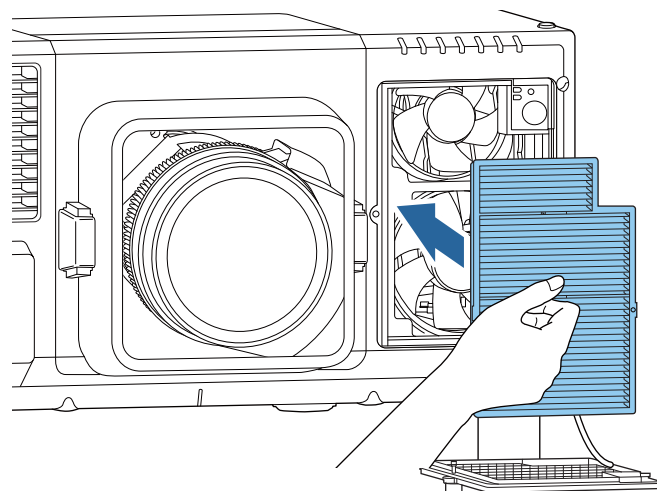

- 5** Close the air filter cover and tighten the fixing screw.

 Dispose of used air filters properly in accordance with your local regulations.
Material: Polypropylene

Color Calibration

Automatically adjusts aging deterioration of the color tone for the whole screen based on the default color settings.

Operating conditions for auto adjustment functions

The auto adjustment function for Color Calibration works under the following conditions:

- The screen surface is flat and not skewed or warped
- Using a matte white diffusion screen
- The projection size is 100 to 300 inches
- The projector is setup parallel to the projection surface



- Auto adjustment is not available when using the following lenses. ELPLX02, ELPLX02W, ELPLR04, ELPLL07, ELPLL08
- For some lenses, auto adjustment may not work even within the movement range when the amount of lens shift is too large.
 - ☛ "Adjusting the Position of the Projected Image (Lens Shift Adjustment)" [p.38](#)
- We recommend performing Color Calibration at least 30 minutes after turning on the projector or canceling the shutter function.
- To increase the accuracy of adjustments, we recommend darkening the room while projecting images and then making adjustments.
- Auto adjustment is performed using the camera built into the front of the projector. Do not block the camera or the projected images.
- Auto adjustment takes approximately one minute and 30 seconds.
- After making automatic adjustments, Color Uniformity and Color Matching are returned to their defaults.
- By using the scheduling function, you can automatically adjust the color for the whole screen at the time you set.
 - ☛ "Scheduling Function" [p.107](#)
- See the following if Color Calibration does not work correctly.
 - ☛ "Automatic adjustments are not performed correctly" [p.195](#)

- 1 Press the [Menu] button while projecting.
- 2 Select **Color Calibration** from **Extended**.
- 3 Select **Start Auto Adjustment**, and then press the [↵] button.

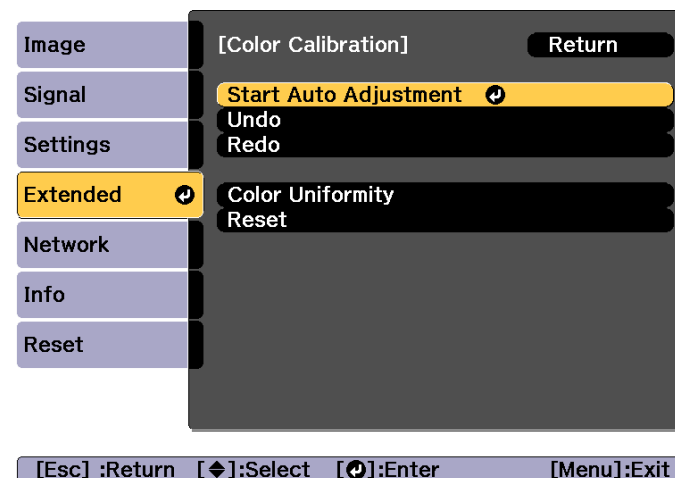

The adjustment pattern is displayed, and adjustment starts. If the projected image is displayed before the adjusting, the procedure is complete.



- See the following if an error occurs.
 - ☛ "Automatic adjustments are not performed correctly" [p.195](#)
- To return to the status before auto adjustment, select **Undo**. When you select **Redo** after selecting **Undo**, it returns the image to the status after auto adjustment.
- To return **Color Calibration** adjustment value to its default value, select **Reset**.

Color Uniformity

Adjusts the color tone for the whole screen.



The color tone may not be uniform even after performing color uniformity.

- 1 Press the [Menu] button while projecting.
- 2 Select **Display** from **Extended**.
- 3 Select **Color Uniformity**, and then press the [↵] button.
The following screen is displayed.

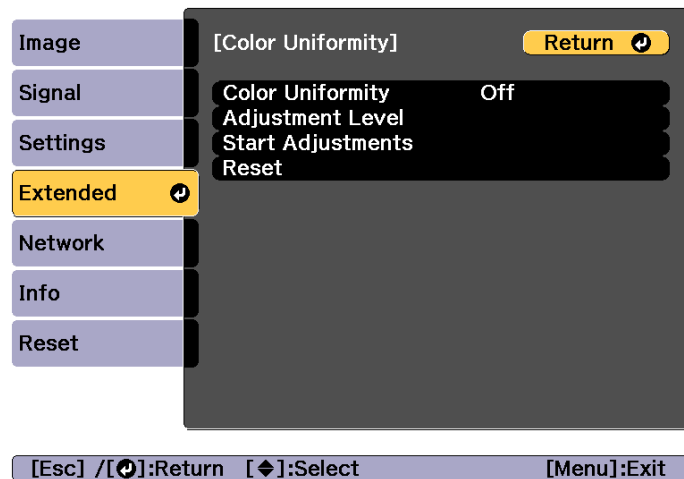

Color Uniformity: Turns color uniformity on or off.

Adjustment Level: There are eight levels from white, through gray, and up to black. You can adjust each level individually.

Start Adjustments: Starts adjusting color uniformity.

Reset: Resets all adjustments and settings for **Color Uniformity** to their default values.



The image may become distorted while adjusting **Color Uniformity**. The image is restored once adjustments are complete.

- 4 Select **Color Uniformity**, and then press the [↵] button.
- 5 Set to **On**, and then press the [Esc] button.
- 6 Select **Adjustment Level**, and then press the [↵] button.
- 7 Use the [◀][▶] buttons to set the adjustment level.
- 8 Press the [Esc] button to return to the previous screen.
- 9 Select **Start Adjustments**, and then press the [↵] button.
- 10 Select the area you want to adjust, and then press the [↵] button.
Adjust the outer areas first, and then adjust the whole screen.

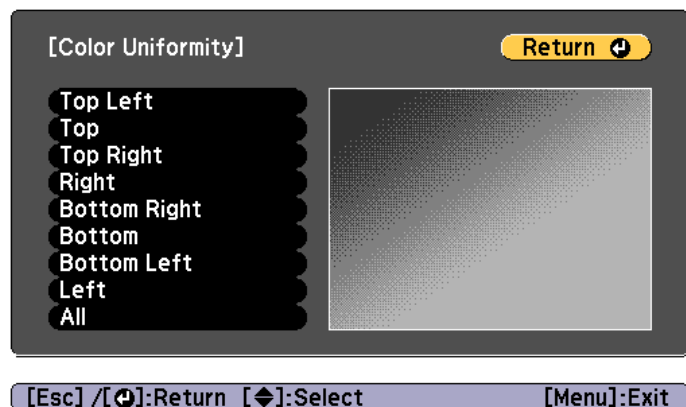

- 11** Use the [▲][▼] buttons to select the color you want to adjust, and then use the [◀][▶] buttons to adjust.

Press the [◀] button to weaken the color tone. Press the [▶] button to strengthen the color tone.

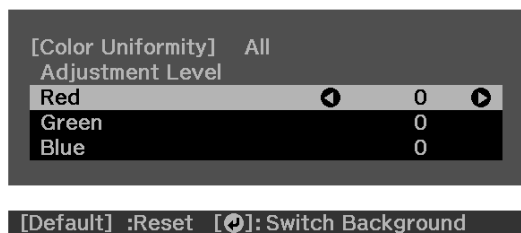

- 12** Return to step 6 and adjust each level.
- 13** To complete the adjustment, press the [Menu] button.



Appendix

About Epson Projector Management

Epson Projector Management lets you carry out operations such as checking the status of multiple Epson projectors that are connected to a network at a computer monitor, and controlling the projectors from the computer.

You can download Epson Projector Management from the following Web site.

<http://www.epson.com>

Changing Settings Using a Web Browser (Epson Web Control)

By using a Web browser of a computer or mobile device connected to the projector on a network, you can set functions and control the projector. This function allows you to perform setup and control operations remotely.

You can use the following Web browsers.

- Internet Explorer 11.0 or later (except for Metro) (Windows)
- Microsoft Edge (Windows)
- Safari (Mac)
- Chrome (Android)



If you set **Standby Mode** to **Communication On**, you can use the Web browser to make settings and perform control even if the projector is in standby mode (when the power is off).

☛ **Extended - Standby Mode** [p.143](#)

Displaying the Epson Web Control Screen

Use the following procedure to display the Epson Web Control screen.

Make sure your device and projector are ready for the network connection.



If your Web browser is set up to connect via a proxy server, the Epson Web Control screen cannot be displayed. To display Web Control, you need to make settings so that a proxy server is not used for a connection.

- 1** Connect your device to the same network as the connected projector.
The connection method varies depending on the device. See the manual supplied with your device for details. When using a tablet, check the Wi-Fi settings.
- 2** Start the Web browser on your device.
- 3** Connect by entering the address of the connected projector in the URL field of the Web browser.
The Home screen is displayed.

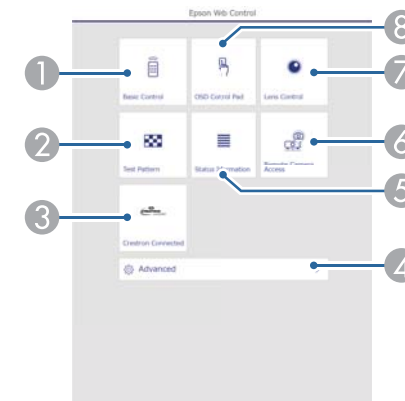

- 1 Basic Control**
☛ "Basic Control Screen" [p.215](#)
- 2 Test Pattern**
☛ "Test Pattern Operation Screen" [p.218](#)

3 Crestron Connected

☛ "About Crestron Connected@" [p.225](#)

4 Advanced

You are moved to the Advanced screen.

5 Status Information

☛ "Status Information Screen" [p.219](#)

6 Remote Camera Access

☛ "Remote Camera Access Screen" [p.219](#)

7 Lens Control

☛ "Lens Control Screen" [p.217](#)

8 OSD Control Pad

☛ "OSD Control Pad Screen" [p.216](#)



- When performing the functions from the Home screen, you may be prompted to enter the user name and password. When the login screen is displayed, enter your user name and password. (User name is **EPSONWEB**; default password is **admin**.)
- You cannot change the user name. You can change the password in the Network menu from the Configuration menu.
☛ **Network - Basic - Web Control Password** [p.150](#)
- You must enter the user name for Web Control Password even when the password is disabled.
- You can only set the following items from the **Advanced** screen.
Monitor Password (up to 16 single-byte alphanumeric characters)
☛ **Network - Basic - Monitor Password** [p.150](#)
IPv6 Settings (Manual)
☛ **Network - IPv6 Settings** [p.151](#), [p.155](#)
Add HTTP port (for the port number used for Web control, use anything except for 80 (default), 843, 3620, 3621, 3625, 3629, 4352, 4649, 5357, 10000, 10001, 41794)
☛ **Network - Others** [p.157](#)

Basic Control Screen

You can perform basic projector operations.

When the login screen is displayed, enter your user name and password. (The user name is **EPSONREMOTE**; the default password is **guest**.)

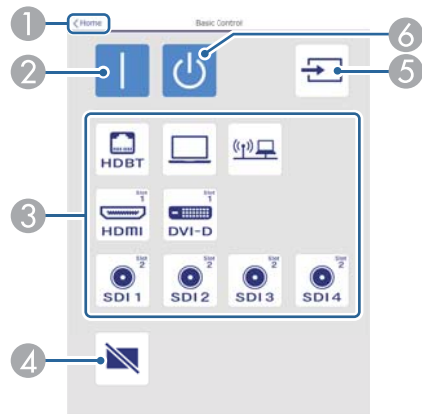

- ① Moves to the Home screen.
- ② Turns the projector on.
- ③ Switches to the target image.
- ④ Press to turn the image on or off temporarily.
- ⑤ Automatically detects the input signal.
- ⑥ Turns the projector off.

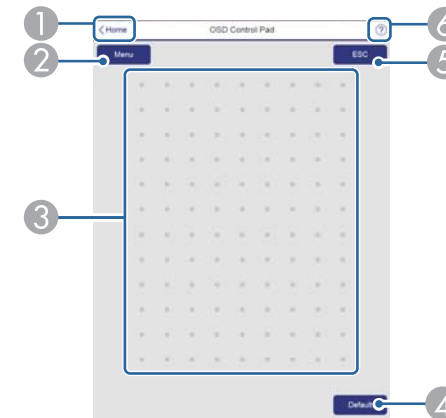

- ① Moves to the Home screen.
- ② Displays and closes the Configuration menu.
- ③ You can operate the Configuration menu using your finger or mouse. Flick to select an item, and tap to confirm the selection.
- ④ Enabled when **Default**: Reset is displayed on the Configuration menu guide. The settings being adjusted are returned to their default values.
- ⑤ Returns to the previous menu level in the Configuration menu.
- ⑥ Displays information on using the OSD Control Pad.

OSD Control Pad Screen

You can operate the Configuration menu of the projector.



Items in the Configuration menu that cannot be set in Epson Web Control are listed below.

- Image menu - Advanced - Gamma - Custom
- Signal menu - Advanced - EDID, DDC Buffer
- Settings Menu - User Button
- Extended menu - Display - Message Position
- Extended menu - Operation - Advanced - AC Voltage Monitoring, Lens Type
- Extended menu - Operation - Lens Calibration
- Extended Menu - Language
- Wireless LAN menu - Search Access Point

The settings for items on each menu are the same as the projector's Configuration menu.

☞ "Configuration Menu" [p.131](#)

Lens Control Screen

You can operate the lens of the projector.

Focus/Distortion Operation Screen

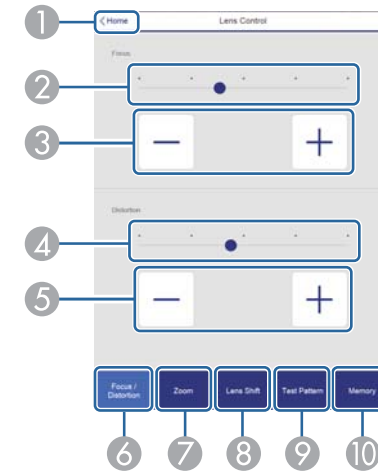

- 1 Moves to the Home screen.
- 2 Move the slider to adjust the focus.
- 3 Press the buttons to adjust the focus.
- 4 Move the slider to adjust image warping.*
- 5 Press the buttons to adjust image warping.*
- 6 Displays the Focus / Distortion operation screen.
- 7 Displays the Zoom operation screen.
- 8 Displays the Lens Shift operation screen.
- 9 Displays the Test Pattern operation screen.
- 10 Displays the Memory operation screen.

* This is not available for the ELPLU02.

Zoom Operation Screen

This is not available for the ELPLX02, ELPLX02W, or ELPLR04.

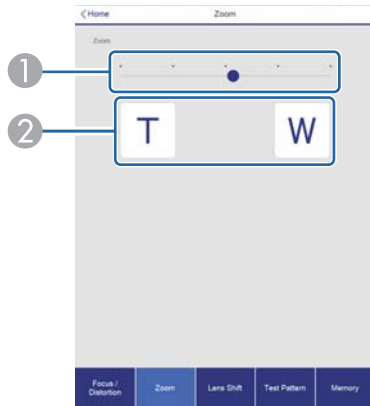

- ① Move the slider to adjust the zoom.
- ② Press the buttons to adjust the zoom.

Lens Shift Operation Screen

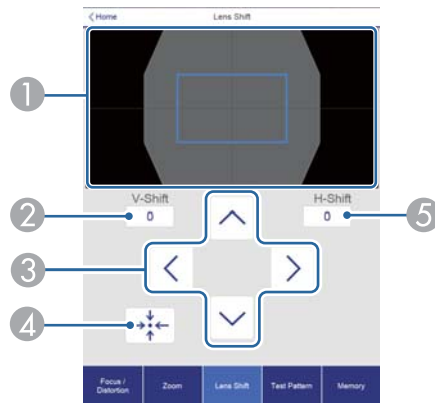

- ① Displays the position of the image as a blue square. When you move the image position, a red square is displayed at the destination.
- ② Displays the vertical image position. You can directly specify the position by tapping it and entering a number.
- ③ Moves the image position up, down, left, or right.

- ④ Moves the lens position to the home position if you press the **OK** button in the confirmation screen.
- ⑤ Displays the horizontal image position. You can directly specify the position by tapping it and entering a number.

Test Pattern Operation Screen

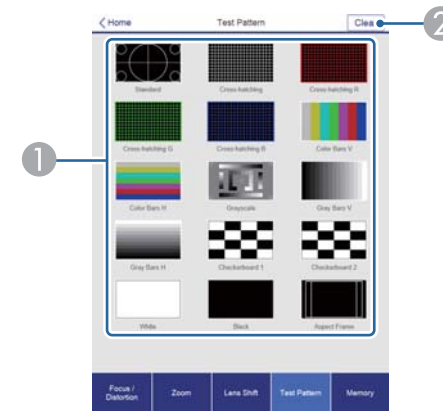

- ① Displays a test pattern.
- ② Closes the test pattern.

Memory Operation Screen

See the following for memory function details.

☞ "Memory Function" [p.105](#)



- ① Loads a memory.
- ② Saves a memory.
- ③ Displays a list of memories.
- ④ Erases a memory.
- ⑤ Changes a memory name.



- ① Moves to the Home screen.
- ② Displays the item name.
- ③ Displays the status of each item.
- ④ Selects a category from the following.
Status Information, Source, Signal Information, Network Wired, Network Wireless, Maintenance, Version, Air Temp Info, Voltage Warning Info

Status Information Screen

You can check the projector's status. See the following for display details.

☛ "Understanding the Status Information" [p.178](#)

Remote Camera Access Screen

You can take a picture of the projected image.

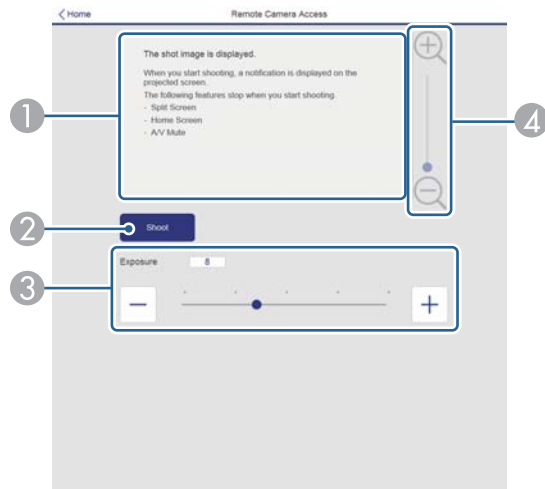

- ① Displays the image you shot.
- ② Press **Shoot** to take a picture of the projected image.
- ③ Adjusts the exposure when shooting.
- ④ Zooms in or zooms out of the image you shot.

Checking the projected image from a remote location

By shooting the projected image from a remote location, you can check it on the device you are using.

- Check that **Secure HTTP** is set to **On** from the **Network - Others** menu.
- This cannot be used when ELPLX02/ELPLX02W is attached.
- The remote camera access function is not available when using the following functions.
 - When using the built-in camera (Tiling, Tiling Assist, Screen Matching, Color Calibration)
 - Lens Calibration
 - Message Broadcasting features for the Epson Projector Management
- The following functions are canceled when using the remote camera access function.
 - Split Screen
 - Shutter
 - On-Screen Display (when the message is hidden)

1 On the **Password Protection** screen, set **Remote Camera Access** to **Off**.

☞ "Setting Password Protection" p.111

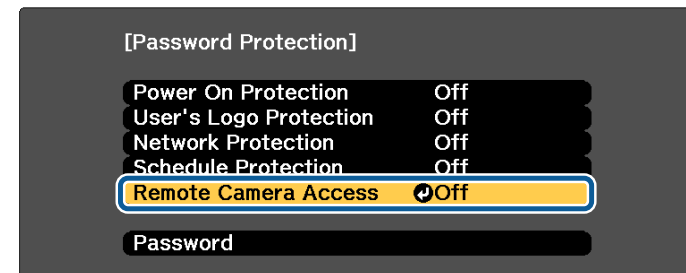

2 Select **Remote Camera Access** from **Network**.

- 3** Select **Password**, and then press the [↵] button.
 You can set up to 32 single-byte alphanumeric characters for the password (* : and spaces cannot be used).

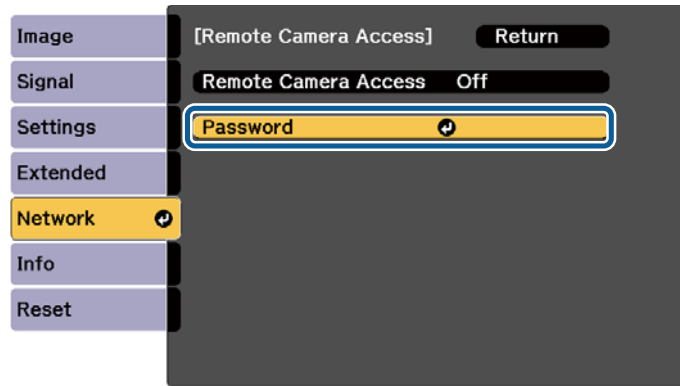

- 4** Set **Remote Camera Access** to **On**.

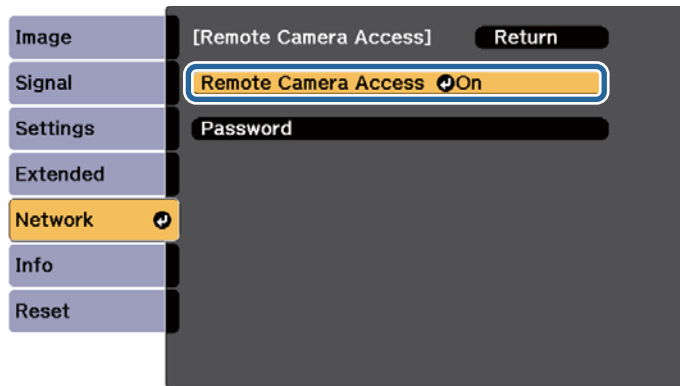

- 5** Launch the Web browser on the computer or mobile device connected to the network.
6 Enter the IP address of the projector in the address input box of the browser to connect to the Epson Web Control screen.

- 7** Select **Remote Camera Access**.
 When the login screen is displayed, enter your user name and password. (User name is **EPSONWEB**; default password is **admin**.)

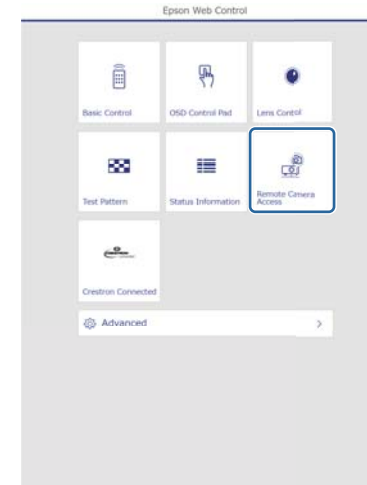

- 8** Press **Shoot**.



- 9** If the password screen is displayed, enter the password you set in step 3 for **Remote Camera Access - Password**, and then press **OK**.

A message is displayed on the projected image, and shooting starts. It takes approximately six seconds to acquire the image.



- Adjust the exposure as necessary. If you make any adjustments, shoot again and check the adjusted image.
- When shooting, you cannot perform any operations except for turning off the projector.
- You cannot shoot warning or caution messages.

Using the Mail Notification Function to Report Problems

When you set Mail Notification, notification messages are sent to the preset email addresses when a problem or warning occurs with a projector. This will enable the operator to be notified of problems with projectors even at locations away from the projectors.

 **Network - Notifications - Mail Notification** [p.155](#)



- Up to a maximum of three notification destinations (addresses) can be registered, and notification messages can be sent to all three destinations at once.
- If a projector develops a critical problem and suddenly stops working, it may not be able to send a message notifying an operator of the problem.
- If you set **Standby Mode** to **Communication On**, you can control the projector even if it is in standby mode (when the power is off).

 **Extended - Standby Mode** [p.143](#)

Reading error notification mail

When the Mail Notification function is set to On and a problem or warning occurs in the projector, the following email will be sent.

Sender: The email address set in **From**

Subject: EPSON Projector

Line 1: The projector name where the problem has occurred

Line 2: The IP address set for the projector where the problem has occurred.

Line 3 and on: Details of the problem

The details of the problem are listed line by line. The main message contents are listed below.

- Clean Air Filter (Air Filter Notice)
- Constant brightness expired (Constant Bright. End)
- Internal error (Internal Error)
- Fan related error (Fan Error)
- Sensor error (Sensor Error)
- Laser error (Laser Error)
- Laser warning (Laser Warning)
- Retardation Plate Error (Retardation Plate Error)
- Internal temperature error (High Temp Error/Overheating)
- High-speed cooling in progress (High Temp Warning)
- Low Air Flow (Low Air Flow)
- Low Air Flow Error (Filter Airflow Error)

- No-signal (No Signal)
No Signal is input to the projector. Check the connection status or check that the power for the signal source is turned on.
- Lens shift error (Lens shift error)
- No lens (No lens)
- Pump Error (Pump Error)
- Shutter Warning (Shutter Warning)
- Shutter Error (Shutter Error)
- Power Err. (Voltage) (Supply Voltage Error)

See the following to deal with problems or warnings.

☛ "Reading the Indicators" [p.171](#)

Management Using SNMP

By setting **SNMP** to **On** in the Configuration menu, notification messages are sent to the specified computer when a problem or warning occurs. This allows you to check for problems with projectors even at locations away from the projectors.

☛ **Network - Notifications - SNMP** [p.155](#)



- SNMP should be managed by a network administrator or someone who is familiar with the network.
- To use the SNMP function to monitor the projector, you need to install the SNMP manager program on your computer.
- The SNMP Agent for this projector complies with version 1 (SNMPv1).
- The managing function using SNMP cannot be used over wireless LAN in Quick connection mode.
- Up to two destination IP addresses can be saved.

ESC/VP21 Commands

You can control the projector from an external device using ESC/VP21.

Command list

When the power ON command is transmitted to the projector, the power turns on and it enters warm-up mode. When the projector's power has turned on, a colon ":" (3Ah) is returned.

When a command is input, the projector executes the command and returns a ":", and then accepts the next command.

If the command being processed terminates abnormally, an error message is output and a ":" is returned.

The main contents are listed below.

Item		Command	
Power ON/OFF	On	PWR ON	
	Off	PWR OFF	
Shutter function On/Off	On	MUTE ON	
	Off	MUTE OFF	
Signal selection	Computer	Auto	SOURCE 1F
		RGB	SOURCE 11
	Component	SOURCE 14	
	LAN	SOURCE 53	
	SDI Quad (Slot1)	SOURCE 100	
	SDI1 (Slot1)	SOURCE 160	
	SDI2 (Slot1)	SOURCE 110	
	SDI3 (Slot1)	SOURCE 120	
	SDI4 (Slot1)	SOURCE 140	
	SDI Quad (Slot2)	SOURCE 200	

Item	Command
SDI1 (Slot2)	SOURCE 260
SDI2 (Slot2)	SOURCE 210
SDI3 (Slot2)	SOURCE 220
SDI4 (Slot2)	SOURCE 240
HDMI(Slot1)	SOURCE 130
HDMI(Slot2)	SOURCE 230
DVI-D(Slot1)	SOURCE 1C0
DVI-D(Slot2)	SOURCE 2C0
HDBaseT	SOURCE 80
DisplayPort1(Slot1)	SOURCE 170
DisplayPort2(Slot1)	SOURCE 1D0
DisplayPort1(Slot2)	SOURCE 270
DisplayPort2(Slot2)	SOURCE 2D0

Add a Carriage Return (CR) code (0Dh) to the end of each command and transmit.

For more details, contact your local dealer or the nearest address provided in the Epson Projector Contact List.

 [Epson Projector Contact List](#)

Cable layouts

Serial connection

- Connector shape: D-Sub 9-pin (male)

- Projector input port name: RS-232C

<At the projector>

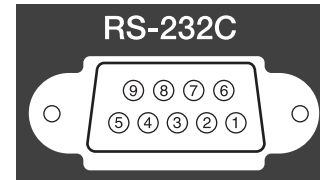

<At the computer>

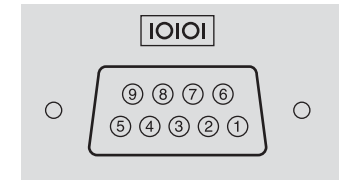

<At the projector>

GND 5
TD 3
RD 2

(PC serial cable)

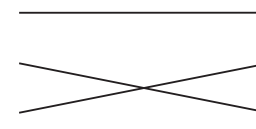

<At the computer>

5 GND
3 TD
2 RD

Signal Name	Function
GND	Signal wire ground
TD	Transmit data
RD	Receive data

Communications protocol

- Default baud rate setting: 9600 bps
- Data length: 8 bit
- Parity: None
- Stop-bit: 1 bit
- Flow control: None

About PJLink

PJLink was established by the JBMIA (Japan Business Machine and Information System Industries Association) as a standard protocol for controlling network-compatible projector's as part of their efforts to standardize projector control protocols.

The projector complies with the PJLink Class2 standard established by the JBMIA.

The port number used for the PJLink search function is 4352 (UDP).

You need to make network settings before you can use PJLink. See the following for more information on network settings.

☛ "Network Menu" p.148

It complies with all commands except for the following commands defined by PJLink Class2, and agreement was confirmed by the PJLink standard adaptability verification.

URL: <http://pjlink.jbmia.or.jp/english/>

• Non-compatible commands

	Function	PJLink Command
Mute settings	Image muting set	AVMT 11
	Audio muting set	AVMT 21

• Input ports and corresponding input source number

Input Port Name	Input Source Number
Computer	11
SLOT1-1*	21
SLOT1-2*	22
SLOT1-3*	23
SLOT1-4*	24

Input Port Name	Input Source Number
SLOT2-1*	25
SLOT2-2*	26
SLOT2-3*	27
SLOT2-4*	28
SDI Quad (Slot1)	35
SDI Quad (Slot2)	36
LAN	52
HDBaseT	56

* Indicates the port for the interface board connected to the slot. These are numbered 1 to 4 from the port on the left.

- Manufacturer name displayed for "Manufacture name information query"
EPSON
- Model name displayed for "Product name information query"
EPSON L12002Q/L12000Q

About Crestron Connected®

Crestron Connected® is an integrated control system provided by Crestron®. It can be used to monitor and control multiple devices connected on a network.

The projector supports the control protocol, and can therefore be used in a system built with Crestron Connected®.

Visit the Crestron® Web site for details on Crestron Connected®. (Only English-language displays are supported.)

<https://www.crestron.com/products/line/crestron-connected>

The following provides an overview of Crestron Connected®.

- **Remote operation using a Web browser**

You can operate a projector from your computer just like using a remote control.

- **Monitoring and control with application software**

You can use Crestron RoomView® Express/Crestron Fusion® provided by Crestron® to monitor devices in the system, to communicate with the help desk, and to send emergency messages.

This manual describes how to perform operations on your computer using a Web browser.



- You can only enter single-byte alphanumeric characters and symbols.
- The Message Broadcasting feature for Epson Projector Management is unavailable while using Crestron Connected®.
- If you set **Standby Mode** to **Communication On**, you can control the projector even if it is in standby mode (when the power is off).

☛ **Extended - Standby Mode** [p.143](#)

Operating a projector from your computer

Displaying the operation window

Check the following before carrying out any operations.

- Make sure the computer and projector are connected to the network.
- Set **Crestron Connected** to **On** from the **Network** menu.
☛ **Network - Others - Crestron Connected** [p.157](#)

1 Start the Web browser on the computer.

2 Enter the IP address of the projector in the address field of the Web browser, and press the Enter key on the keyboard.

The Epson Web Control home screen is displayed.

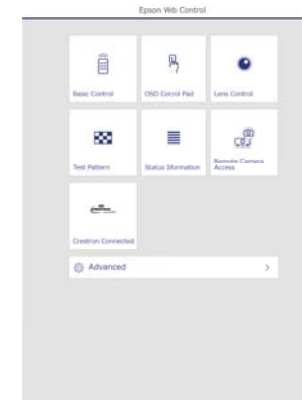

3 Press **Crestron Connected**.

The operation window is displayed.

Using the operation window

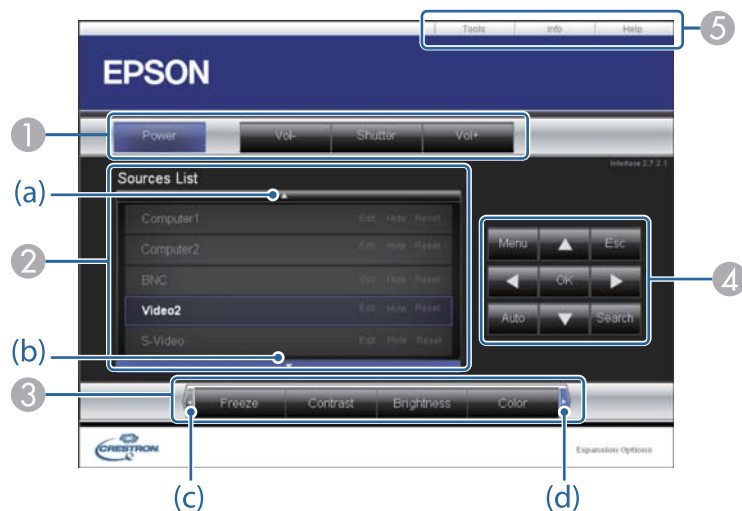

- ① You can perform the following operations when you click the buttons.

Button	Function
Power	Turns the projector power on or off.
Shutter	Press to turn the image on or off temporarily. ☛ "Hiding the Image Temporarily (Shutter)" p.102

- ② Switch to the image from the selected input source. To display input sources that are not shown in Source List, click (a) or (b) to scroll up or down. The current video signal input source is displayed in blue. You can change the source name if necessary.
- ③ You can perform the following operations when you click the buttons. To display buttons that are not shown in Source List, click (c) or (d) to scroll left or right.

Button	Function
Freeze	Images are paused or unpaused. ☛ "Freezing the Image (Freeze)" p.103
Contrast	Adjusts the difference between light and shade in the images.
Brightness	Adjusts the image brightness.
Color	Adjusts the color saturation for the images.
Sharpness	Adjusts the image sharpness.
Zoom	Click the [⊕] button to enlarge the image without changing the projection size. Click the [⊖] button to reduce the image that was enlarged with the [⊕] button.

- ④ The [▲] [▼] [◀] [▶] buttons perform the same operations as the [▲] [▼] [◀] [▶] buttons on the remote control. You can perform the following operations when you click the other buttons.

Button	Function
OK	Performs the same operation as the [↵] button on the remote control. ☛ "Remote Control" p.25
Menu	Displays and closes the Configuration menu.
Auto	If clicked while projecting analog RGB signals from the Computer In port, you can automatically optimize Tracking, Sync., and Position.
Search	Changes to the next input source that is sending an image. ☛ "Changing the Projected Image" p.62
Esc	Performs the same operation as the [Esc] button on the remote control. ☛ "Remote Control" p.25

5 You can perform the following operations when you click the tabs.

Tab	Function
Help	Displays the Help Desk window. Used to send messages to, and receive messages from, the administrator using Crestron Connected®.
Info	Displays information on the projector that is currently connected.
Tools	Changes settings in the projector that is currently connected. See the next section.

Using the tools window

The following window is displayed when you click the **Tools** tab on the operation window. You can use this window to change settings in the projector that is currently connected.

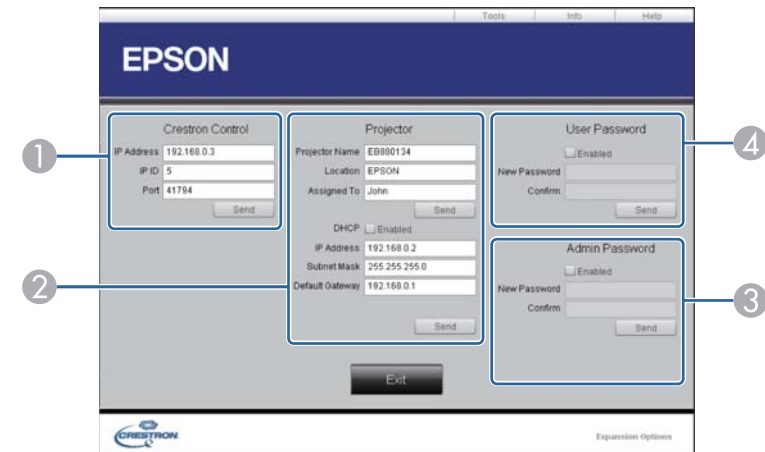

- 1 **Crestron Control**
Make settings for Crestron® central controllers.
- 2 **Projector**
The following items can be set.

Item	Function
Projector Name	Enter a name to differentiate the projector that is currently connected from other projectors on the network. (The name can contain up to 15 single-byte alphanumeric characters.)
Location	Enter an installation location name for the projector that is currently connected on the network. (The name can contain up to 32 single-byte alphanumeric characters and symbols.)
Assigned To	Enter a user name for the projector. (The name can contain up to 32 single-byte alphanumeric characters and symbols.)

Item	Function
DHCP	Select the Enabled check box to use DHCP. You cannot enter an IP address if DHCP is enabled.
IP Address	Enter the IP address to assign to the currently connected projector.
Subnet Mask	Enter a subnet mask for the currently connected projector.
Default Gateway	Enter the gateway address for the currently connected projector.
Send	Click this button to confirm the changes made to the Projector .

3 Admin Password

Select the **Enabled** check box to require a password to open the Tools window. The following items can be set.

Item	Function
New Password	Enter the new password when changing the password to open the Tools window. (The name can contain up to 26 single-byte alphanumeric characters.)
Confirm	Enter the same password as you entered in New Password . If the passwords are not the same, an error is displayed.
Send	Click this button to confirm the changes made to the Admin Password .

4 User Password

Select the **Enabled** check box to require a password to open the operation window on the computer. The following items can be set.

Item	Function
New Password	Enter the new password when changing the password to open the operation window. (The name can contain up to 26 single-byte alphanumeric characters.)
Confirm	Enter the same password as you entered in New Password . If the passwords are not the same, an error is displayed.
Send	Click this button to confirm the changes made to the User Password .

About Art-Net

Art-Net is an Ethernet communication protocol based on the TCP/IP protocol.

You can control the projector by using a DMX controller or an application system.

Channel definitions

The following explains the channel definitions used when controlling the projector in Art-Net.

First, set Channel 13 to "Can control".

Channel	Function	Operation		Parameters	Default	Operation Content
1	Adjusting light (Dimming)	0% - 100%		0 - 255	0	Sets the image brightness.
2	Shutter control	Shutter	Closed	0 - 63	128	Closes/opens the Shutter.
		Non-operational		64 - 191		
		Shutter	Open	192 - 255		
3	Switch source	Non-operational		0 - 23	0	Changes to the specified source.
		HDBaseT		24 - 31		
		Non-operational		32 - 55		
		Computer		56 - 63		
		Non-operational		64 - 79		
		LAN		80 - 87		
		Non-operational		88 - 127		
		SLOT1-1*		128 - 135		
		SLOT1-2*		136 - 143		
		SLOT1-3*		144 - 151		
		SLOT1-4*		152 - 159		
SLOT1-Quad*		160 - 167				



Channel	Function	Operation	Parameters	Default	Operation Content
		SLOT2-1*	168 - 175		
		SLOT2-2*	176 - 183		
		SLOT2-3*	184 - 191		
		SLOT2-4*	192 - 199		
		SLOT2-Quad*	200 - 207		
		Non-operational	208 - 255		

Channel	Function	Operation	Parameters	Default	Operation Content	
4	Lens position	Non-operational	0 - 31	0	Moves the lens shift to the home position.	
		Move to home position	32 - 63			
		Non-operational	64 - 255			
5	Horizontal lens shift	(+) lens adjustment	Movement - Large	0 - 31	128	Performs horizontal lens shift using the amount of movement specified.
			Movement - Medium	32 - 63		
			Movement - Small	64 - 95		
		Non-operational		96 - 159		
		(-) lens adjustment	Movement - Small	160 - 191		
			Movement - Medium	192 - 223		
			Movement - Large	224 - 255		
6	Vertical lens shift	(+) lens adjustment	Movement - Large	0 - 31	128	Performs vertical lens shift using the amount of movement specified.

Channel	Function	Operation		Parameters	Default	Operation Content
			Movement - Medium	32 - 63		
			Movement - Small	64 - 95		
		Non-operational		96 - 159		
		(-) lens adjustment	Movement - Small	160 - 191		
			Movement - Medium	192 - 223		
			Movement - Large	224 - 255		
7	Electronic zoom	(+) lens adjustment	Movement - Large	0 - 31	128	Performs electronic zoom using the amount of movement specified.
			Movement - Medium	32 - 63		
			Movement - Small	64 - 95		
		Non-operational		96 - 159		
		(-) lens adjustment	Movement - Small	160 - 191		
			Movement - Medium	192 - 223		
			Movement - Large	224 - 255		
8	Electronic focus	(+) lens adjustment	Movement - Large	0 - 31	128	Performs electronic focus using the amount of movement specified.
			Movement - Medium	32 - 63		
			Movement - Small	64 - 95		

Channel	Function	Operation	Parameters	Default	Operation Content		
		Non-operational	96 - 159				
		(-) lens adjustment	Movement - Small	160 - 191			
			Movement - Medium	192 - 223			
			Movement - Large	224 - 255			
9	Electronic distortion	(+) lens adjustment	Movement - Large	0 - 31	128	Performs electronic distortion using the amount of movement specified.	
			Movement - Medium	32 - 63			
			Movement - Small	64 - 95			
		Non-operational	96 - 159				
		(-) lens adjustment	Movement - Small	160 - 191			
			Movement - Medium	192 - 223			
			Movement - Large	224 - 255			
10	Load lens memory	Non-operational	0 - 15	0			Loads the specified lens memory.
		Load lens memory 1	16 - 31				
		Load lens memory 2	32 - 47				
		Load lens memory 3	48 - 63				
		Load lens memory 4	64 - 79				
		Load lens memory 5	80 - 95				
		Load lens memory 6	96 - 111				
		Load lens memory 7	112 - 127				

Channel	Function	Operation	Parameters	Default	Operation Content
		Load lens memory 8	128 - 143		
		Load lens memory 9	144 - 159		
		Load lens memory 10	160 - 175		
		Non-operational	176 - 255		
11	Power control	Power off	0 - 63	128	Turns the projector power on or off.
		Non-operational	64 - 191		
		Power on	192 - 255		
12	Geometry correction	Off	0 - 15	255	Performs geometry correction.
		H/V-Keystone	16 - 31		
		Quick Corner	32 - 47		
		Point Correction	48 - 63		
		Curved Surface	64 - 79		
		Corner Wall	80 - 95		
		Load geometry correction memory 1	96 - 111		Loads a geometry correction memory.
		Load geometry correction memory 2	112 - 127		
		Load geometry correction memory 3	128 - 143		
		Non-operational	144 - 175		
		Non-operational	176 - 255		
13	Lock	Cannot control	0 - 127	0	Enables/disables Art-Net operations.
		Can control	128 - 255		
14	Freeze	Non-operational	0 - 31	128	Images are paused or unpaused.
		Freeze off	32 - 95		
		Non-operational	96 - 159		
		Freeze on	160 - 223		
		Non-operational	224 - 255		

* Indicates the port for the interface board connected to the slot. These are numbered 1 to 4 from the port on the left.



While controlling the projector using Art-Net and performing operations from the remote control or control panel, settings made by the DMX controller or application software may not be applied to the projector correctly. If you want to apply control for multiple channels to the projector, set Channel 13 to "Cannot control" before you make any other settings, and then set Channel 13 to "Can control" after setting multiple channels. You can then control the projector without changing the setting for Channel 13.

The following optional accessories and consumables are available. Please purchase these products as and when needed. The following list of optional accessories and consumables is current as of: September 2019. Details of accessories are subject to change without notice and availability may vary depending on the country of purchase.

Optional Accessories

Lens unit

ELPLX02, ELPLX02W, ELPLU03, ELPLU03S, ELPLU04, ELPLW05, ELPLW06, ELPLW08, ELPLM10, ELPLM11, ELPLM15, ELPLL08

See the following for more information on the projection distance for each lens.

☛ "Screen Size and Projection Distance" [p.237](#)

Computer cable ELPKC02

(1.8 m - for mini D-Sub15-pin/mini D-Sub 15pin)

Computer cable ELPKC09

(3 m - for mini D-Sub15-pin/mini D-Sub 15pin)

Computer cable ELPKC10

(20 m - for mini D-Sub15-pin/mini D-Sub 15pin)

An extension cable for when the computer cable being used is too short.

Remote control cable set ELPKC28

(10 m 2 piece set)

Use this to guarantee operation from the remote control from a distance.

USB extension cable ELPKC31

If the USB cable is not long enough, connect this to the USB cable to extend it.

HDBaseT Transmitter ELPHD01

This transmitter performs long distance transmissions for HDMI signals and control signals for one LAN cable. Based on the HDBaseT standard. (HDCP 2.2 is not supported.)

Document Camera ELPDC13, ELPDC21

Use when projecting images such as books, OHP documents, or slides.

HDMI/DVI-D interface board*1 ELPIF01

SDI interface board*1 ELPIF02

DisplayPort interface board*1 ELPIF03

Install in the slot on the projector.

Low ceiling mount*2 ELPMB47

High ceiling mount*2 ELPMB48

Use when installing the projector on a ceiling. Do not use for any other purpose.

*1 Special techniques are required to install and remove the interface board, so make sure you contact a specialist.

*2 Special techniques are required to suspend the projector from a ceiling. Contact your local dealer or the nearest address provided in the Epson Projector Contact List. ☛ [Epson Projector Contact List](#)

Consumables

Air filters ELPAF58

Use as a replacement for used air filters.

Lens Type and Projection Range

The available projection range varies depending on the lens being used.
The following shows the projection range when the aspect ratio is 16:9.

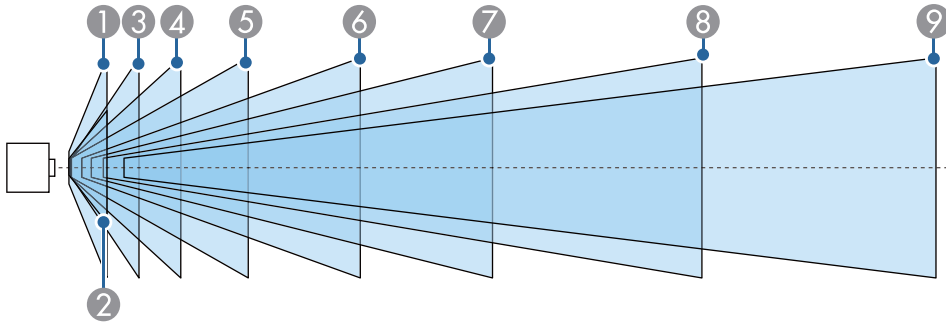

Lens Model Number	Screen Size (inch.)	Projection Distance (cm)
①	ELPLX02 ELPLX02W	100 - 1000
	ELPLR04	60 - 1000
②	ELPLU03 ELPLU03S	80 - 500
	ELPLW05	80 - 500
③	ELPLU02 ELPLU04	60 - 1000
	ELPLW08	60 - 1000
⑤	ELPLW04 ELPLW06	60 - 1000
	ELPLM15 ELPLM09 ELPLS04	60 - 1000
⑦	ELPLM06 ELPLM10	60 - 1000

Lens Model Number	Screen Size (inch.)	Projection Distance (cm)
⑧	ELPLM07 ELPLM11	60 - 1000
	⑨	ELPLL07 ELPLL08

If the screen is larger than 500 inches, fine text and images may not be displayed clearly.

Projection Distance

You can calculate the projection distance by applying the numbers in the tables to the following formulas.

The units used in the formulas and the tables are all in centimeters (cm).

- Minimum projection distance = Screen width x Projection distance ratio (Wide)
- Maximum projection distance = Screen width x Projection distance ratio (Tele)



There are also tools available that can perform detailed projection simulations.

<https://epson.com/>

Projection distance ratio by lens

Lens Model Number	Projection distance ratio (Wide/Tele)		
	16:10	16:9	4:3
ELPLX02 ELPLX02W	0.37	0.34	0.45



Lens Model Number	Projection distance ratio (Wide/Tele)		
	16:10	16:9	4:3
ELPLU03 ELPLU03S	0.51/0.62	0.46/0.56	0.61/0.74
ELPLU02 ELPLU04	0.68/0.83	0.62/0.75	0.82/1.00
ELPLW05	0.82/1.15	0.74/1.04	0.99/1.38
ELPLW08	0.93/1.30	0.83/1.17	1.11/1.56
ELPLW04 ELPLW06	1.27/1.74	1.15/1.57	1.53/2.09
ELPLM15 ELPLM09 ELPLS04	1.69/2.75	1.52/2.47	2.03/3.30
ELPLM06 ELPLM10	2.61/3.99	2.34/3.59	3.13/4.78
ELPLM07 ELPLM11	3.80/5.81	3.42/5.23	4.56/6.97
ELPLL07 ELPLL08	5.66/7.96	5.09/7.16	6.79/9.55
ELPLR04	0.75	0.67	0.90

Inch.	Width x Height		
	16:10	16:9	4:3
150	323 x 202	332 x 187	305 x 229
200	431 x 269	443 x 249	406 x 305
300	646 x 404	664 x 374	610 x 457
350	754 x 471	775 x 436	711 x 533
400	862 x 538	886 x 498	813 x 610
450	969 x 606	996 x 560	914 x 686
500	1077 x 673	1107 x 623	1016 x 762
550	1185 x 740	1218 x 685	1118 x 838
600	1292 x 808	1328 x 747	1219 x 914
650	1400 x 875	1439 x 809	1321 x 991
700	1508 x 942	1550 x 872	1422 x 1067
750	1615 x 1010	1660 x 934	1524 x 1143
800	1723 x 1077	1771 x 996	1626 x 1219
850	1831 x 1144	1882 x 1058	-
900	1939 x 1212	1992 x 1121	-
950	-	2103 x 1183	-
1000	-	2214 x 1245	-

Screen Size

Inch.	Width x Height		
	16:10	16:9	4:3
60	129 x 81	133 x 75	122 x 91
80	172 x 108	177 x 100	163 x 122
100	215 x 135	221 x 125	203 x 152
120	258 x 162	266 x 149	244 x 183

H/V-Keystone

☛ "H/V-Keystone" p.66

Lens type	Vertical	Horizontal
ELPLM15/ELPLM11/ ELPLM10/ELPLM09/ ELPLM07/ELPLM06/ ELPLS04/ELPLL08/ ELPLL07	-45° to 45°	-30° to 30°
ELPLX02/ELPLX02W	-17° to 17°	-17° to 17°
ELPLU03/ELPLU03S	-35° to 35°	-30° to 30°
ELPLU04/ELPLU02	-32° to 32°	-30° to 30°
ELPLR04	-31° to 31°	-30° to 30°
ELPLW06/ELPLW05/ ELPLW04	-40° to 40°	-30° to 30°
ELPLW08	-36° to 36°	-30° to 30°

Curved Surface

☛ "Curved Surface" p.68

The values in the table are the minimum values for R/L in the illustration.
(Approximate value when projecting at maximum zoom. ELPLR04 does not support lens shift.)

Horizontally curved surface (concave)

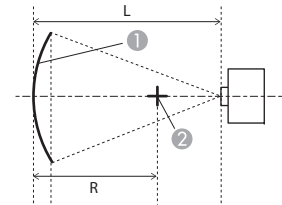

- ① Screen
- ② Center of the circle of which the curved surface is an arc
- L Projection distance
- R Radius of the circle of which the curved surface is an arc

Top view

Lens type	Vertical lens shift: Home position	Vertical lens shift: Top
	Side view	Side view
ELPLM15/ELPLM09/ ELPLS04	0.27	0.28
ELPLX02/ELPLX02W	2.45*	2.65
ELPLU03/ELPLU03S	1.00	1.01
ELPLU04/ELPLU02	0.46	0.49
ELPLR04	0.44*	-
ELPLW05	0.41	0.41
ELPLW06/ELPLW04	0.33	0.34
ELPLW08	0.39	0.40
ELPLM10/ELPLM06	0.20	0.20
ELPLM11/ELPLM07	0.14	0.14

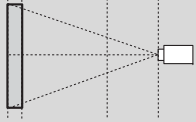
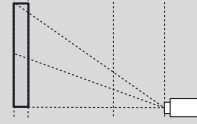
Lens type	Vertical lens shift: Home position	Vertical lens shift: Top
	 Side view	 Side view
ELPLL08/ELPLL07	0.10	0.10

*Cannot be corrected accurately. Move the lens position to the bottom.

Horizontally curved surface (convex)

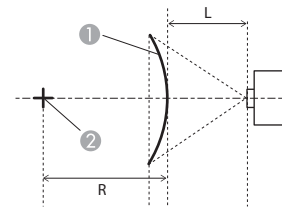

- ① Screen
- ② Center of the circle of which the curved surface is an arc
- L Projection distance
- R Radius of the circle of which the curved surface is an arc

Top view

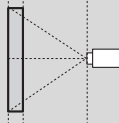
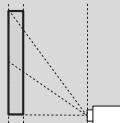
Lens type	Vertical lens shift: Home position	Vertical lens shift: Top
	 Side view	 Side view
ELPLM15/ELPLM09/ ELPLS04	0.53	0.55
ELPLX02/ELPLX02W	8.44*	8.44
ELPLU03/ELPLU03S	3.52	3.52
ELPLU04/ELPLU02	2.33	2.45
ELPLR04	1.98*	-
ELPLW05	1.69	1.69
ELPLW06/ELPLW04	0.81	0.85
ELPLW08	1.37	1.44
ELPLM10/ELPLM06	0.30	0.31
ELPLM11/ELPLM07	0.19	0.19

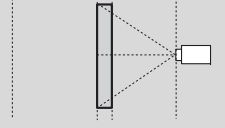
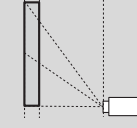
Lens type	Vertical lens shift: Home position	Vertical lens shift: Top
	 Side view	 Side view
ELPLL08/ELPLL07	0.13	0.13

*Cannot be corrected accurately. Move the lens position to the bottom.

Vertically curved surface (concave)

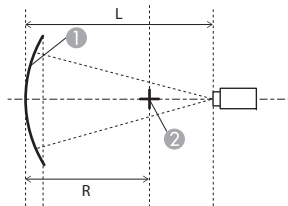

- ① Screen
 - ② Center of the circle of which the curved surface is an arc
- L Projection distance
R Radius of the circle of which the curved surface is an arc

Side view

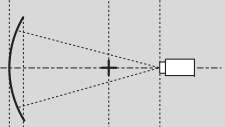
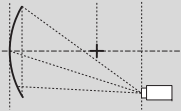
Lens type	Vertical lens shift: Home position	Vertical lens shift: Top
	 Side view	 Side view
ELPLM15/ELPLM09/ ELPLS04	0.18	0.21
ELPLX02/ELPLX02W	1.57*	2.69

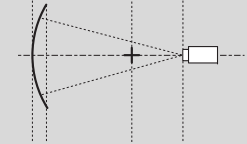
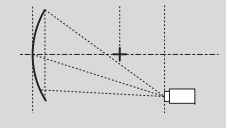
Lens type	Vertical lens shift: Home position	Vertical lens shift: Top
	 Side view	 Side view
ELPLU03/ELPLU03S	0.48	0.45
ELPLU04/ELPLU02	0.36	0.65
ELPLR04	0.34*	-
ELPLW05	0.32	0.32
ELPLW06/ELPLW04	0.23	0.27
ELPLW08	0.30	0.41
ELPLM10/ELPLM06	0.13	0.15
ELPLM11/ELPLM07	0.11	0.11
ELPLL08/ELPLL07	0.08	0.08

*Cannot be corrected accurately. Move the lens position to the bottom.

Vertically curved surface (convex)

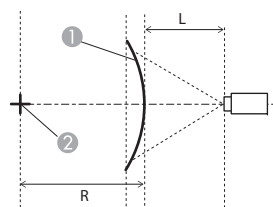

- ① Screen
- ② Center of the circle of which the curved surface is an arc
- L Projection distance
- R Radius of the circle of which the curved surface is an arc

Side view

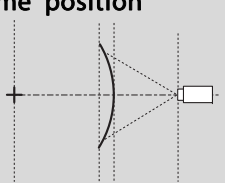
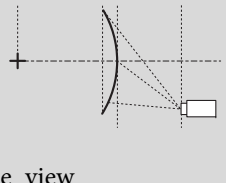
Lens type	Vertical lens shift: Home position	Vertical lens shift: Top
		
	Side view	Side view
ELPLM15/ELPLM09/ ELPLS04	0.25	0.29
ELPLX02/ELPLX02W	3.20*	3.40
ELPLU03/ELPLU03S	1.62	1.65
ELPLU04/ELPLU02	0.97	1.12
ELPLR04	0.83*	-
ELPLW05	0.72	0.73
ELPLW06/ELPLW04	0.37	0.43
ELPLW08	0.61	0.69
ELPLM10/ELPLM06	0.15	0.17
ELPLM11/ELPLM07	0.10	0.11

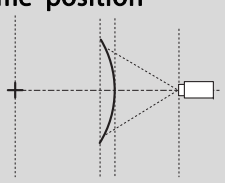
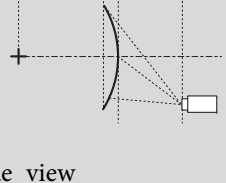
Lens type	Vertical lens shift: Home position	Vertical lens shift: Top
		
	Side view	Side view
ELPLL08/ELPLL07	0.07	0.08

*Cannot be corrected accurately. Move the lens position to the bottom.

Corner Wall

☛ "Corner Wall" p.71

The α in the figure is the maximum angle in which the projector can move. See the table below for detailed values. (Approximate value when projecting at maximum zoom. ELPLR04 does not support lens shift.)

Concave horizontal corner correction (correction to bilateral symmetry by using corners as the center line)

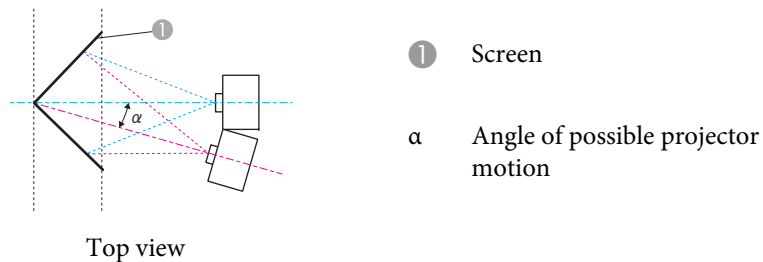

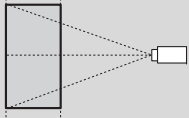
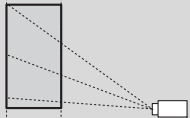
Lens type	Vertical lens shift: Home position  Side view	Vertical lens shift: Top  Side view
ELPLM15/ELPLM09/ ELPLS04	31°	27°
ELPLX02/ELPLX02W	9°*	-
ELPLU03/ELPLU03S	23°	22°
ELPLU04/ELPLU02	28°	14°
ELPLR04	30°*	-
ELPLW05	31°	27°
ELPLW06/ELPLW04	32°	23°

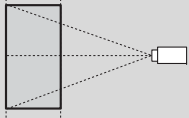
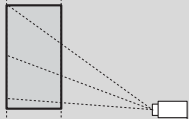
Lens type	Vertical lens shift: Home position  Side view	Vertical lens shift: Top  Side view
ELPLW08	32°	19°
ELPLM10/ELPLM06	30°	30°
ELPLM11/ELPLM07/ ELPLL08/ELPLL07	29°	29°

*Cannot be corrected accurately. Move the lens position to the bottom.

Convex horizontal corner correction (correction to bilateral symmetry by using corners as the center line)

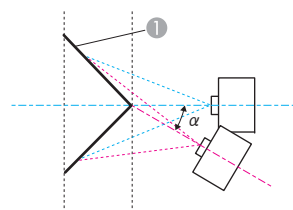

Top view

① Screen

α Angle of possible projector motion

Concave vertical corner correction (correction to horizontal symmetry by using corners as the center line)

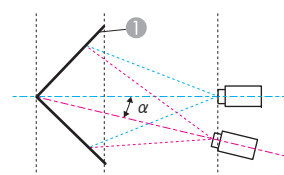

Side view

① Screen

α Angle of possible projector motion

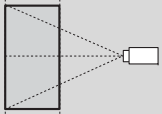
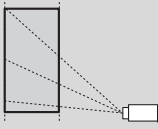
Lens type	Vertical lens shift: Home position  Side view	Vertical lens shift: Top  Side view
ELPLM15/ELPLM09/ ELPLS04	15°	14°
ELPLX02/ELPLX02W/ ELPLU04/ELPLU03/ ELPLU03S/ELPLU02	-	-
ELPLR04	0°	-
ELPLW05	2°	2°
ELPLW06/ELPLW04	11°	10°
ELPLW08	5°	4°
ELPLM10/ELPLM06	19°	19°
ELPLM11/ELPLM07	21°	21°
ELPLL08/ELPLL07	23°	23°

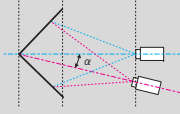
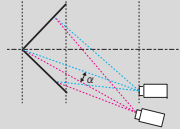
Lens type	Vertical lens shift: Home position  Side view	Vertical lens shift: Top  Side view
ELPLM15/ELPLM09/ ELPLS04	27°	14°
ELPLX02/ELPLX02W	-	-
ELPLU03/ELPLU03S	33°	21°
ELPLU04/ELPLU02	32°	5°
ELPLR04	32°*	-
ELPLW05	32°	24°
ELPLW06/ELPLW04	30°	14°
ELPLW08	31°	10°
ELPLM10/ELPLM06	23°	15°
ELPLM11/ELPLM07	22°	16°
ELPLL08/ELPLL07	21°	17°

*Cannot be corrected accurately. Move the lens position to the bottom.

Convex vertical corner correction (correction to horizontal symmetry by using corners as the center line)

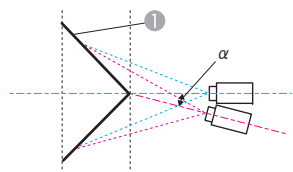

① Screen

α Angle of possible projector motion

Side view

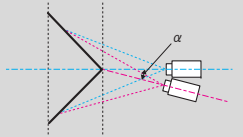
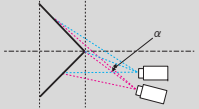
Lens type	Vertical lens shift: Home position  Side view	Vertical lens shift: Top  Side view
ELPLM15/ELPLM09/ ELPLS04	20°	9°
ELPLX02/ELPLX02W	-	-
ELPLU03/ELPLU03S	4°	-
ELPLU04/ELPLU02	10°	-
ELPLR04	12°*	-
ELPLW05	13°	7°
ELPLW06/ELPLW04	18°	4°
ELPLW08	14°	-
ELPLM10/ELPLM06	20°	12°
ELPLM11/ELPLM07	20°	14°
ELPLL08/ELPLL07	20°	16°

*Cannot be corrected accurately. Move the lens position to the bottom.

Supported Resolutions



See the *Specifications* for more details on supported signals. You can download the information from the following Web site.

<http://epson.sn>

Computer signals (analog RGB)

Signal	Refresh Rate (Hz)	Resolution (Dots)
VGA	60/72/75/85	640x480
SVGA	60/72/75/85	800x600
XGA	60/70/75/85	1024x768
WXGA	60	1280x768
	60/75/85	1280x800
	60	1366x768
WXGA+	60/75/85	1440x900
WXGA++	60	1600x900
SXGA	70/75/85	1152x864
	60/75/85	1280x960
	60/75/85	1280x1024
SXGA+	60/75	1400x1050
WSXGA+*1	60	1680x1050
UXGA	60	1600x1200
1920x1080	50/60	1920x1080
WUXGA*2	60	1920x1200
SDTV (480p)	59.94	720x480
SDTV (576p)	50	720x576
HDTV (720p)	50/59.94/60	1280x720

Signal	Refresh Rate (Hz)	Resolution (Dots)
HDTV (1080p)	50/59.94/60	1920x1080

*1 Only compatible when **Wide** is selected as the **Resolution** from the Configuration menu.

*2 Only compatible when VESA CVT-RB (Reduced Blanking) signal is input.

Even when signals other than those mentioned above are input, it is likely that the image can be projected. However, not all functions may be supported.

Component Video

Signal	Refresh Rate (Hz)	Resolution (Dots)
SDTV (480i/480p)	59.94	720x480
SDTV (576i/576p)	50	720x576
HDTV (720p)	50/59.94/60	1280x720
HDTV (1080i)	50/59.94/60	1920x1080

Input signals from the DVI-D In port, HDMI In port, HDBaseT port, and DisplayPort In port

Signal	Refresh Rate (Hz)	Resolution (Dots)
VGA	60	640x480
SVGA	60	800x600
XGA	60	1024x768
WXGA	60	1280x800
	60	1366x768
WXGA+	60	1440x900
WXGA++	60	1600x900
WSXGA+	60	1680x1050
SXGA	60	1280x960



Signal	Refresh Rate (Hz)	Resolution (Dots)
	60	1280x1024
SXGA+	60	1400x1050
UXGA	60	1600x1200
1920x1080	50/60	1920x1080
WUXGA*1	60	1920x1200
QXGA*2	60	2048x1536
WQHD*2	60	2560x1440
WQXGA*1*2	60	2560x1600
SDTV (480i/480p)	59.94	720x480
SDTV (576i/576p)	50	720x576
HDTV (720p)	50/59.94/60	1280x720
HDTV (1080i)	50/59.94/60	1920x1080
HDTV (1080p)*3	23.98/24/29.97/30/50/59.94/60	1920x1080
4Kx2K*2*3	23.98/24/25/29.97/30	3840x2160
4Kx2K*2*4	50/59.94/60	3840x2160
4Kx2K (SMPTE)*2*3	23.98/24	4096x2160
4Kx2K (SMPTE)*5	25/29.97/30	4096x2160
4Kx2K (SMPTE)*2*4	50/59.94/60	4096x2160
4K (3840x2160) Dual*6	100.00/120.00	3840x2160

Signal	Refresh Rate (Hz)	Resolution (Dots)
4K (3840x2160) Dual Columns*6	100.00/120.00	3840x2160

*1 Only compatible when VESA CVT-RB (Reduced Blanking) signal is input.

*2 Only for HDMI, HDBaseT, and DisplayPort input.

*3 HDMI and HDBaseT input only support HDR (HDR10 and HLG).

*4 HDMI input only supports HDR (HDR10 and HLG).

*5 Only for HDMI and DisplayPort input.

*6 Only for DisplayPort input. This is only supported when **Link Type** is set to **Dual (3840x2160)** or **Dual (1920x2160 Split Screen)** in **DisplayPort Settings** from the Configuration menu.

Input signals from SDI In port

Mode	Signal	Refresh Rate (Hz)	Resolution (Dots)	Color difference signals	Number of Bits	Level
SD-SDI	NTSC Interlace	59.94	720x480	YCbCr 4:2:2	10 bits	-
	PAL Interlace	50	720x576			
HD-SDI	Progressive	50/59.94/60	1280x720	YCbCr 4:2:2	10 bits	-
	Interlace	50/59.94/60	1920x1080			
	Progressive	23.98/24/25/29.97/30	1920x1080			
3G-SDI SMPTE: ST425-1	Interlace	50/59.94/60	1920x1080	RGB YCbCr 4:4:4	10/12 bits	A/B-DL
	Progressive*1	23.98/24/25/29.97/30	1920x1080			
	Progressive*1	50/59.94/60	1920x1080	YCbCr 4:2:2	10 bits	B-DS
	Interlace	50/59.94/60	1920x1080			
	Progressive*1	23.98/24/25/29.97/30/50/59.94/60	1920x1080			
3G-SDI SMPTE: ST425-5*1*4	Progressive	23.98/24/25/29.97/30	3840x2160	RGB YCbCr 4:2:2/4:4:4:4	10/12 bits*2	A
		50/59.94/60	3840x2160	YCbCr 4:2:2	10 bits	
		23.98/24/25/29.97/30	4096x2160	RGB YCbCr 4:2:2/4:4:4:4	10/12 bits*2	

Mode	Signal	Refresh Rate (Hz)	Resolution (Dots)	Color difference signals	Number of Bits	Level
		50/59.94/60	4096x2160	YCbCr 4:2:2	10 bits	
12G-SDI SMPTE: ST2082-10*1*3	Progressive	23.98/24/25/29.97/30	3840x2160	RGB YCbCr 4:2:2/4:4:4:4	10/12 bits*2	Type1
		50/59.94/60	3840x2160	YCbCr 4:2:2	10 bits	
		23.98/24/25/29.97/30	4096x2160	RGB YCbCr 4:2:2/4:4:4:4	10/12 bits*2	
		50/59.94/60	4096x2160	YCbCr 4:2:2	10 bits	

*1 Supports HDR (HDR10 and HLG).

*2 YCbCr 4:2:2 only supports 12 bits.

*3 Only supports the SDI1 In port.

*4 Only supports quad-link input.

Projector General Specifications

Product name		EB-L12002Q	EB-L12000Q
Dimensions		620 (W) x 280 (H) x 720 (D) mm (not including raised section)	
LCD panel size		1.04"	
Display method		Polysilicon TFT active matrix	
Resolution		8,294,400 4K (width 3840 x height 2160 dots) x3	
Focus adjustment		Automatic	
Zoom adjustment		Automatic	
Lens Shift		Automatic (Maximum vertical direction of approx. 58%, Maximum horizontal direction of approx. 16%*1)	
Light source		Laser diode	
Light source output power		Maximum 40.6 W x 10.5 (426.3 W)	
Wavelength		450-460 nm	
Light source life expectancy*2		Approximately 20,000 hours (Light Source Mode: Normal, Quiet) Approximately 43,000 hours (Light Source Mode: Extended)	
Power		100-120V AC±10% 50/60Hz 10.9A 200-240V AC±10% 50/60Hz 9.0A	
Power consumption	100 - 120 V	Rated power consumption: 1,083 W Standby power consumption (Communication On): 2.0 W Standby power consumption (Communication Off): 0.5 W	
	200 - 240V	Rated power consumption: 1,741 W Standby power consumption (Communication On): 2.0 W Standby power consumption (Communication Off): 0.5 W	
Operating altitude		Altitude 0 to 3,048 m	
Operating Temperature		0 to +50°C*3 (Altitude of 0 to 1,500 m, no condensation) 0 to +45°C*3 (Altitude of 1,501 to 3,048 m, no condensation)	
Storage temperature		-10 to +60°C (No condensation)	

Mass	Approx. 52kg	Approx. 52kg
-------------	--------------	--------------

*1 ELPLU03/ELPLU03S/ELPLW05 has a maximum vertical direction of approx. 18% and a maximum horizontal direction of approx. 6%; ELPLX02/ELPLX02W has a maximum upward direction of approx. 18%, a maximum downward direction of approx. 5%, and a maximum horizontal direction of approx. 10%. Lens shift is not available for the ELPLR04.

*2 Approximate time until light source brightness is reduced by half.

(Assuming the projector is used in an atmosphere in which airborne particulate matter is less than 0.04 to 0.2mg/m³. The estimated time varies depending on the projector usage and operating conditions.)

*3 If the surrounding temperature gets too high, the brightness of the light source dims gradually.

(Approximately 40°C at an altitude of 0 to 1,500 m, and approximately 35°C at an altitude of 1,501 to 3,048 m; however, this may vary depending on the surroundings and so on.)

If the maximum operating temperature is exceeded, the projector may turn off automatically.

You may hear the fan operating during use in a low-temperature environment, but this is not a malfunction.

Connectors (Projector)	Computer In port	1	Mini D-Sub15-pin (female) blue
	Computer Out port	1	Mini D-Sub15-pin (female) black
	LAN port	1	RJ-45
	HDBaseT port	1	RJ-45 HDCP2.2 supported
	RS-232C port	1	Mini D-Sub 9-pin (male)
	Service port*	1	USB connector (Type B) USB 2.0 supported
	USB-A port*	1	USB connector (Type A) (up to 900 mA) USB 2.0 supported
	Remote port	1	Stereo mini jack (3.5Φ)
	Slot	2	Dedicated port for interface board
Connectors (HDMI/DVI-D interface board)	HDMI In port	1	HDMI HDCP2.2 supported
	DVI-D In port	1	DVI-D 24pin Single link HDCP compatible
	DC Out port (Power only)*	1	USB connector (Type A) (up to 500 mA)
Connectors (SDI interface board)	SDI In port	4	BNC (female)
	SDI Out port	4	BNC (female)

* USB ports are not guaranteed to operate all devices that support USB.



This product is also designed for IT power distribution system with phase-to-phase voltage 230V.

Supplier's DECLARATION of CONFORMITY

According to 47CFR, Part 2 and 15

Class A digital devices, peripherals & switching power supplies

We: Epson America, Inc.
Located at: 3840 Kilroy Airport Way
Long Beach, CA 90806
Tel: 562-981-3840

Declare under sole responsibility that the product identified herein, complies with 47CFR Part 2 and 15 of the FCC rules as a Class A digital device. Each product marketed, is identical to the representative unit tested and found to be compliant with the standards. Records maintained continue to reflect the equipment being produced can be expected to be within the variation accepted, due to quantity production and testing on a statistical basis as required by 47CFR §2.906. Operation is subject to the following two conditions : (1) this device may not cause harmful interference, and (2) this device must accept any interference received, including interference that may cause undesired operation.

Trade Name: EPSON
Type of Product: LCD Projector
Model: H832A/H832C
Options: Product Name: Remote Controller
Model: 2185360xx (x=0-9)

FCC Compliance Statement For United States Users

This equipment has been tested and found to comply with the limits for a Class A digital device, pursuant to part 15 of the FCC Rules. These limits are designed to provide reasonable protection against harmful interference when the equipment is operated in a commercial environment. This equipment generates, uses, and can radiate radio frequency energy and, if not installed and used in accordance with the instruction manual, may cause harmful interference to radio communications. Operation of this equipment in a residential area is likely to cause harmful interference in which case the user will be required to correct the interference at his own expense.

This device complies with part 15 of the FCC rules. Operation is subject to the following two conditions : (1) this device may not cause harmful interference, and (2) this device must accept any interference received, including interference that may cause undesired operation.

WARNING

The connection of a non-shielded equipment interface cable to this equipment will invalidate the FCC Certification or Declaration of this device and may cause interference levels which exceed the limits established by the FCC for this equipment. It is the responsibility of the user to obtain and use a shielded equipment interface cable with this device. If this equipment has more than one interface connector, do not leave cables connected to unused interfaces. Changes or modifications not expressly approved by the manufacturer could void the user's authority to operate the equipment.

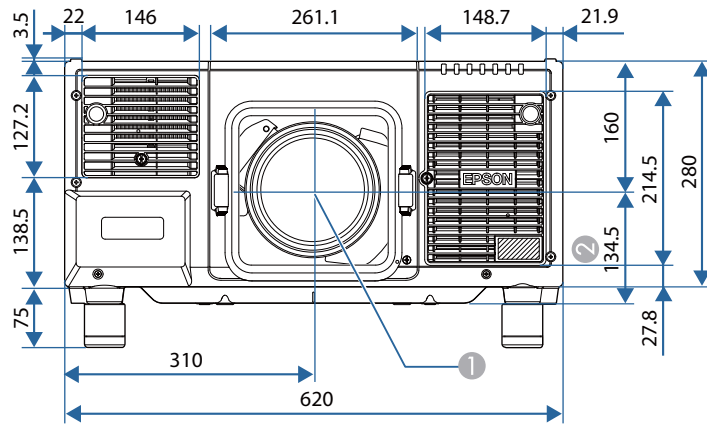

- ① Center of lens
- ② Distance from center of lens to Ceiling mount fixing point (ELPMB47/ELPMB48)

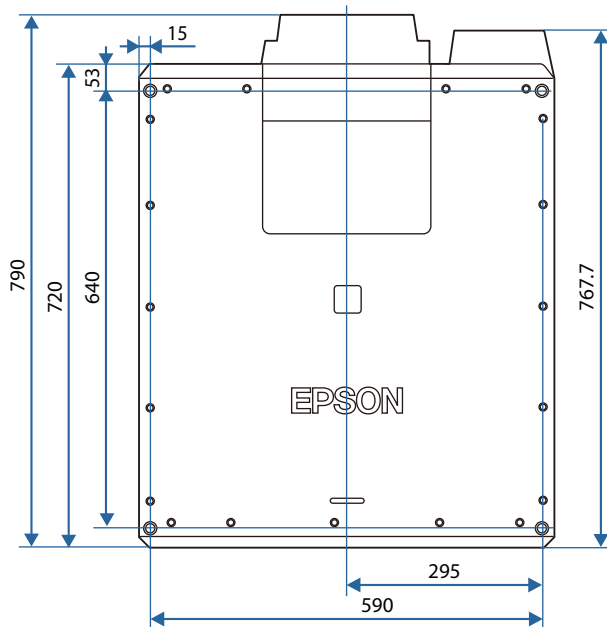
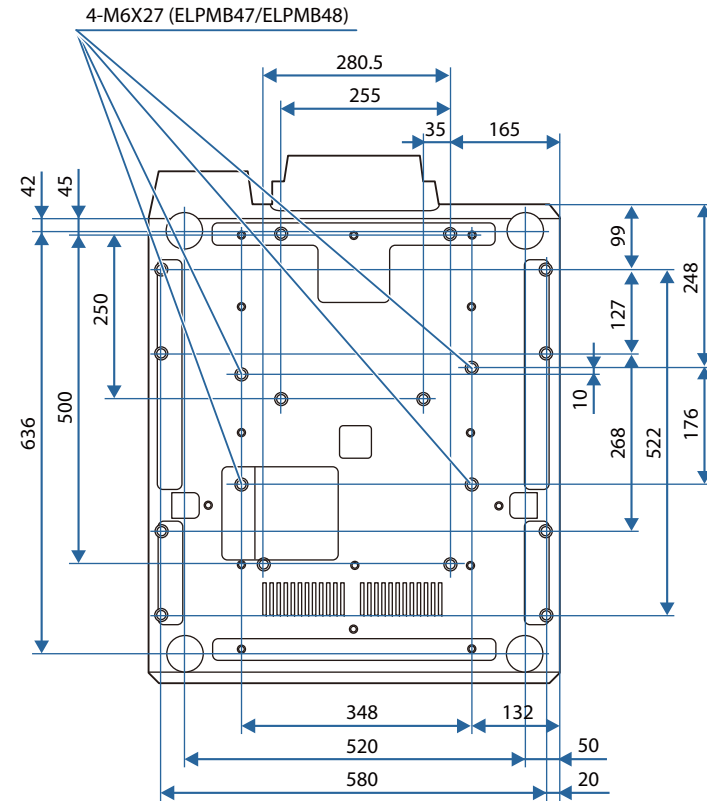

Units: mm

All rights reserved. No part of this publication may be reproduced, stored in a retrieval system, or transmitted in any form or by any means, electronic, mechanical, photocopying, recording, or otherwise, without the prior written permission of Seiko Epson Corporation. No patent liability is assumed with respect to the use of the information contained herein. Neither is any liability assumed for damages resulting from the use of the information contained herein.

Neither Seiko Epson Corporation nor its affiliates shall be liable to the purchaser of this product or third parties for damages, losses, costs, or expenses incurred by the purchaser or third parties as a result of: accident, misuse, or abuse of this product or unauthorized modifications, repairs, or alterations to this product, or (excluding the U.S.) failure to strictly comply with Seiko Epson Corporation's operating and maintenance instructions.

Seiko Epson Corporation shall not be liable against any damages or problems arising from the use of any options or any consumable products other than those designated as Original Epson Products or Epson Approved Products by Seiko Epson Corporation.

The contents of this guide may be changed or updated without further notice.

Illustrations in this guide and the actual projector may differ.

Restriction of Use

When this product is used for applications requiring high reliability/safety such as transportation devices related to aviation, rail, marine, automotive etc.; disaster prevention devices; various safety devices etc; or functional/precision devices etc, you should use this product only after giving consideration to including fail-safes and redundancies into your design to maintain safety and total system reliability. Because this product was not intended for use in applications requiring extremely high reliability/safety such as aerospace equipment, main communication equipment, nuclear power control equipment, or medical equipment related to direct medical care etc, please make your own judgment on this product's suitability after a full evaluation.

About Notations

Microsoft® Windows Vista® operating system
Microsoft® Windows® 7 operating system
Microsoft® Windows® 8 operating system
Microsoft® Windows® 8.1 operating system
Microsoft® Windows® 10 operating system

In this guide, the operating systems above are referred to as "Windows Vista", "Windows 7", "Windows 8", "Windows 8.1", and "Windows 10". Furthermore, these may be referred to as the collective term Windows, and multiple versions of Windows may be referred to as, for example, Windows Vista/7/8/8.1/10, with the Windows notation omitted.

OS X 10.7.x
OS X 10.8.x
OS X 10.9.x
OS X 10.10.x
OS X 10.11.x
macOS 10.12.x

In this guide, the operating systems above are referred to as "OS X 10.7.x", "OS X 10.8.x", "OS X 10.9.x", "OS X 10.10.x", "OS X 10.11.x", and "macOS 10.12.x". Furthermore, the collective term "Mac" is used to refer to them all.

Trademarks and Copyrights

"EPSON" is a registered trademark of Seiko Epson Corporation. "EXCEED YOUR VISION" is a trademark or registered trademark of Seiko Epson Corporation.

Mac, Mac OS, OS X, and iOS are trademarks of Apple Inc.

Microsoft, Windows, Windows Server, Microsoft Edge, Windows Media, and the Windows logo are trademarks or registered trademarks of Microsoft Corporation in the United States and/or other countries.

App Store is a service mark of Apple Inc.

Android, Chrome, Chromebook, and Google Play are trademarks of Google LLC.

HDMI and High-Definition Multimedia Interface are the trademarks or registered trademarks of HDMI Licensing LLC. 

PJLink trademark is a trademark applied for registration or is already registered in Japan, the United States of America and other countries and areas.

WPA™ and WPA2™ are registered trademarks of the Wi-Fi Alliance.

"QR Code" is a registered trademark of DENSO WAVE INCORPORATED.

Crestron, Crestron Connected, Crestron RoomView, and Crestron Fusion are registered trademarks of Crestron Electronics, Inc.

etherCON® is a registered trademark of Neutrik AG.

Art-Net™ Designed by and Copyright Artistic Licence Holdings Ltd.

Extron® and XTP® are registered trademarks of Extron Electronics.

HDBaseT™ and the HDBaseT Alliance logo are trademarks of the HDBaseT Alliance.

The DisplayPort Certified Logo and DisplayPort Icons are Registered Trademarks of the Video Electronics Standards Association (VESA).

The word DisplayPort is a Registered Trademark of VESA in various countries around the world.

Other product names used herein are also for identification purposes only and may be trademarks of their respective owners. Epson disclaims any and all rights in those marks.

©SEIKO EPSON CORPORATION 2019. All rights reserved.

Indication of the manufacturer and the importer in accordance with requirements of EU directive

Manufacturer: SEIKO EPSON CORPORATION

Address: 3-5, Owa 3-chome, Suwa-shi, Nagano-ken 392-8502 Japan

Telephone: 81-266-52-3131

<http://www.epson.com/>









Importer: EPSON EUROPE B.V.









Address: Atlas Arena, Asia Building, Hoogoorddreef 5,1101 BA Amsterdam
Zuidoost The Netherlands











Telephone: 31-20-314-5000

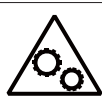

<http://www.epson.com/europe.html>

The following table lists the meaning of the safety symbols labeled on the equipment.

No.	Symbol mark	Approved standards	Meaning
①		IEC60417 No. 5007	"ON" (power) To indicate connection to the mains.
②		IEC60417 No. 5008	"OFF" (power) To indicate disconnection from the mains.
③		IEC60417 No. 5009	Stand-by To identify the switch or switch position by means of which part of the equipment is switched on in order to bring it into the stand-by condition.
④		ISO7000 No. 0434B IEC3864-B3.1	Caution To identify general caution when using the product.
⑤		IEC60417 No. 5041	Caution, hot surface To indicate that the marked item can be hot and should not be touched without taking care.
⑥		IEC60417 No. 6042 ISO3864-B3.6	Caution, risk of electric shock To identify equipment that has risk of electric shock.
⑦		IEC60417 No. 5957	For indoor use only To identify electrical equipment designed primarily for indoor use.
⑧		IEC60417 No. 5926	Polarity of d.c. power connector To identify the positive and negative connections (the polarity) on a piece of equipment to which a d.c. power supply may be connected.
⑨		---	The same as No. 8

No.	Symbol mark	Approved standards	Meaning
⑩		IEC60417 No. 5001B	Battery, general On battery powered equipment. To identify a device for instance a cover for the battery compartment, or the connector terminals.
⑪		IEC60417 No. 5002	Positioning of cell To identify the battery holder itself and to identify the positioning of the cell(s) inside the battery holder.
⑫		---	The same as No. 11
⑬		IEC60417 No. 5019	Protective earth To identify any terminal which is intended for connection to an external conductor for protection against electric shock in case of a fault, or the terminal of a protective earth electrode.
⑭		IEC60417 No. 5017	Earth To identify an earth (ground) terminal in cases where symbol No. 13 is not explicitly required.
⑮		IEC60417 No. 5032	Alternating current To indicate on the rating plate that the equipment is suitable for alternating current only; to identify relevant terminals.
⑯		IEC60417 No. 5031	Direct current To indicate on the rating plate that the equipment is suitable for direct current only; to identify relevant terminals.
⑰		IEC60417 No. 5172	Class II equipment To identify equipment meeting the safety requirements specified for Class II equipment according to IEC 61140.

No.	Symbol mark	Approved standards	Meaning
18		ISO 3864	General prohibition To identify actions or operations that are prohibited.
19		ISO 3864	Contact prohibition To indicate injury that could occur due to touching a specific part of the equipment.
20		---	Never look into the projection lens while the projector is on.
21		---	To indicate that the marked item don't place anything on projector.
22		ISO3864 IEC60825-1	Caution, laser radiation To indicate the equipment has a laser radiation part.
23		ISO 3864	Disassembly prohibition To indicate a risk of injury, such as electric shock, if the equipment is disassembled.
24		IEC60417 No. 5266	Standby, partial standby To indicate that part of the equipment is in the ready status.
25		ISO3864 IEC60417 No. 5057	Caution, movable parts To indicate that you must keep away from movable parts according to protection standards.
26		IEC 60417-6056	Caution (Moving Fan Blades) As a safety precaution, stay away from the moving fan blades.
27		IEC 60417-6043	Caution (Sharp Corners) To indicate sharp corners that should not be touched.
28		---	To indicate that looking into the lens while projecting is prohibited.

No.	Symbol mark	Approved standards	Meaning
29		ISO7010 No. W027 ISO3864	Warning, light emission (UV, visible light, IR, etc.) When you are close to the light emissions, be careful not to injure your eyes or skin.
30		IEC60417 No. 5109	Usage prohibition in residential areas To indicate that this is an electrical device or a device that is not suitable for use in residential areas.

- A**
- A/V settings 145
 - Air exhaust vent 19
 - Air filter notice 143
 - Air filter replacement period 208
 - AMX Device Discovery 157
 - Art-Net 157, 230
 - Aspect 80, 139
 - Auto 23
 - Auto setup 139
- B**
- Basic menu 150
 - Batch setup function 161
 - Beep 145
 - Black level 147
 - Brightness 137
 - BT.709 76
- C**
- Ceiling mount 144
 - Ceiling mount fixing points 23
 - Change input 23
 - Cinema 76
 - Cleaning 204
 - Cleaning the air filter and air intake vent 204
 - Cleaning the projector 204
 - Color adjustment 138
 - Color Mode 76, 137
 - Color saturation 137
 - Color Uniformity 143, 147
- D**
- Computer In 20
 - Computer Out 20
 - Configuration menu 132
 - Consumables 236
 - Contrast 137
 - Control panel 23
 - Corner wall 71
 - Crestron Connected 225
- E**
- Edge Blending 90, 147
 - EDID 140
 - Epson Web Control 214
 - Esc 24
 - ESC/VP21 223
 - Event ID 159
 - Extended menu 143
 - Extron XTP 146
- F**
- Feet 22
 - Filter indicator 171
 - Focus 24
- G**
- Gateway Address 153, 155
 - Geometry 24
 - Geometry correction 142
- H**
- HDBaseT 146
 - HDBaseT port 20
 - HDBaseT signal quality 159
 - Help function 170
 - High altitude mode 144
- I**
- Image adjustment menu 137
 - Indicator 171
 - Info menu 158
 - Input signal 158
 - Installation requirements 35
 - Installation settings 35
 - IP address 153, 155
- K**
- Keystone distortion 142
- L**
- Language 148
 - Lens operation lock 114
 - Lens replacement cover 32

- Lens Shift 24, 38
- M**
- Mail notification 156, 222
- Memory 143
- Menu 24, 132
- Message broadcasting 157
- Messages 143
- Multi-Projection 76, 147
- Multi-Projection function 86
- N**
- Natural 76
- Network configuration 149
- Network information 149
- Network menu 148
- Notification email address 1/2/3 156
- O**
- Operating temperature 249
- Operation 144
- Optional accessories 236
- Overheating 173
- Overscan 139
- P**
- Panel alignment 143
- Part names and functions 18
- Password protect 111
- PJLink 225
- PJLink password 150
- Port number 156
- Position 139
- Power inlet 19
- Power on protection 111
- Presentation 76
- Priority gateway 157
- Projection 144
- Projection distance 237
- Projection lens 31
- Projector 59, 61
- Projector ID 47
- Projector Keyword 151
- Projector name 150
- Q**
- Quick Corner 142
- R**
- Reading mail 222
- Rear 144
- Refresh Rate 158
- Remote control 25
- Remote control button lock 114
- Remote control ID 47
- Remote port 20
- Remote receiver 18, 19
- Replacing batteries 27
- Replacing the air filter 208
- Reset all config 160
- Reset memory 159
- Reset menu 159
- Resolution 139, 158
- Resolutions 246
- RoomView 226
- RS-232C port 20
- S**
- Scale 140, 147
- Schedule 107
- Schedule settings 147
- Screen settings 36, 143
- Screen Size 237
- Screen size 101
- Search access point 154
- Serial number 158
- Settings menu 141
- Sharpness 137
- Shutter 24, 102
- Signal menu 138
- Slot 20
- SMTP server 156
- SNMP 223
- Soft keyboard 150
- Source 100, 158
- Specifications 249
- Split screen 142
- Split Screen Setup 100
- Standby mode 145
- Startup screen 143
- Status 158
- Status indicators 18
- Status monitor 178
- Storage temperature 249
- Subnet mask 153, 155
- Supported Monitor Displays 246
- Swap screens 101
- Sync info 158



Sync. 139

T

Test Pattern 24, 143

Test pattern 37

Tint 137

Tracking 139

Trap IP address 1/2 156

U

User Button 142

User's Logo 103

User's logo protection 111

W

Web browser 214

Web control password 151

White Balance 137

Wired LAN menu 155

Wireless LAN menu 151

Z

Zoom 24